

SENSICK Technology

A

Absolute encoders, linear

Linear position measuring systems for material handling applications e.g. storage and conveying systems, have particularly high requirements. The current position is continuously evaluated by the sensor unit and is directly transmitted as an encoded signal by the evaluation electronics housed in the sensor unit. Since the sensor unit and the reference scale are separate components, even extremely long distances can be measured.

Absolute encoders, rotary

Absolute encoders generate information relating to position, angle or number of revolutions in the form of unique codes. A unique code is assigned to each angular step. The number of unique code patterns per revolution determines the resolving capability. Since an absolute position is assigned to each unique code pattern, an initialising reference run is not required. Singleturn and multi-turn versions are available.

Alignment aid

Optical and electronic alignment aids are used to facilitate the alignment of sensors with receiver elements, reflectors or objects to be scanned.

This is particularly important if the emitted light beam is difficult to see or invisible, and if sensors are expected to cover large distances (sometimes up to several hundred metres). An alignment sight is the simplest optical alignment aid. It can be used for rough alignment. Optical indicators on the device usually assist the fine adjustment of a sensor.

Alignment accuracy is indicated by LEDs lighting up, flashing and going out or, in some cases, by a red/green LED changing colour.

The visible red light used in many sensors is an additional alignment aid. When the sensor

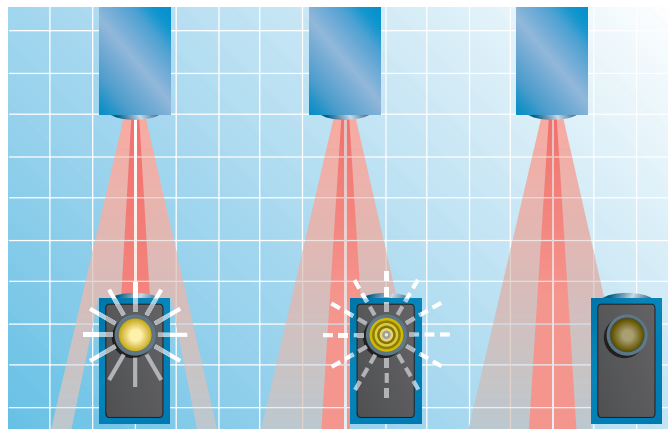

▲ An indicator that is permanently lit shows correct adjustment. Small adjustments are indicated by a flashing light while complete misalignment extinguishes the light.

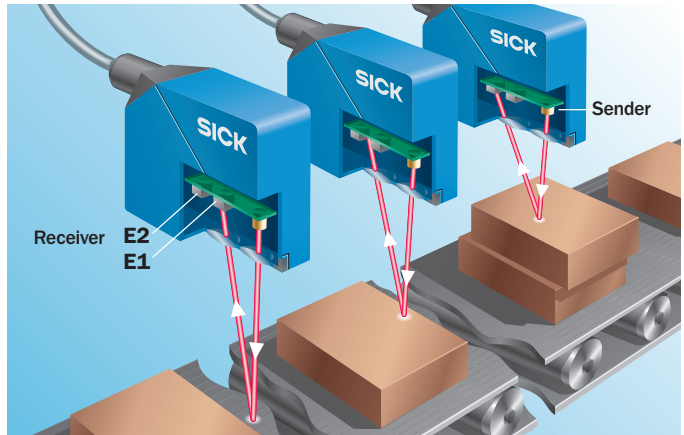

▲ Operating principle behind background suppression BGS

is being aligned with a reflector or object to be detected, the red light is clearly visible as a light spot.

To cope with scanning ranges of over 100 metres, a number of photoelectric switches have special alignment optics which permit relatively precise alignment over such large distances.

B

Background suppression BGS

Photoelectric proximity switches detect an object using its reflective behaviour. With energetic switches this means: Light surface – large scanning distance. Dark objects – smaller scanning distance.

These devices soon reach their limitations if they have to detect dark objects on a light background since the light emitted from the plane behind the object “dazzles” the energetic sensor. Photoelectric proximity switches with background suppression are the ideal solution in such cases. The devices function according to the “glare-free” triangulation principle and have two separate receiver elements which are used to

▼ Bus systems: Linking sensors and actuators with AS-i

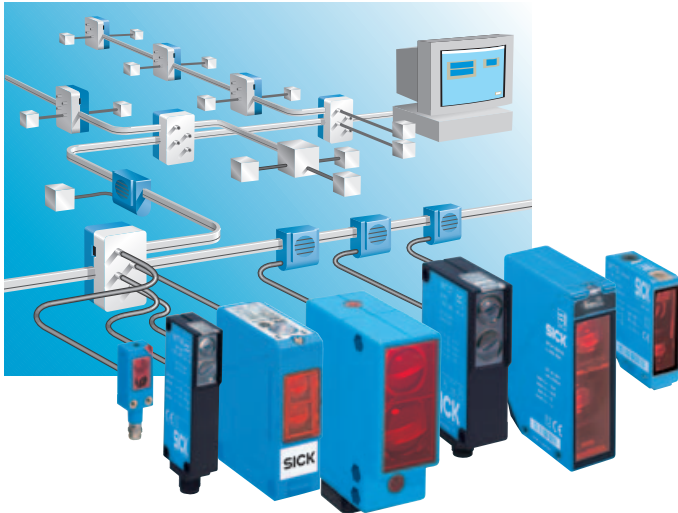

detect the reflectivity of an object.

How background suppression functions:

The light spot of the BGS photoelectric proximity switch is used to align the device with the object so that the reflection is detected only by receiver E2. Anything lying behind this focal plane is blanked out. The maximum distance between the object surface and background plane basically depends on the reflectivity of the object to be detected (see illustration). If the object leaves the sensor's detection range, the angle of reflection changes. The reflected light beam is then detected by receiver E1 and electronically suppressed. No false switching occurs.

Bus systems

In complex production processes, the total cost of sensors and actuators does not depend on the purchase price alone. Installation costs also play a decisive role. These costs can be reduced considerably if decentralised automation systems with bus technology are used. Universal field bus terminals and couplers enable SICK sensors to be rapidly integrated into all standard systems, e.g.:

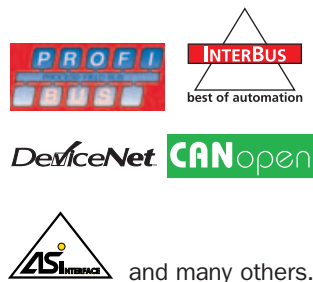

and many others.

Photoelectric proximity switches, photoelectric reflex switches, through-beam photoelectric switches, colour sensors, contrast and luminescence scanners, distance measuring devices and barcode reading systems can all be interconnected.

The Safety Bus P+, a bus solution allowing bidirectional communication between safety systems and the control units of machines, is available for safety engineering applications.

While bus systems like Profibus-DP, Interbus, DeviceNet and CANopen cater for the upper field level in automation structures, AS-i (Actuator Sensor Interface) is the ideal wiring technology for the lowest field level in decentralised control concepts.

This technology can be used instead of complex parallel wiring to interconnect a large number of different sensors and actuators simply, quickly and at low cost. The AS-i bus can easily be integrated into a higher-level control unit e.g. a PLC or computer. All AS-i-compatible sensors, e.g. SICK photoelectric switches and photoelectric proximity switches, contain an application-specific circuit, the AS-i chip. To ensure that standard components can also be incorporated, this module is also integrated in an external AS-i module that has its own address and can serve four

conventional sensors or actuators.

C

Cables

- PUR cable
 - oil-resistant cable
 - not resistant to hydrolysis
- PVC cable
 - not suitable for continuous use in environments containing oil
 - not ozone- or UV-resistant
- PUR-PVC cable
 - PVC cable coated with PUR

The cables must not be moved in temperatures below -5 °C otherwise they may rupture.

Capacitive proximity sensors

Capacitive proximity sensors detect metallic and non-metallic objects. The higher the relative permittivity of the object to be detected, the greater the sensing range. Among the applications for which they are used are:

- level monitoring
- level control of bulk goods
- final inspection in packaging processes

SENSICK Technology

Color recognition

Color sensors can recognise objects by their colour using both incident light and transmitted light – e.g. with transparent objects or liquids. Depending on the task in question, one or three reference colors can be taught and stored. Since color sensors are extremely insensitive to ambient light, the level of recognition reliability is not affected by reflections or light entering at the side of the sensor.

Color sensors

CS color sensors function using a special three-color method. They cast light (red, blue, green) on the objects to be tested, calculate the chromaticity co-ordinates from the reflected radiation and compare them with previously stored reference tristimulus values. If the tristimulus values are within the set tolerance range, a switching output is activated. SICK color sensors can detect both the colors of opaque objects through their reflections (incident light) and those of transparent materials in transmitted light, whereby a reflector is mounted opposite the sensor.

▼ Color sensor

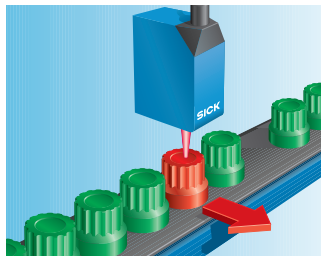

Conformity

Consumer and capital goods introduced onto the European single market must conform to specific directives. Essentially, SENSICK optoelectronic sensors are subject to two laws:

- EMC directive 89/336/EEC and low-voltage directive 73/23/EEC.
- SICK, as the product manufacturer, declares compliance with the requirements specified in these directives by attaching the CE symbol to its products.

 In the USA, the operation of electrical systems is subject to national regulations and is monitored by the OSHA (Occupational Safety and Health Act) and the NEC (National Electrical Code). Testing is conducted by the Underwriters Laboratories, which also issue the necessary identification labels. The “R” stands for “recognized” and means that the sensor has a component licence. When a device is used, the conditions for

approval must be observed and complied with.

 Devices with an individual licence and an approval number issued by the Underwriters Laboratories bear the letter “L” for “listed” in the signet.

This identification mark permits the authorities to conduct an unannounced inspection of serial products at any time.

 In Canada, the operating regulations for electrical systems and components are subject to the Canadian Electrical Code (CEC).

It prescribes CSA conformity for all devices. The appropriate identification symbol is issued if the device passes an individual inspection conducted by the Canadian Standard Association.

 As an alternative, UL today offers combined approval for both the USA and Canada.

 If there is a possibility of an explosive atmosphere being formed, the electrical equipment intended for use in such areas must be designed and labelled accordingly, and certified by an independent testing authority, e.g. the Federal Physical-Technical Office in Braunschweig, Germany.

Contamination control

Photoelectric switches and photoelectric proximity switches operate if the received light signal is well above a programmed switching threshold.

With time, deposits caused by mist, dust, dirt, splash-water, cleaning work in the system, etc. accumulate on the device’s optical components and reflectors. As a result, the level of the received light drops and approaches the set switching threshold. If the light level falls below the switching threshold, the device can no longer detect objects.

In order to give sufficient early warning to the user of imminent failure due to contamination, the majority of SENSICK devices have a pre-failure warning function. If the intensity of the received light is less than 50 % above the switching threshold, the receiver lamp begins to flash. A number of devices also have a signalling output which functions independently of the switching outputs and is used to monitor the contamination.

▼ Although the switching output continues to exhibit a defined switching characteristic, the flashing LED signals that the intensity of the receiver light has dropped below the safety limit of less than 1.5 times the operating reserve.

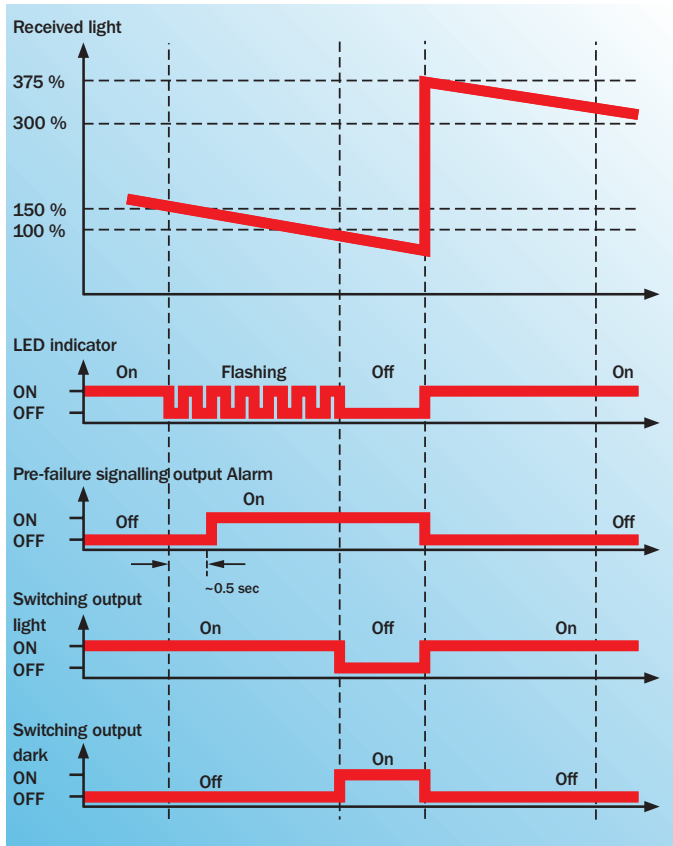

Contrast scanners

Contrast scanners function energetically according to the principle of photoelectric

▼ Contrast scanners

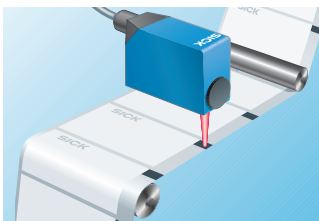

proximity switches. At a constant scanning distance, up to 30 grey tones from a scale ranging from black to white can be distinguished. This property is essential for detecting contrast marks, for example printed colour bars. The difference in contrast between the mark and background is the main factor determining the readability of a mark. The surface of the material can be coarse,

smooth or glossy, and can be made of paper, plastic or metal.

When glossy materials are to be detected the sensor should, if necessary, be tilted.

the device units are either installed in a fixed station and a mobile station (variable link) or both are installed in a separate fixed station (fixed link).

Detection of transparent objects

D

Data transmission-systems

SICK data transmission-systems together with infrared light can be used to form cable-free transmission links for serial data in full-duplex mode – this does away with trailing cables.

A link always consists of one device pair (2 device units) with different carrier frequencies.

Depending on the configuration of the transmission link,

Transparent objects such as clear foil, cellophane, transparent labelling film, glass bottles and filled PET mineral water bottles were once the most difficult objects to detect in packaging and filling systems.

In addition, the steady contamination of the sensors caused by leaked products, dust, mist or splash-water also had a major detrimental effect on the reliability of detection because the reflector signal, attenuated by the dirt deposits, increasingly

▼ Distance measurement and cable-free data transmission

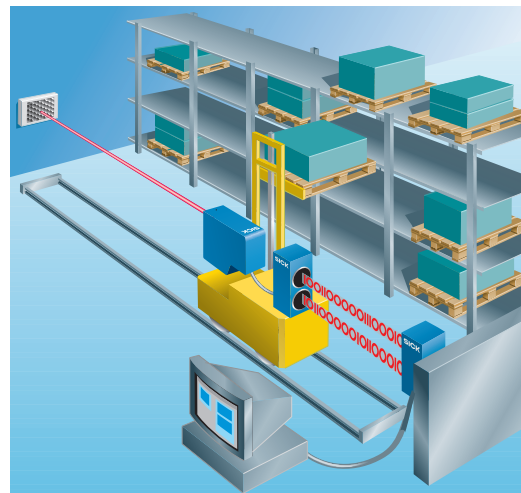

SENSICK Technology

▼ Application of operating voltage

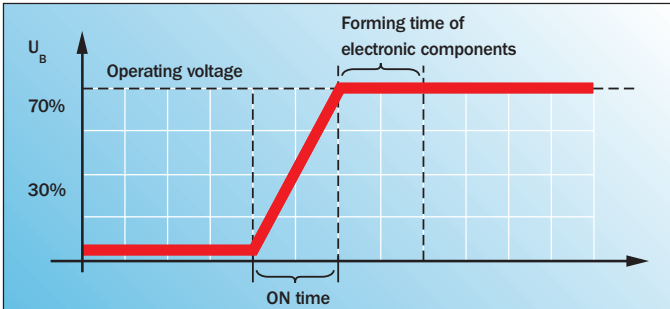

▼ Device without function to prevent false triggering at start-up. Switching output Q; possibility of incorrect signal behaviour

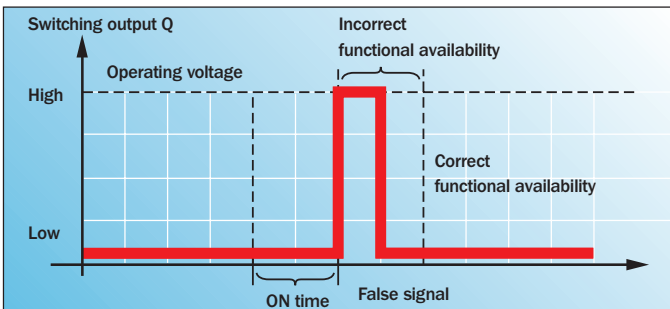

▼ Device with function to prevent false triggering at start-up. Switching output Q with safe signal behaviour

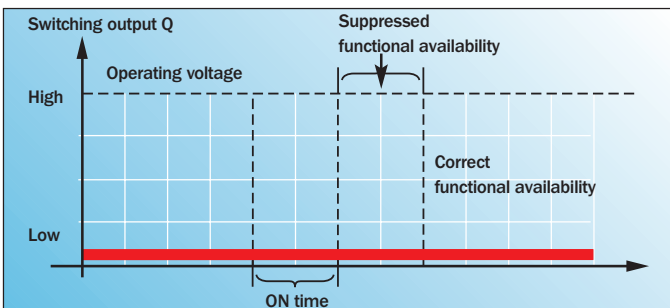

approximated the switching threshold which often very quickly led to sensor failure. In contrast, the “glass detection method” provides an extremely high degree of detection and switching reliability.

This method basically involves maintaining the difference in level between the reflector and switching signal. The switching threshold is adjusted to the unbroken light beam between the sensor



★ Switching at signal attenuation > 10 % – typical for clean, water-filled PET bottles.

★ Switching at signal attenuation > 18 % – characteristic for clear glass bottles and films.

★ Switching at signal attenuation > 40 % – as is the case with coloured glass or non-transparent objects.

and reflector. Various operating modes can be selected depending on the anticipated signal attenuation:

The switching threshold is evaluated by a microprocessor and continually adapted to any contamination – whereby the difference between the reflector signal and switching threshold is maintained electronically. There is, therefore, no dilution of the difference between the reflector signal (weakened by contamination) and the previously taught-in switching threshold, thus preventing detection problems.

Consequently, the device only requires maintenance in the case of severe contamination resulting in the system limit of the glass sensor being reached. This is considerably later than with conventional

sensors. After cleaning, the original signal level and threshold value are automatically restored.

Distance measurement

Distance sensors are used for the precise detection of distances or values deduced from these distances, e.g. a filling level or a position.

▼ DME 3000 positioning a high-bay stacker



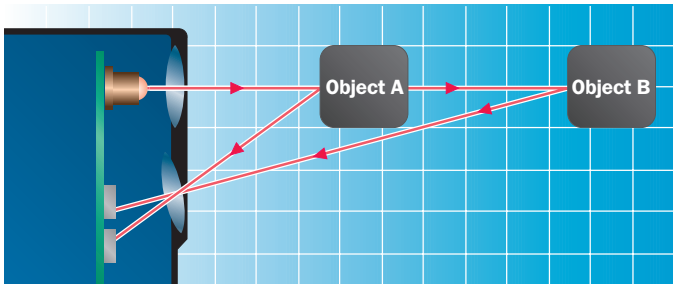

▲ Optical three-point method of distance measurement

The required ranging distance and accuracy are key factors when selecting the system which is technically and economically most suitable for the application in question.

Distance sensors reflector mode and proximity mode

A distinction is made between two groups of distance sensors according to the measurement principle applied: The first group uses time-of-flight measurement of laser light.

In proximity mode, these devices can detect minute objects with difficult surface characteristics at great distances, even in front of a shiny background.

In the case of large measuring ranges, e.g. when determining the position of rail-mounted vehicles, they measure the distance to a reflector. In this way, distances of up to 500 m can be determined.

The second group uses laser light, redlight or infrared light in conjunction with the triangulation measurement method. The user-friendly “Teach-in” function is used to adjust and calibrate the sensors. Sensors, which can function as both scanners and measuring devices, can detect minute

▼ Distance sensor: component detection

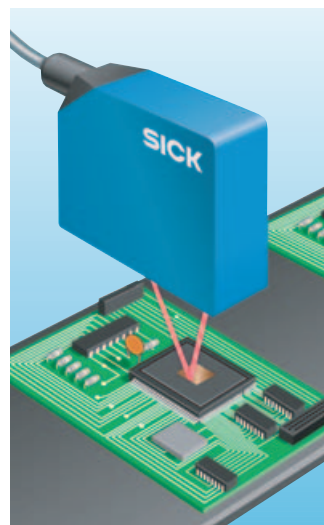

objects, indentations or unevenness – even in the μm range.

▼ Distance sensor: slack regulation

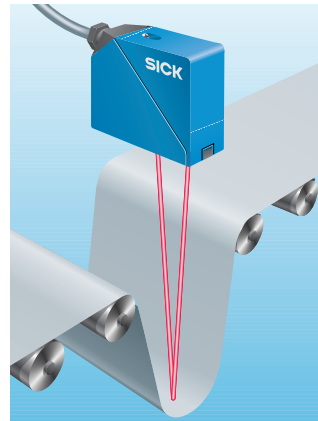

▼ Distance sensor: height control



SENSICK Technology

▼ Enclosure ratings

2nd digit:
Protection against ingress of water

1st digit:
Protection against ingress of foreign bodies

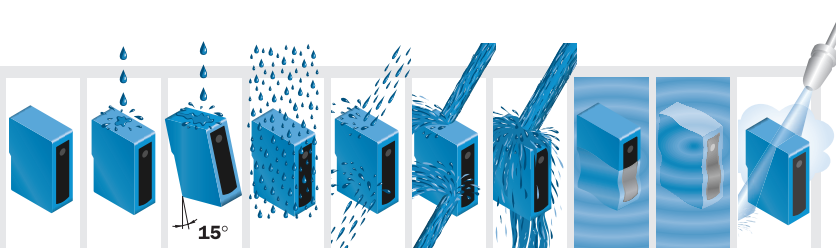

IEC 529 DIN 40050

No protection	Drip-water vertical	Drip-water tilted	Spray water	Splash water	Jet water	Strong jet of water	Temporary immersion	Lasting immersion	100 bar, 16 l/min., 80 °C
IP...0	IP...1	IP...2	IP...3	IP...4	IP...5	IP...6	IP...7	IP...8	IP...9K

IP 0...
No protection



IP 00									
-------	--	--	--	--	--	--	--	--	--

IP 1...
Size of foreign body ≥ 50 mm ø

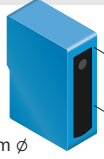

IP 10	IP 11	IP 12							
-------	-------	-------	--	--	--	--	--	--	--

IP 2...
Size of foreign body ≥ 12 mm ø



IP 20	IP 21	IP 22	IP 23						
-------	-------	-------	-------	--	--	--	--	--	--

IP 3...
Size of foreign body ≥ 2.5 mm ø



IP 30	IP 31	IP 32	IP 33	IP 34					
-------	-------	-------	-------	-------	--	--	--	--	--

IP 4...
Size of foreign body ≥ 1 mm ø



IP 40	IP 41	IP 42	IP 43	IP 44					
-------	-------	-------	-------	-------	--	--	--	--	--

IP 5...
Dust-protected



IP 50			IP 53	IP 54	IP 55	IP 56			
-------	--	--	-------	-------	-------	-------	--	--	--

IP 6...
Dust-proof



IP 60					IP 65	IP 66	IP 67		IP 69K
-------	--	--	--	--	-------	-------	-------	--	--------

E

EMC

Electromagnetic compatibility

Enclosure ratings

Enclosure ratings indicate the extent to which a machine or sensor is protected against direct contact and the ingress of foreign bodies and water. The code identifying the enclosure rating begins with the letters IP followed by the first digit which indicates the protection provided against direct contact and foreign bodies.

The second digit describes the protection provided against the ingress of water. The higher the number, the greater the respective type of protection. Enclosure ratings of IP 65 and higher have become standard in industrial environments. The majority of SICK sensors are IP 67.

F

Foreground suppression FGS

Foreground suppression enables triangulation photoelectric proximity switches to be used to reliably detect objects of any height and with any surface characteristics.

Foreground suppression is ideal for applications where surfaces exhibit major differences in reflectivity, flat objects are to be detected on conveyor belts, or the object has a complex structure or a glossy surface.

How foreground suppression functions:

The visible light spot of the photoelectric proximity switch is aligned with the background (e.g. a conveyor belt) so that the reflectivity of this focal plane is detected by receiver E1 only.

In this case, the electronics complete the circuit and a signal is applied at the switching output. If, however, an object passes through the area between the focal plane and the sensor, the angle of reflection changes.

The reflected light beam is now detected by receiver E2. The previously lit receiver lamp goes out, the switching signal is no longer supplied – the object has been detected.

▼ Operating principle behind foreground suppression

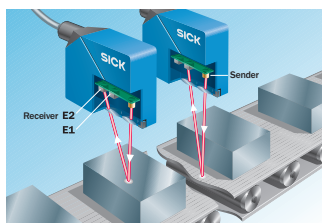

▼ Fork sensor

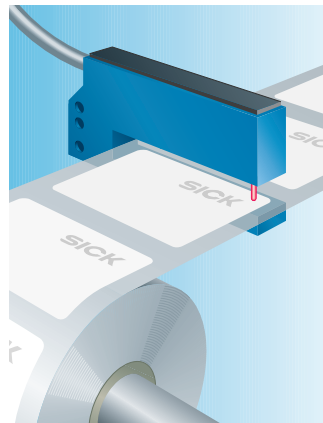

Fork sensors

These sensors, which function as two-unit through-beam systems, combine a sender and receiver in a single housing. The distance between the sender and receiver is determined by the shape of the housing and is referred to as the fork width. The emitted light, in the form of a precisely concentrated beam, and the high detection accuracy mean that even minute differences in light attenuation can be detected.

G

Geometry of emitted light

Depending on the task to be fulfilled by an optoelectronic sensor and its emitted light source, a distinction is made

▼ Divergent emitted light: through-beam photoelectric switches and photoelectric reflex switches

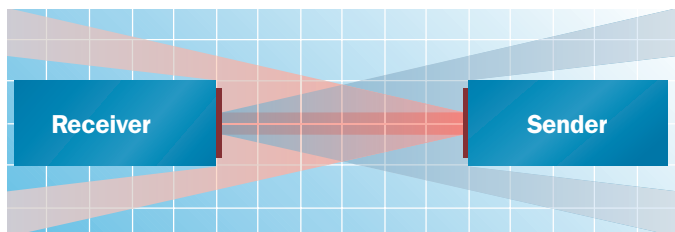

▼ Convergent, focused emitted light: photoelectric proximity switches

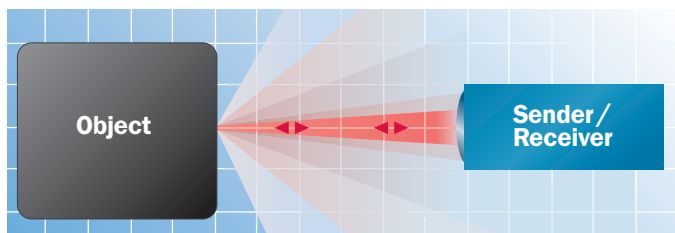

▼ Parallel emitted light: laser photoelectric proximity switches and laser photoelectric switches, distance sensors

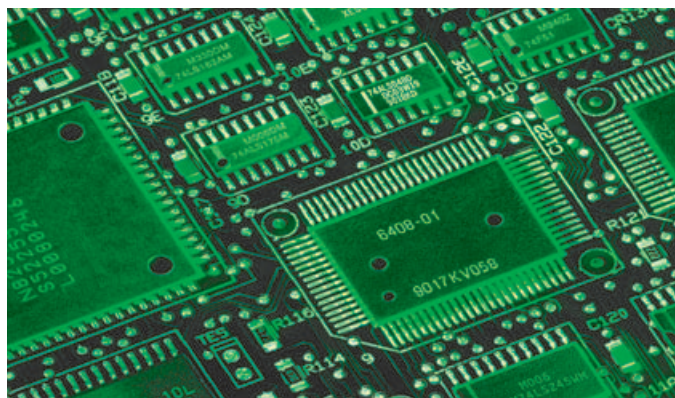
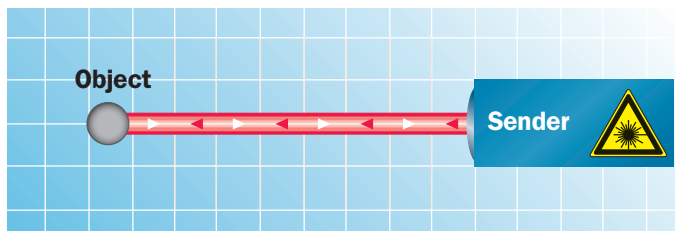

▲ Laser technology used to detect minute objects

between divergent, convergent and parallel emitted light.

Divergent emitted light is used in, for example, through-beam systems.

SENSICK Technology

Senders and receivers have similar emission and reception characteristics with respect to their dispersive beam.

The advantages: Simple alignment, insensitivity to fluctuations, vibration, and minor misalignments.

A particular advantage is the very accurate positioning of objects. The precision and detection of small components can be improved further by using slotted diaphragms.

Photoelectric reflex switches, which are aligned with reflectors, normally function using the same principle. The low resolution of the divergent emitted light may prove to be a problem in some cases.

The reduced cabling requirement is, however, one advantage of these switches.

Special photoelectric proximity switches are often used if small objects are to be detected in quick succession with a high level of accuracy. The beam path of the light that they emit is convergent and has a point of intersection (the "focal plane") at a certain distance.

The light spot is at its smallest at precisely this point which, in turn, means precise object detection at a high resolution.

These advantages can only be fully utilised if a number of conditions are satisfied, e.g. the switches are attached to vibration-resistant mounts

and the scanning distance remains constant.

Laser diodes can be used to produce a highly parallel light beam. Large scanning ranges are possible thanks to the low dispersion of this light source. The small light spot diameters produced on the objects are a further advantage of laser technology. This enables even minute objects to be detected.

H

Height detection

The height of objects can be detected in many different ways. Photoelectric proximity switches are able to provide simple binary responses, such as "Height OK" or "Height not OK". However, distance sensors with analogue output can be

used to supply continuous height information.

Special systems, or even cameras, are required as the complexity of the application in question increases.

The new DMH multifunction sensor from SICK offers a cost-effective solution in cases where CCD camera systems are "over-engineered" or simply too expensive. The sensor's sender projects a line of light at a defined angle across the object to be detected. If the line of light hits the surface of the object, its shape will change according to the profile of the object. Owing to the fixed angle between the sender and receiver axes, the line of light hitting an object is projected onto the receiver array as a contour corresponding to the height profile of the object. This technique permits height detection with millimetre precision.

The height profile sensor can be used to monitor height profiles, count magazines, monitor edges, detect filling levels, or check the presence of objects and detect their alignment.

Housing material

- Brass, nickel-plated
- Stainless steel
- Aluminium
- Plastic (PA12, PBT, PPE)

If the sensors are to be frequently or continuously exposed to chemicals, an application test must be performed. Contact SICK AG for further information.

Hysteresis H

The hysteresis is the positional difference between the activation and deactivation point for attenuating material as it is brought closer or moved away. It is required to ensure a smooth, stable switching action. It is given as a percentage of the real sensing range or in mm.

I

Incremental encoders, rotary

Incremental encoders generate information relating to position and angle in the form



▲ Tiles checked to ensure that they are correctly positioned

of electrical impulses. The number of pulses per revolution determines the resolving capability. The individual position is determined by counting these pulses from a point of reference. When the power is first switched on an initialising reference run is needed to determine absolute position.

Inductive proximity sensors

Millions of inductive proximity sensors have proven their reliability in virtually all sectors and branches of industry. They detect metallic objects and are suitable for a wide variety of applications on account of their various housing shapes and sizes. Applications include:

- Position polling
- Transport monitoring
- Counting pulse generation
- Speed monitoring
- Speed direction detection
- Feed and ejection control
- No-load and back-log monitoring

Insensitivity to ambient light

In order to detect objects, photoelectric switches and photoelectric proximity switches evaluate the light that they have emitted and its reflection from a reflector or

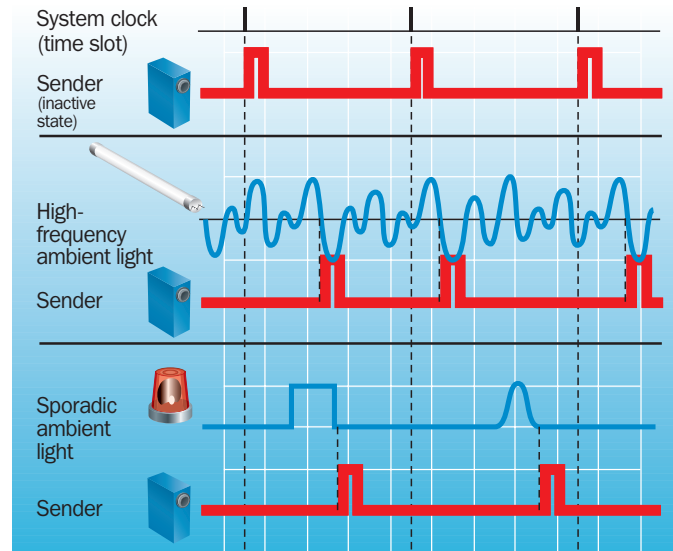

from the surface of an object to be detected. Simultaneously other light sources (from the sun to high-frequency radiation sources) also emit light referred to as ambient light. Ambient light must not be allowed to have a detrimental effect on the functioning of the opto-electronic devices, otherwise erroneous switching may occur. For this reason, one of the principal requirements of users is a high level of insensitivity to ambient light, especially from high-frequency or flashing warning lamps, without negatively affecting the performance characteristics of the optoelectronic sensors. The sender only emits a pulse during a defined time slot.

The receiver is only active and monitors the environment during this time slot. If the receiver does not detect any interference pulse, the emitted pulse is set to the end of the time slot and detection is then carried out. If periodic interference occurs, the intelligent electronics determine the best time for detection. In this interference-free zone, the optical sensor then only processes the light that has been emitted by itself.

SENSICK Technology

L

Laser classes

The table shows the laser classes EN 60825 and VDE 0837.

Detailed information concerning the precautions required for the laser classes can be found in the relevant sections of the standards.

Light section sensors

The light section sensor emits a line of laser light at a defined angle across the object to be scanned.

The laser line across the object is then projected onto a square receiver array as a silhouette corresponding to the height profile of the object.

In this way, it is possible to monitor height profiles, count

newspapers and magazines, detect filling levels or the position of objects, and check the presence of objects. Various integrated software variants make the DHM a fast and universal solution.

Luminescence detection

With luminescence detection, the electrons of a fluorescent substance are bombarded with UV light at a wavelength of between 365 and 385 nm (depending on the device). The visible light thus generated lies between approx. 420 nm and 750 nm of the spectral range. This light is then picked up by the luminescence scanner and used for detecting the object being scanned.

The sensitivity of the device can be set with a potentiometer to allow optimum adjustment to the fluorescence. The background to which the luminophores are applied does not affect the level of detection reliability. Luminophores can be mixed with virtually any substances, e.g. inks, oils, greases and adhesives.

Furthermore, they can also be applied to solid materials such as labels or cardboard boxes even if other information has already been printed on these materials. Since the markings can also be invisible, they are suitable for use as control marks on goods as proof of their authenticity, e.g. top-quality branded articles. And because they are invisible, the labels do not spoil the appearance of consumer goods.

▼ Summarising the laser classes

Description of danger class	Class 1	Class 2	Class 3A	Class 3B*)	Class 4	
Remotely controlled interlock	Integrated safety through constructional measures.		Low power; eyes normally protected by averting reflex.	As for Class 2. Looking directly into the beam using optical aids can be dangerous.	Looking directly into the beam using optical aids can be dangerous.	High power; even diffuse reflection can be dangerous.
Key-operated switch	Not required		Must be integrated in room or door circuits			
Beam attenuator	Not required		Remove key when not in use			
Beam indicator	Not required		Permanently mounted devices must be attached to attenuate or block the beam.			
Warning symbol	Not required		Must indicate when laser is in operation.			
Warning symbol	Not required		Information in warning symbols must be observed.			
Beam path limitation	Not required	Devices must terminate beam at end of its useful path.				
Specular reflection	No precautions required			Install devices so that inadvertent reflection is prevented.		
Eye protection	No requirements specified		Required if constructive and organisational precautions are not possible and maximum permissible exposure values are exceeded.			
Protective clothing	Not required		May be necessary in some cases.	In accordance with special requirements.		
Training	No requirements specified		Required for operating and service personnel.			

*) In the case of interlocks, key-operated switches, beam indicators and attenuators, Class 3B lasers which do not exceed the limit values of Class 2 by more than 5 times at wavelengths ranging from 400 nm to 700 nm are treated as Class 3A lasers.

▼ Light section sensor: edge detection

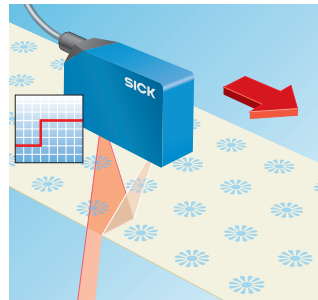

▼ Light section sensor: object detection

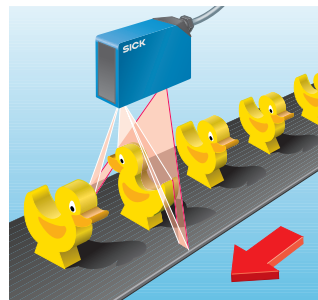

▼ Light section sensor: offset stack counting

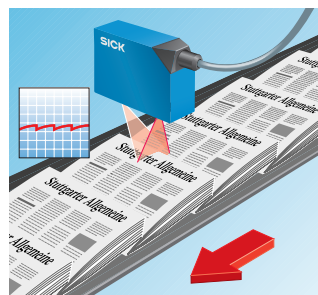

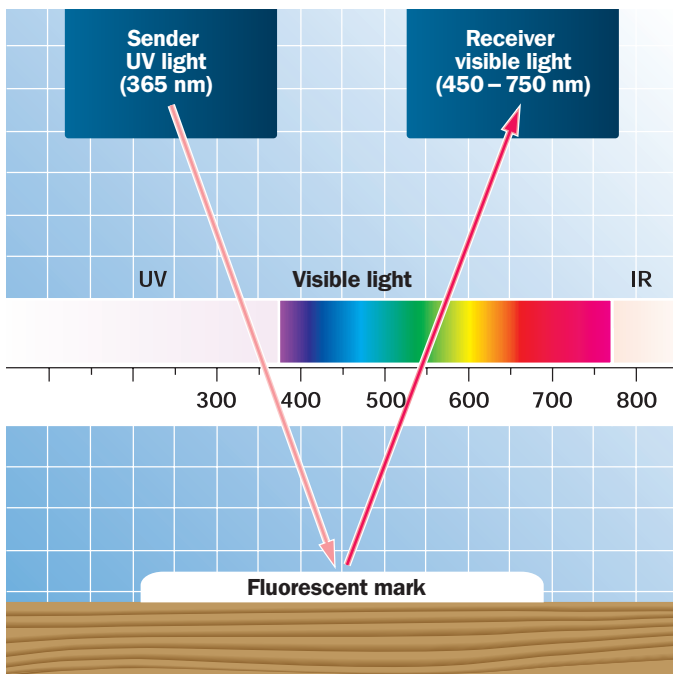

▲ UV light is converted into visible light by luminophores on the object being scanned.

Luminescence scanners

Luminescence scanners react to luminescent pigments which are activated by the UV light source in the scanner. The light, which is then reflected back, is received and evaluated by the luminescence scanner.

▼ Luminescence scanner

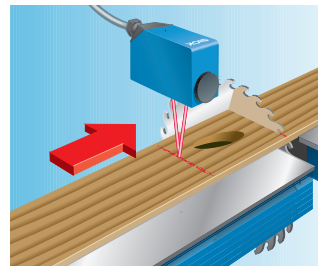

M

Machine Vision

The step to recognition of structures and objects is possible with Intelligent Camera Sensors (ICS).

The use of appropriate sensors opens up all three test dimensions. The same simple basic principles of “teach-in, comparison and assessment”, as for other sensors, lead to easy and reliable evaluation. Particularly reliable object detection through very uniform illumination and high intensity of light leads to high safety in production. Easy assembly through integration of lighting, image

reception, evaluation and output of results in an industry-compatible housing. Suitable for applications with high speed moving objects due to very fast image reception and image processing from 2.5 ms. Also easy to use and easily adaptable, since the sensor itself initially calculates its setting for the application. The user, however, is then able to specifically optimise all parameters. The representation of the camera image in the operating device’s display is a valuable alignment aid. The ICS devices with rotating contour comparison also detect rotated objects. The rotating contour comparison also reliably detects very small deformities in objects.

ICS variants with RS 232 interface allow the easy exchange of taught – in values and the management of any number of these values on a PC. In conjunction with the option of calibrating the integrated lighting at the click of a mouse, the user can create (copy) identical solutions

▼ ICS: Pixel amount comparison



▲ Using luminescence scanners to detect presence of labels in the pharmaceutical industry.



▲ Marks on planks are detected by luminescence scanners. Sawing is triggered.

SENSICK Technology

▼ ICS: Area comparison



▼ ICS: Shape comparison



▼ ICS: Minimum pixel amount



or – as with upgrades – exchange the sensor within a few minutes.

Color Vision Sensors (CVS) specialising in the detection and/or distinction of colored objects.

A colour display, few controls and a great depth of focus

assist the user in commissioning the sensor quickly and successfully. Retrospective parameter editing allows the CVS to be adjusted to a multitude of different applications.

Magnetic cylinder sensors

For many tasks in automation technology, it is necessary to detect the movement processes and positions of pneumatic cylinders accurately. In answer to this problem, SICK offers special magnetic cylinder sensors used to detect the position of pistons in pneumatic cylinders. They are attached directly to the cylinder body. They reliably detect a magnetic ring in the piston through the housing wall made of aluminium, brass, or stainless steel, and then trigger a switching signal. The magnetic cylinder sensors from SICK are characterized by high sensitivity and repeat accuracy as well as practical mounting technology for all current pneumatic cylinders.

Magnetic proximity sensors

Magnetic proximity sensors, even smaller models, are especially characterized by their large sensing ranges. They detect magnetic objects (usually permanent magnets)

which are used to trigger the switching process. Since these magnetic fields pass through many non-magnetizable materials, the switching process can also be triggered without the necessity for direct exposure to the objects to be detected. By using magnetic conductors (e.g. iron), the magnetic field can be transmitted over greater distances so that, for example, the signal can be carried away from an area with a high temperature. Magnetic sensors have a broad range of applications. For example:

- Object detection through plastic containers/ pipes
- Object detection in aggressive media through protective Teflon walls
- Object detection in high-temperature areas
- Detection of codes using magnets

P

Photoelectric proximity switches, background blanking BGB

Background blanking for photoelectric proximity switches is achieved either electronically or optically. In the optical method the angle between the sender and receiver light beam is altered while setting the scanning distance to the

object. Objects are detected at the point where the emitted beam is reflected back directly to the receiver element. Anything lying below this point is cut out as no light, or too little, reaches the receiver element. In the electronic method PSD elements (Position Sensitive Devices) are used. The emitted light beam is reflected by the object and hits the PSD receiver. Depending on the location of the impinging light beam, the incoming signal is recognised as being a background signal and electronically cut out.

▼ BGB – background blanking

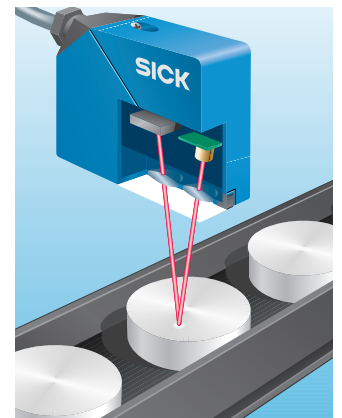

Photoelectric proximity switches, background suppression BGS

The operating principle of photoelectric proximity switches with background suppression is based on the geometrical relationship

▼ BGB – background suppression

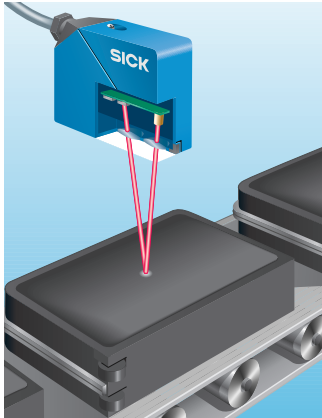

between the sender and receiver elements.

The switch is adjusted to the object located in the scanning plane. Signals from objects which are behind the set scanning plane are suppressed. Photoelectric proximity switches with background suppression can be negatively influenced by high-gloss objects in the background, e.g. glass panels, polished sheet metal and so on. If the background is not defined within the given sensor scanning distance, then these effects may increase. This problem can be solved by screening off or tilting the devices.

Photoelectric proximity switches, energetic

The least expensive solution is the energetic photoelectric proximity switch with adjustable sensitivity. A light surface reflects more light than a

dark surface and can, therefore, be detected from a greater distance. In order to achieve similar results with a dark surface, the sensitivity of the switch must be increased. The detection of a dark object in front of a light background is a problem for energetic switches. Owing to its higher reflection factor, the background “outshines” the object. The switches are, however, ideal for detecting a light object in front of a dark background.

▼ Photoelectric proximity switch

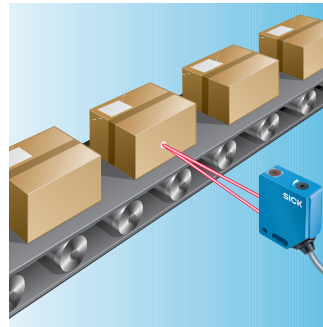

Photoelectric proximity switches for accumulating roller conveyors, background suppression BGB

These non-contact photoelectric proximity switches, which were specially developed for handling systems, detect the conveyed object from between the rollers. The detection signal is evaluated in the logic unit and the electro-pneumatic cylinder is actuated via the valve.

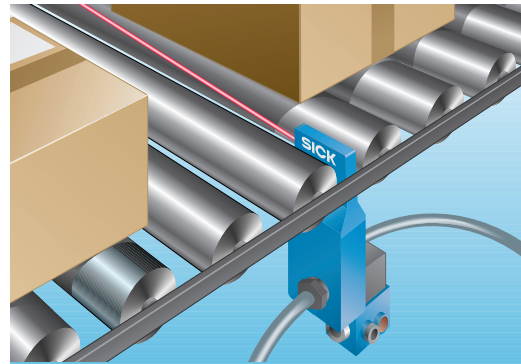

▲ Accumulating roller conveyors

Use of these switches automatically fulfils the principle of accumulating conveyor systems without the need for additional control elements.

Photoelectric proximity switches, foreground suppression FGS

Photoelectric proximity switches with foreground suppression are able to detect objects within a defined scanning distance. All objects between the scanning distance (set to the background) and the scanner

itself are detected above a minimum size. Suppression of the foreground is achieved by means of a special geometrical arrangement of sender and receiver elements. To ensure that these switches can function reliably, the background (e.g. a conveyor belt) must be relatively light in colour and its height must not fluctuate.

Photoelectric reflex switches

With the photoelectric reflex switches, the emitted light beam is reflected by a reflector and then received and evaluated by the device. Polarisation filters prevent incorrect operation when reflective objects are detected. Transparent films and shrink-wrap may influence the way in which the reflex photoelectric switches with polarisation filters function. Devices with reduced sensitivity solve this problem.

▼ FGS – foreground suppression

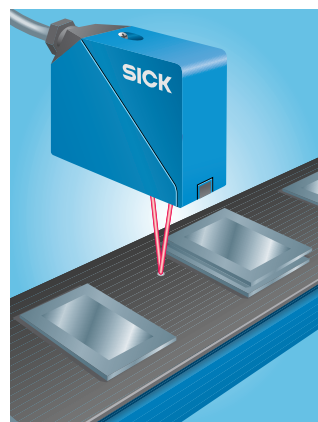

SENSICK Technology

▼ Photoelectric reflex switch

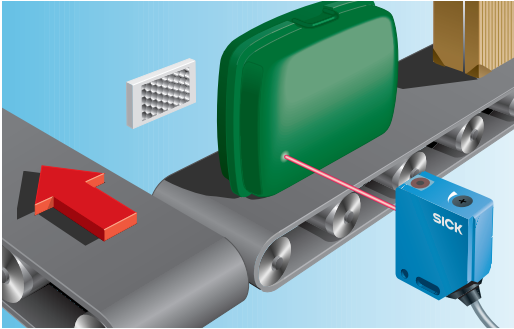

The use of laser diodes allows greater scanning ranges while simultaneously maintaining a high resolution. Focus ranges can be set with high precision.

Photoelectric reflex switches for detecting transparent objects

These reflex photoelectric switches are characterised by their extremely low switching hysteresis. Even slight light attenuation between the sensor and reflector, caused by e.g. glass bottles or even PET bottles, is detected reliably. A newly developed system check continuously corrects the switching threshold elec-

▼ Detection of transparent objects

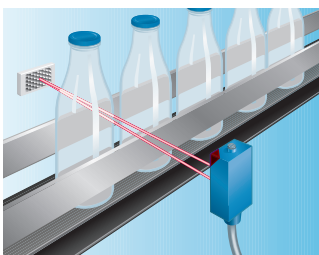

tronically to adapt to the gradual accumulation of dirt, which would otherwise lead to a system failure.

Photoelectric switches with fibre-optic cable

In the case of photoelectric switches with fibre-optic cable, the sender and receiver are contained in a single housing. A separate fibre-optic cable is used for the sender and the receiver for operation as a through-beam system. For use as a proximity switch the sender and receiver fibre-optic cables are combined in one cable.

▼ Photoelectric switch with fibre-optic cable

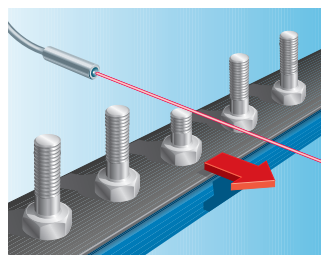

Polarisation filters

Photoelectric reflex switches – aligned with a reflector – detect the presence of objects. Interruption of the light beam, i.e. the absence of reflection, triggers a switching signal. Since the objects to be detected may, however, also have high-gloss or reflective surfaces (for example, stainless steel, aluminium or tin plate), any incorrect detection and false triggering must be fully eliminated.

Polarisation filters are an effective solution to this problem. One of these strip filters aligns the freely oscillating emitted light into one polarisation plane, e.g. horizontal. If the light beam is unbroken, it hits an optically active reflector which rotates the polarisation plane by 90° and the light is reflected vertically. The rotated beam returns to the device via a second polarisation filter (rotated

accordingly) in front of the receiver element of the photoelectric reflex switch. However, since the polarisation plane of the light reflected by a glossy object is not rotated, the reflected light remains in a horizontal plane and is not detected by the vertically polarised receiver – which is exactly the way it should be.

The object is detected as an interruption along the unbroken light beam – the switching output is set.

Limits of mirror reliability
Photoelectric reflex switches are not affected by surface reflections from shiny products. However, problems may be experienced with optically transparent materials such as Perspex (Plexiglas/Lucite) lids, laminated foil or foil transitions. These potential problems do not stem from the surface gloss of the material, but from its reverse side.

▼ Polarisation filter

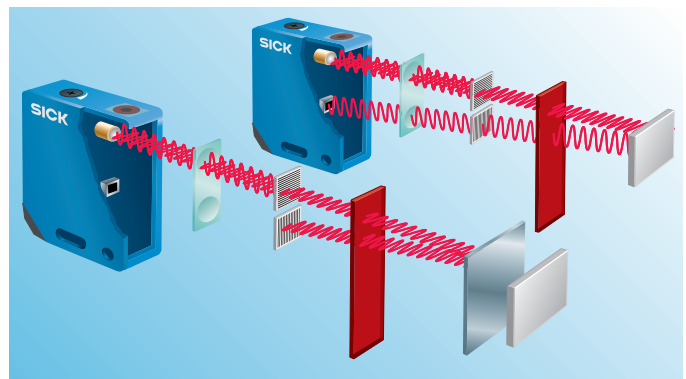



Perspex (polymethyl methacrylate resin) exhibits properties of polarisation plane rotation, by virtue of its molecular structure. When polarised light penetrates through such a medium, it may be turned through 45° in comparison to its original direction of oscillation. When the reverse side of the material reflects the same light back through the material, a further 45° rotation occurs. The resultant 90° rotation of the light, simulates closely the effect of returned light from a prismatic reflector and may result in such materials not being detected reliably. It should be possible to eliminate these effects by reducing the system sensitivity slightly by means of the sensitivity potentiometer. A further improvement can be achieved by changing the scanning angle of the sensor in relation to the surface of the object.

Position finders

The DMP position finder is an optoelectronic sensor which is used for fine positioning in handling and warehousing systems.

At, for example, transfer and docking stations, varying temperature- or load-dependent geometrical variations make fine positioning essential.

The DMP position finder, used especially for fine positioning in the x- and y-axis, was developed in order to solve this problem.

The device functions using reflectors. It always adapts itself to the actual conditions on-site, ensuring reliable storage, retrieval and docking procedures.

Positioning

The positioning method is used to precisely position objects, e.g. in handling and warehousing systems.

It is based on the measurement of light which a reflector distributes over the receiver element of a suitable sensor. The device emits a laser pulse, the reflection of which is projected on a 1,024 bit receiver array in the sensor. In this "capture range", the position sensor issues information concerning the direction of travel, e.g. for a high-bay stacker, via two analogue outputs (one for the x-axis and one for the y-axis). This

▼ Position finder

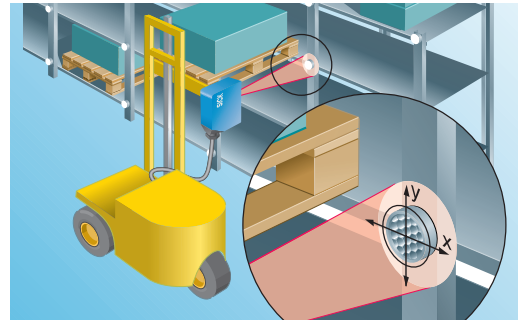

information can then be used to move the handling device to precisely the desired position.

The position of the light distributed across the receiver field is continuously used as a control variable.

Fine positioning is completed when the light distribution finally concentrates at the centre of the receiver array.

systems actuated by the sensor to start too early.

This function ensures that the switching outputs are only released after the device has successfully completed a self-test to establish whether it is functioning correctly – a procedure which can take up to 150 ms depending on the type of sensor.

Prevention of false triggering at start-up

With electronic devices, the point at which power is supplied (i.e. start-up) is not the point at which the sensor functions are ready for normal operation. The electronics of the device first check certain operating states. SICK optoelectronic sensors have an electronic function to prevent false triggering at start-up in order to ensure that any false pulse (which may occur under certain circumstances) does not lead to spurious switching or cause

R

Reflex light grids

Reflex light grids function according to the reflection principle.

▼ Reflex light grid

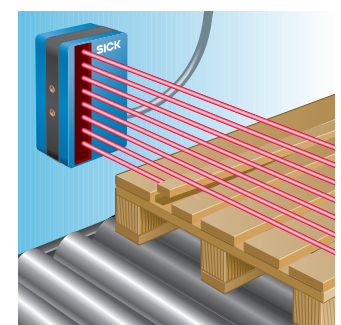

SENSICK Technology

A suitable reflector, which reflects the emitted light back to the receiver element of the sensor, is mounted opposite the sensor's exit window. A two-dimensional detection plane is produced between the sensor and reflector. Light grids are used to detect objects, to determine the height or length of objects, or to detect irregularly shaped objects.

Repeatability R

Switching point difference for the useful sensing range between two consecutive measurements under identical conditions.

Requirements for explosion-protected electrical equipment

An explosive atmosphere may form wherever dust, combustible gases or inflammable liquids are produced, transported, processed or stored. An explosion occurs when all three of the following factors exist simultaneously:

- Combustible material: e.g. gas, vapour, mist, dust;
- Sufficient oxygen: e.g. in the surrounding air
- Ignition source: e.g. sparks or hot surfaces.

Sensors for explosive areas: We are offering devices which have been specially devel-

▼ Responsibility of the sensor and machine manufacturers

Responsibility of the sensor manufacturer	Responsibility of the machine manufacturer				Definition (94/9/EEC) explosive atmosphere is present	Certification by
	Usable in Zone (gas)	Also usable in Zone (gas)	Usable in Zone (dust)	Also usable in Zone (dust)		
1G/1D	0 (0)	1 and 2	20 (10)	21 and 22	permanently or long-term or frequently	Named body
2G/2D	1 (1)	2	21 (11), Zone 22 "Conductive dust"	22	Occasionally	Named body
3G/3D	2 (2)	---	22 Zone non-"conductive dust" (nothing comparable)	22	Occasionally	Named body

G = gas, D = dust; () = old name in brackets

▼ SENSICK ATEX sensor technology

Category	Industrial Sensors			
	Photoelectric sensors	Inductive proximity sensors	Magnetic proximity sensors	Magnetic cylinder sensors
1G	---	---	---	---
1D	---	---	---	---
2G	W24Exi	IM08 IM12 IM18 IM30	MM12 MM18	MZR2 MZZ1 MZP3 MZP4
2D	---	---	---	---
3G	W18-3Ex W27-3Ex	---	---	MZT6
3D	W18-3Ex W27-3Ex WTR2Ex	---	---	MZT6

Accessories: isolation amplifier EN 2 Ex: The intrinsically safe circuits of the isolation amplifier are suitable for Zones 0, 1, 2, 20, 21 and 22. The device itself must not be installed in Zones 0, 1, 2, 20, 21 and 22.

oped for explosive environments. These are designed according to the relevant standards based on the Directive 94/9/EEC (ATEX). Depending on the design, the devices can be used in Zones 1 and 2 (gas) as well as in Zone 22 (non-conductive dusts).

S

Shingle detection

Magazines, board or other ribbed objects can be very reliably counted. A particular advantage is the fact that a varying height level does not have any effect on detection since the sensor

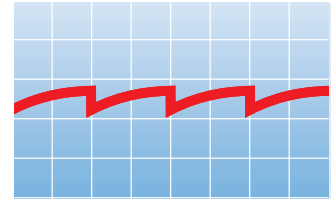

▼ Magazines being counted with DMH multifunction sensor



functions according to the differential principle. Only the defined change in height, irrespective of its position, is evaluated.

Status indicator

The forced triggering of the output (low-resistance) is indicated by an LED. With some sensors, standby is indicated by a second LED.

T

Teach-in

The term “Teach-in” refers to the programming of an evaluation module with one or more features of an object being tested or scanned. This is possible with a large number of photoelectric switches, photoelectric proximity switches, contrast scanners, colour sensors, luminescence scanners and light section sensors. To teach-in the features of an object, the object must first be placed in the light beam of the optoelectronic sensor. The reflectivity is evaluated in the receiver of the device. The detected switching threshold is then stored by pressing a button on the device or via the external control line. The advantage of “Teach-in”: The switching threshold is set electronically (and no longer by using potentiometers) simplifying and speeding up commissioning or adaptation to new applications.

Temperature drift

Shifting of the switching point caused by a change in ambient temperature.

The measurement of the time-of-flight of light

The time between the emission of a light pulse and the reception of its reflection is converted into a distance proportional to the propagation time.

Through-beam photoelectric switches

The through-beam photoelectric switch consists of two devices: the sender and receiver. The separate device configuration makes large scanning ranges possible. The use of laser diodes allows greater scanning ranges while simultaneously maintaining a high resolution. Focus ranges can be set with high precision.

▼ Through-beam photoelectric switch

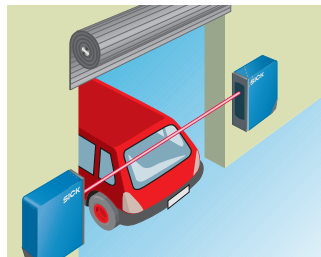

Triangulation measurement

The size of the light spot on the CMOS is dependent on the distance of the detected object. Consequently, the calculation of the signals gives a linear output signal depending on the distance of the object.

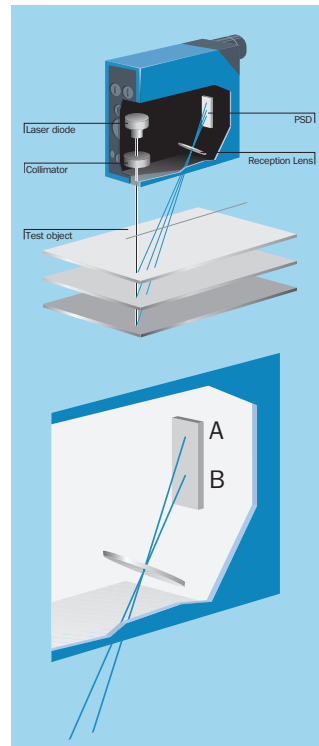

U

Ultrasonic sensors

The measurement principle of ultrasonic sensors is based on the time taken for ultrasonic to travel through the medium air. The signals are transmitted in defined “pack-

ages”. With the help of its processing electronics, the transceiver evaluates the time taken between the transmission of a sound “package” and the arrival of the reflection from an object. As a result, either a signal proportionate to the distance is sent via an analogue interface, or a switching signal depending on a previously set distance parameter is sent through a binary output. The accuracy of the measurement and the maximum scanning range lie within a tolerance range which depends mainly on the state of the carrier medium air and the roughness of the object in question.

W

Wire draw encoder

Wire draw encoder consist of wire draw mechanism and encoder. The rotation of the drum is proportional to the length being measured. This movement is counted by an encoder and converted to a measuring signal. This provides high-resolution position or distance information for linear measurement paths, even under difficult ambient conditions. Precise linear guidance, as required for other length measurement systems, is not necessary.