

# Altivar 312 variable speed drives

for three-phase motors from 0.25 hp (0.18 kW) to 20 hp (15 kW)

eCatalog

2014



This page was intentionally left blank.

---

■ <b>Introduction.....</b>	<b>4</b>
□ Applications .....	4
□ Product.....	5
□ Functions.....	6
■ <b>Specifications .....</b>	<b>22</b>
□ Environmental.....	22
□ Connection.....	22
□ Drive .....	23
□ Electrical Power .....	23
□ I/O & Control .....	24
□ Communication Port.....	26
□ Torque .....	27
□ Special Uses .....	27
■ <b>Short Circuit Current Ratings.....</b>	<b>28</b>
■ <b>Selection Table.....</b>	<b>32</b>
■ <b>Dimensions .....</b>	<b>33</b>
■ <b>Accessories &amp; Options.....</b>	<b>35</b>
□ Accessories .....	35
□ Replacement Parts.....	35
□ Communication Buses & Networks.....	36
□ Configuration Tools.....	42
□ Braking Resistors.....	44
□ Line Chokes .....	46
□ EMC Filters.....	48
□ Output Filters.....	50
□ Motor Chokes .....	50
□ Ferrite Suppressors.....	50
□ Wiring Diagrams.....	52
□ Installation Recommendations.....	54
□ Combinations .....	56
■ <b>Quality Assurance .....</b>	<b>58</b>
■ <b>Services &amp; Support.....</b>	<b>60</b>

# Altivar 312

## variable speed drives

## Introduction



### Introduction

The Altivar™ 312 drive is a frequency inverter for 200 to 600 V three-phase asynchronous motors from 0.25 hp (0.18 kw) to 20 hp (15 kW).

The Altivar 312 drive is robust, compact and easy to install. Its integrated functions are particularly suitable for the requirements of applications involving simple industrial machines.

By taking into account product setup and use, starting at the design stage, we are able to offer a reliable, cost-effective solution to manufacturers of simple machines and installers.

With its various communication cards that are available as options, the Altivar 312 drive integrates perfectly in the main control system architectures.

Examples of solutions provided:

- Numerous options for loading, editing and saving drive configurations using various tools, such as the SoMove™ setup software, remote display terminals and the Simple Loader and Multi Loader configuration tools.
- Adaptation to industrial communication buses and networks by simply replacing the drive control I/O card with one of the communication cards
- Simple user interface makes setup easy, and enables those using it to adapt quickly.



Materials handling

### Applications

The Altivar 312 drive incorporates functions that are suitable for the most common applications, including:

- Material handling (small conveyors, hoists, etc.)
- Packing/packaging machines (small bagging machines, labeling machines, etc.)
- Special machines (mixers, kneaders, textile machines, etc.)
- Pumps, compressors, fans



Packaging and packing



Pumps, compressors, fans

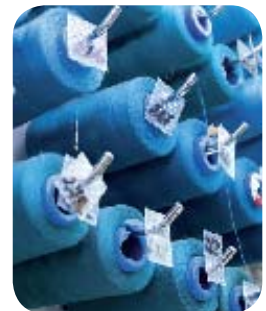

Textile machines

# Altivar 312 variable speed drives

## Introduction



ATV312H037M2

ATV312HU15N4



ATV312HU30N4



ATV312HU75N4

## Product

The Altivar 312 range of variable speed drives covers motor power ratings from 0.25 hp (0.18 kW) to 20 hp (15 kW) with four types of power supply:

- **ATV312H●●●M2**: 200 V to 240 V single-phase, 0.25 hp (0.18 kW) to 3 hp (2.2 kW)
- **ATV312H●●●M3**: 200 V to 240 V three-phase, 0.25 hp (0.18 kW) to 20 hp (15 kW)
- **ATV312H●●●N4**: 380 V to 500 V three-phase, 0.5 hp (0.37 kW) to 20 hp (15 kW)
- **ATV312H●●●S6**: 525 V to 600 V three-phase, 1 hp (0.75 kW) to 20 hp (15 kW)

Several drives can be mounted side by side to save space.

The Altivar 312 drive integrates the Modbus and CANopen communication protocols as standard. The protocols can be accessed via the RJ45 connector on the underside of the drive.

In addition to the Modbus and CANopen protocols that can be accessed as standard, the Altivar 312 drive can be connected to the main industrial communication buses and networks by replacing the drive's control I/O card with one of the communication cards that are available as options: CANopen Daisy chain, DeviceNet and Profibus DP. The Modbus TCP network and the Fipio™ bus are also accessible via dedicated gateways. See page 36.

The entire range complies with international standards UL 508C, IEC 61800-2 and IEC 61800-3, CSA, C-Tick, NOM and GOST certifications. It has been developed to meet the requirements of environmental directives (RoHS) and those of the European Directives to obtain the CE mark.

### Electromagnetic compatibility (EMC)

The incorporation of EMC filters in ATV312H●●●M2 and ATV312H●●●N4 drives and compliance with EMC requirements simplify installation and provide a very economical means of ensuring devices meet the criteria to receive the CE mark. This filter can be disconnected via a jumper or a moveable wire with tag. The ATV312H●●●M3 and ATV312H●●●S6 drives are designed without an EMC filter.

Filters are available as an option and can be installed by the customer to reduce the emission levels of ATV312H●●●M2, ATV312H●●●M3 and ATV312H●●●N4 drives. See page 48.



EMC filter (VW3A31405)

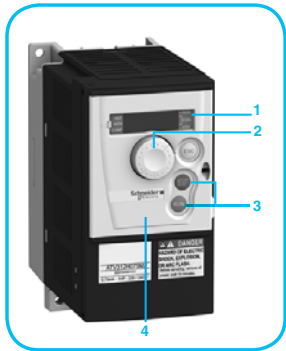

ATV312H075M2 with front panel door closed, without cover 4:  
STOP/RESET and RUN keys accessible



Remote graphic display terminal



Remote display terminal

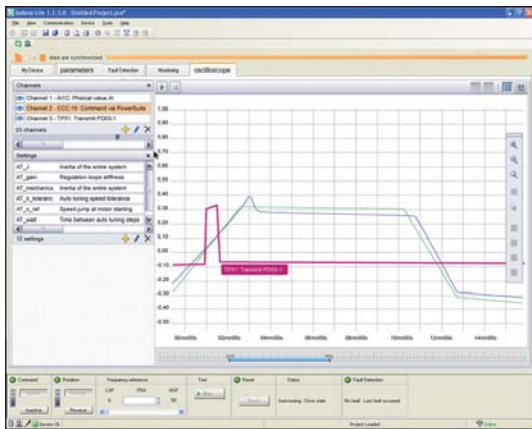

Oscilloscope function in the SoMove setup software



Multi-Loader tool  
(VWA8121)



Simple loader tool  
(VWA8120)

## Product (continued)

### External accessories and options

External accessories and options can be used with Altivar™ 312 drives:

- UL Type 1 conformity kits, plates for direct mounting on 35 mm DIN rails, etc.
- Braking resistors, line chokes, additional EMC input filters, output filters, etc.

### HMI and configuration tools

#### On-board Human/Machine Interface

The 4-digit display **1** displays drive states, detected faults and parameter values. The navigation button **2** is used to navigate through the menus, modify values and change the motor speed in local mode.

The RUN and STOP/RESET keys **3** are used to control motor starting and stopping in local mode. These two keys can be made accessible on the front panel by removing the cover **4** from the door.

#### HMI terminals

The Altivar 312 drive can be connected to a remote display terminal or a remote graphic display terminal, which are available as options.

The remote display terminal can be mounted on an enclosure door with IP 54 or IP 65 degree of protection. It provides access to the same functions as the Human-Machine interface.

The remote graphic display terminal, with its “full text” display in the user’s language, provides a user-friendly interface for configuration, debugging or maintenance. See page 42.

#### SoMove™ setup software for PCs

The SoMove™ setup software is used to configure, adjust and debug the Altivar 312 drive with the Oscilloscope function, and also for maintenance of this drive, like all other Schneider Electric drives and soft starters.

It can be used with a direct connection or a Bluetooth® wireless connection. See page 43.

#### Simple Loader and Multi-Loader configuration tools

The Simple Loader tool enables one powered-up drive’s configuration to be duplicated on another powered-up drive.

The Multi-Loader tool enables configurations to be copied from a PC or a powered up drive and duplicated on another powered-up drive. See page 43.

## Functions

The Altivar 312 drive has six logic inputs, three analog inputs, one logic/analog output and two relay outputs.

The main functions available are as follows:

- Motor and drive protection
- Linear, S, U or customized acceleration and deceleration ramps
- Local control of the speed reference using the navigation button
- +/- speed
- 16 preset speeds
- PI regulator and references
- 2-wire/3-wire control
- Brake sequence
- Automatic catching a spinning load with speed detection and automatic restart
- Detected fault configuration and stop type configuration
- Saving the configuration in the drive

Several functions can be assigned to one logic input.



## Functions

### *Drive factory configuration*

Presentation	Page 8
--------------	--------

### *Human-Machine Interface (HMI)*

Description	Page 8
-------------	--------

### *Application functions*

Operating speed range	Page 9
Acceleration and deceleration ramp times	Page 9
Acceleration and deceleration ramp profiles	Page 9
Ramp switching	Page 10
Automatic adaptation of deceleration ramp	Page 10
Voltage/frequency ratio	Page 11
Auto-tuning	Page 11
Switching frequency, noise reduction	Page 11
Skip frequencies	Page 12
Speed reference	Page 12
Analog inputs	Page 12
Preset speeds	Page 12
+/- speed	Page 13
Save reference	Page 13
Jog operation	Page 14
Command and reference channels	Page 14
Reference switching	Page 14
Summing inputs	Page 14
PI regulator	Page 15
Current limit switching	Page 15
Limiting low speed operating time	Page 15
Motor switching	Page 15
Control mode switching	Page 16
2-wire control	Page 16
3-wire control	Page 16
Forced local mode	Page 16
Freewheel stop	Page 16
Fast stop	Page 16
DC injection stop	Page 16
Brake control	Page 17
Limit switch management	Page 17
Monitoring	Page 17
Detected fault management	Page 18
Detected fault reset	Page 18
General reset (disables all detected faults)	Page 18
Controlled stop on loss of line supply	Page 18
Stop mode in the event of a detected fault	Page 18
Automatic catching of a spinning load with speed detection ("catch on the fly")	Page 19
Automatic restart	Page 19
Derated operation in the event of an undervoltage	Page 19
Detected fault relay, unlocking	Page 19
Resetting operating time to zero	Page 19
Motor thermal protection	Page 20
Drive thermal protection	Page 20
R1, R2 relay configuration	Page 20
AOC/AOV analog outputs	Page 21
Saving and retrieving the configuration	Page 21

### *Function compatibility table*

Presentation	Page 21
--------------	---------

## Functions (continued)

### Drive factory configuration

The Altivar 312 drive is configured to allow a quick start-up for most applications.

Factory configuration:

- Nominal motor frequency: 50 Hz
- Motor voltage: 230 V (ATV312H●●●M2, ATV312H●●●M3),  
400 V (ATV312H●●●N4) or 600 V (ATV312H●●●S6)
- Linear ramp times: 3 seconds
- Low speed (LSP): 0 Hz/High speed (HSP): 50 Hz
- Normal stop mode on deceleration ramp
- Stop mode in the event of a detected fault: freewheel
- Motor thermal current = nominal drive current
- Standstill injection braking current = 0.7 x nominal drive current, for 0.5 seconds
- Constant torque operation with sensorless flux vector control
- Logic inputs:
  - 2 directions of operation (LI1, LI2), 2-wire control
  - 4 preset speeds (LI3, LI4): LSP (low speed), 10 Hz, 15 Hz, 20 Hz
- Analog inputs:
  - AI1 speed reference (0 + 10 V)
  - AI2 (0 ± 10 V) summing of AI1
  - AI3 (4-20 mA) not configured
- Relay R1: detected fault relay
- Relay R2: not assigned
- Analog output AOC: 0-20 mA, image of the motor frequency
- Automatic adaptation of the deceleration ramp in the event of overbraking
- Switching frequency 4 kHz, random frequency

### Human-Machine Interface (HMI)

#### Description

- 1 Display:
  - 4-digit display
  - Display of numeric values and codes
  - Indication of the unit of the displayed value
- 2 Display of the drive status:
  - **REF**: Reference mode. This mode is used to display the motor frequency reference of the active reference channel (terminals, local mode, remote display terminal or Modbus serial link). In local mode, the reference can be modified using the navigation button 4, if the function is configured.
  - **MON**: Monitoring mode. This mode is used to display the monitoring parameters when the drive is running.
  - **CONF**: Configuration mode. This mode is used to configure the drive parameters. These parameters can be modified using the SoMove setup software.
- 3 Use of the keys:
  - **MODE** is used to access one of the following modes:
    - Reference mode REF
    - Monitoring mode MON
    - Configuration mode CONF

**Note:** This key cannot be accessed if the front panel door is closed.

- **ESC**: Aborts a value, a parameter or a menu to return to the previous selections
- **STOP/RESET**: Local motor stop command, clears drive detected faults (key active in factory configuration)
- **RUN**: Local motor run command, if its activation is programmed

- 4 Use of the navigation button:
  - Rotate: Increases or decreases the value, or goes to the next value
  - Press: Saves the current value or selects the value
  - The button can be used as a potentiometer in local mode

- 5 Cover that can be removed for access to the RUN and STOP/RESET keys.

- 6 It is possible to lock the front panel door with a lead seal.



ATV312H075M2 with front panel door closed, with cover 5: STOP/RESET and RUN keys not accessible

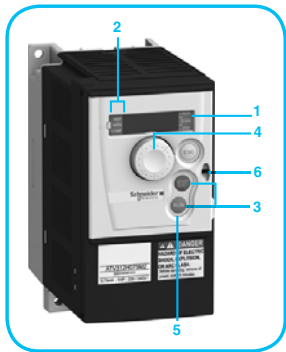

ATV312H075M2 with front panel door closed, without cover 5: STOP/RESET and RUN keys accessible

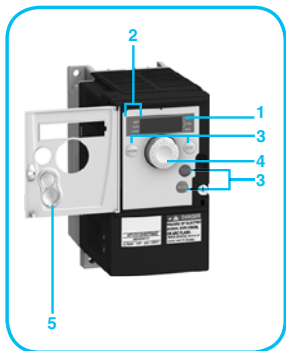

ATV312H075M2 with front panel door open

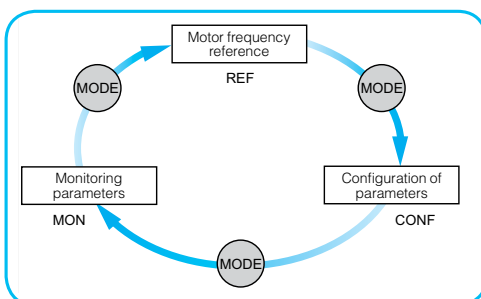

3 operating modes: REF, MON and CONF



## Functions (continued)

### Application Functions

#### Operating speed range

This function is used to determine the 2 frequency limits which define the speed range permitted by the machine under actual operating conditions for all applications with or without overspeed.

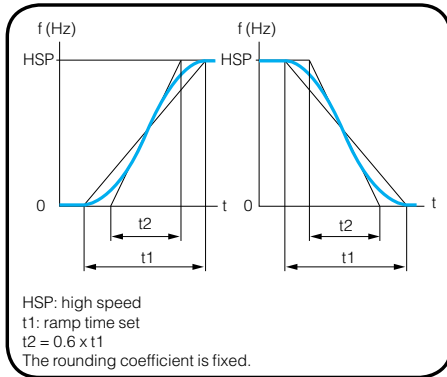

S ramps

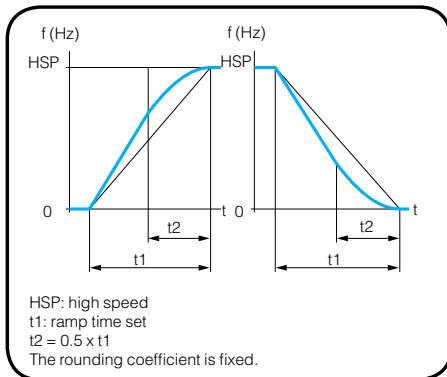
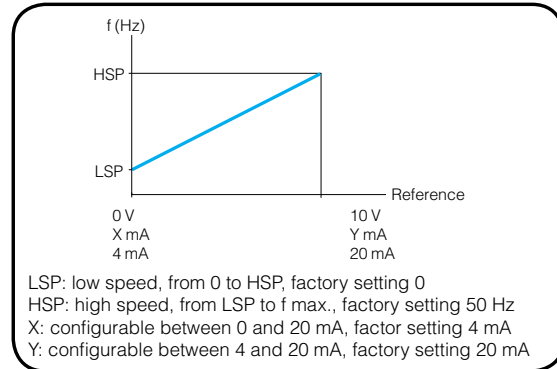

U ramps

#### Acceleration and deceleration ramp times

This function is used to define acceleration and deceleration ramp times according to the application and the machine dynamics.

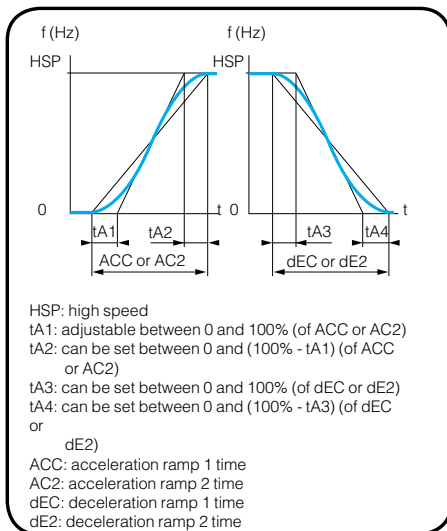
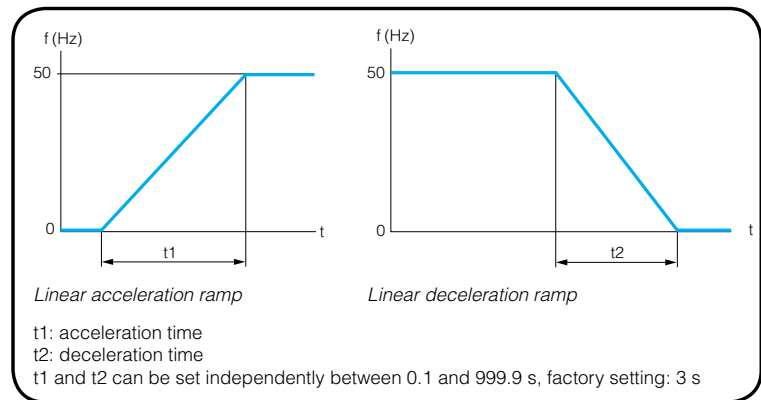

Customized ramps

#### Acceleration and deceleration ramp profiles

These enable a gradual change in the output frequency starting from a speed reference, following a linear profile or a preset profile.

#### ■ S ramps

For applications such as material handling, packaging and passenger transport, the use of S ramps takes up mechanical backlash, eliminates jolts, and limits "non-following" of speed during rapid transient operation of high-inertia machines.

#### ■ U ramps

U ramps are specifically for pumping applications, for example an installation with centrifugal pump and non-return valve. They provide better control of closing of the non-return valve.

Selecting linear, S, U or customized profiles assigns both the acceleration and deceleration ramps.

### Functions (continued)

#### Ramp switching

This function is used to switch two acceleration and deceleration ramp times, which can be adjusted separately.

Ramp switching can be enabled by:

- A logic input
- A frequency threshold
- A combination of logic input and frequency threshold

This function is suitable for:

- Material handling with smooth starting and approach
- Machines with fast steady state speed correction

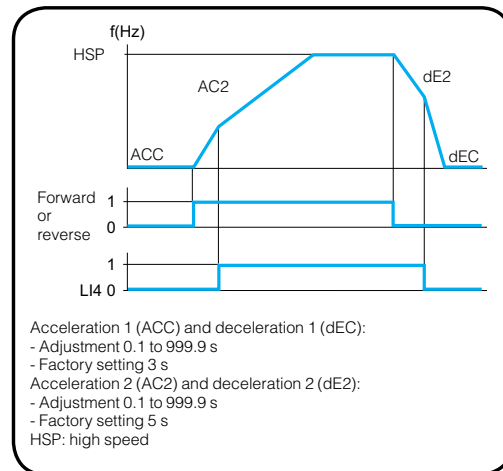

Example of switching using logic input LI4

#### Automatic adaptation of deceleration ramp

This function is used to automatically adapt the deceleration ramp if the initial setting is too low for the inertia of the load. It avoids the drive locking in the event of an overbraking detected fault.

The function is suitable for all applications which do require precise stopping and do not use braking resistors.

Automatic adaptation must be cancelled if the machine has position control with stopping on a ramp and a braking resistor installed. It is automatically disabled if the brake sequence is configured.

### Functions (continued)

#### *Voltage/frequency ratio*

- Motor and power supply specifications
  - This function is used to determine the limit values for the voltage/frequency ratio according to the specifications of the line supply, motor and application. The following values should be set for constant or variable torque applications with or without overspeed:
    - The base frequency corresponding to the line supply
    - The nominal motor frequency (in Hz) given on the motor rating plate
    - The nominal motor voltage (in V) given on the motor rating plate
    - The maximum output frequency of the drive (in Hz)

#### *Type of voltage/frequency ratio*

This is used to adapt the voltage/frequency ratio to the application in order to optimize performance for the following applications:

- Constant torque applications (machines with average loads operating at low speed) with motors connected in parallel or special motors (e.g. resistive cage motor): ratio L
- Variable torque applications (pumps, fans): ratio P
- Machines with heavy loads operating at low speed, machines with fast cycles, with (sensorless) flux vector control: ratio n
- Energy saving, for machines with slow torque and speed variations: ratio nLd.

The voltage is automatically reduced to minimum according to the necessary torque.

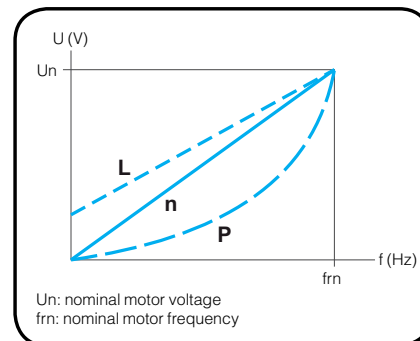

#### *Auto-tuning*

Auto-tuning can be performed:

- Voluntarily by the operator using dialog tools via local control or the serial link
- Each time the drive is switched on
- On each run command
- By enabling a logic input

Auto-tuning is used to optimize application performance.

#### *Switching frequency, noise reduction*

Adjusting the switching frequency setting reduces the noise generated by the motor. The switching frequency is modulated randomly in order to avoid resonance. This function can be disabled if it causes instability.

High frequency switching of the intermediate DC voltage can be used to supply the motor with a current wave that has little harmonic distortion. The switching frequency can be adjusted during operation to reduce the noise generated by the motor.

Value: 2 to 16 kHz. Factory setting 4 kHz

For all applications which require low motor noise.

## Functions (continued)

### Skip frequencies

This function suppresses one or two critical speeds that may cause mechanical resonance.

It is possible to prohibit prolonged operation of the motor on 1 or 2 frequency bands ( $\pm 1$  Hz), around an adjustable frequency on the speed range.

This function is suitable for lightweight machines, bulk product conveyors with an unbalanced motor, fans and centrifugal pumps.

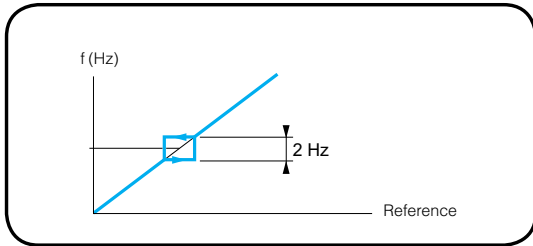

Motor speed change depending on the skip frequency reference

### Speed reference

The speed reference can come from different sources, depending on the drive configuration:

- References provided by 3 analog inputs
  - The navigation button reference
  - The +/- speed function via logic input, using the keypad or remote display terminal keys
  - The remote display terminal reference
  - Speed references provided by the communication bus or networks
- These sources are managed by programming the reference functions and channels.

### Analog inputs

There are 3 analog inputs:

- 2 voltage inputs:
  - 0-10 V (AI1)
  - $\pm 10$  V (AI2)
- 1 current input:
  - X-Y mA (AI3), where X is configurable between 0 and 20 mA, and Y is configurable between 4 and 20 mA

### Preset speeds

This function is used to switch preset speed references.

Choose between 2, 4, 8 or 16 preset speeds.

Enabled by means of 1, 2, 3 or 4 logic inputs.

The preset speeds are adjustable in increments of 0.1 Hz from 0 Hz to 500 Hz.

This function is suitable for material handling and machines with several operating speeds.

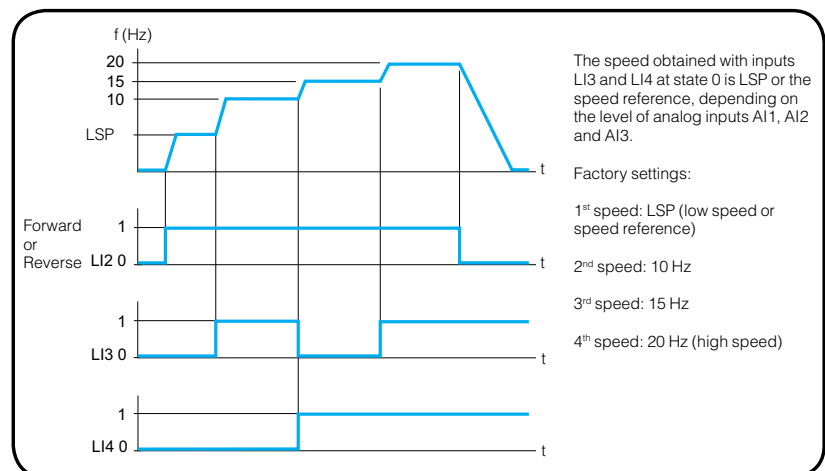

Example of switching using logic input LI4

## Functions (continued)

### +/- speed

This function is used to increase or decrease a speed reference by means of 1 or 2 logic inputs, with or without the last reference being saved (motorized potentiometer function).

This function is suitable for centralized control of a machine with several sections operating in one direction or for control by a pendant control station of a material handling crane with two operating directions.

Two types of operation are available:

- Use of single-action buttons: two logic inputs are required in addition to the operating direction(s).

The input assigned to the + speed command increases the speed, the input assigned to the - speed command decreases the speed.

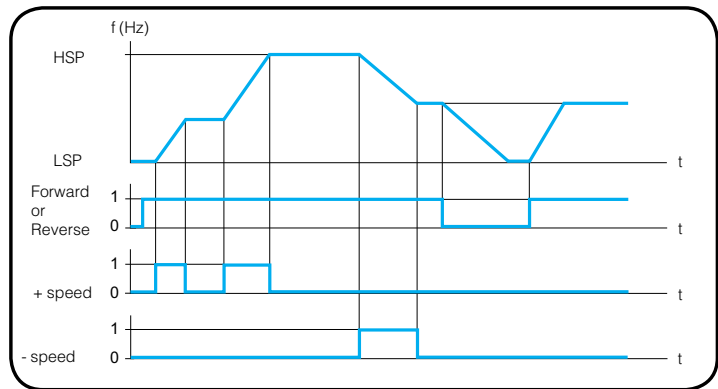

Motor speed change depending on the skip frequency reference

Logic inputs:

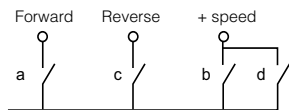

a and c: 1<sup>st</sup> press  
b and d: 2<sup>nd</sup> press

	Released (- speed)	1st press (speed maintained)	2nd press (+ speed)
Forward button	-	a	a and b
Reverse button	-	c	c and d

- Use of double-action buttons (only one logic input assigned to + speed is necessary).

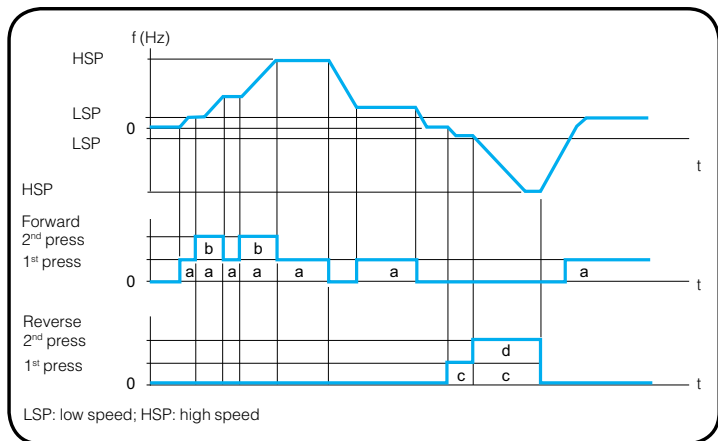

Example with double-action buttons and 1 logic input

**Note:** This type of +/- speed control is incompatible with 3-wire control.

### Save reference

This function is associated with +/- speed control.

It enables the last speed reference prior to the loss of the run command or line supply to be read and saved. The saved reference is applied to the next run command.

## Functions (continued)

### Jog operation

This function is used for pulse operation with minimum ramp times (0.1 s), a limited speed reference and minimum time between 2 pulses. It is enabled by 1 logic input and pulses given by the operating direction command.

This function is suitable for machines with product insertion in manual mode (e.g. gradual movement of the mechanism during maintenance operations).

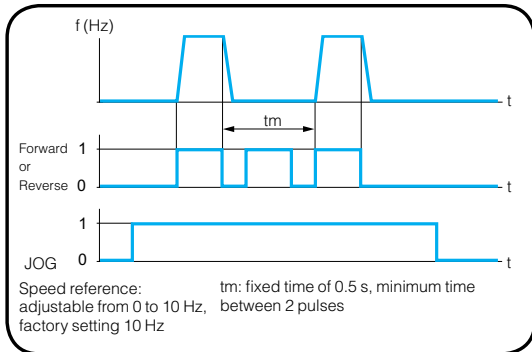

Example of jog operation

### Command and reference channels

There are several command and reference channels, which can be independent. Commands (forward, reverse, etc.) and speed references can be given via the following channels:

- Terminals (logic inputs and analog I/O)
- Local mode (STOP/RESET and RUN keys and navigation button)
- Remote display terminal
- Serial link:
  - Remote display terminal
  - Modbus control word
  - CANopen control word

The command channels and speed reference channels can be separate. E.g. speed reference issued by CANopen and command issued by the remote display terminal.

**Note:** The STOP/RESET keys on the Human-Machine interface keypad and the remote display terminal can retain their priority.

The Summing inputs and PI regulator functions only apply to one reference channel.

### Reference switching

Switching between 2 speed references can be enabled via:

- A logic input
- A bit in a Modbus or CANopen control word

Reference 1 is active if the logic input (or control word bit) is at 0. Reference 2 is active if the logic input (or control word bit) is at 1.

The reference can be switched with the motor running.

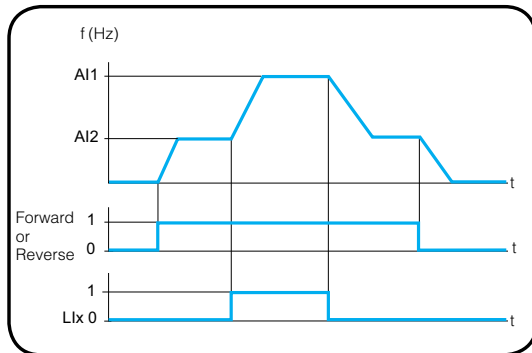

Example of reference switching

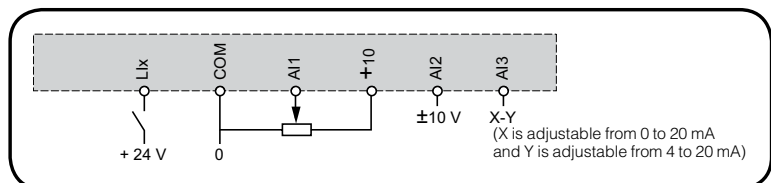

Connection diagram for reference switching

### Summing inputs

This function is used to add together 2 to 3 speed references from different sources. The references to be added together are selected from all the possible types of speed reference.

E.g.

- Reference 1 from AI1
- Reference 2 from AI2
- Reference 3 from AIP

**Drive speed reference** = reference 1 + reference 2 + reference 3.



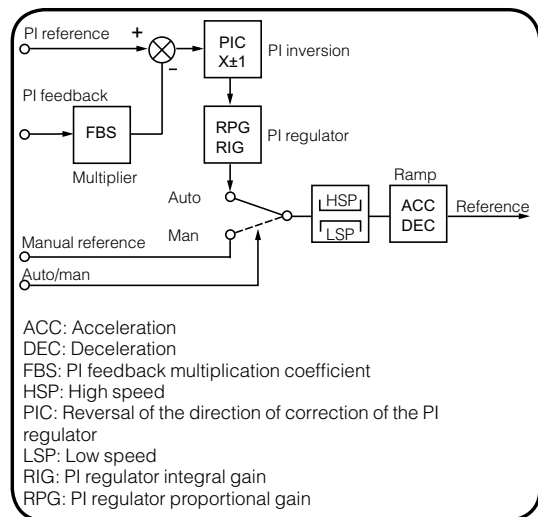

PI feedback

## Functions (continued)

### PI regulator

This function is used for simple control of a flow rate or a pressure with a sensor supplying a feedback signal adapted to the drive. It is suitable for pumping and ventilation applications.

- PI reference:
  - Internal regulator reference, adjustable from 0 to 100
  - Regulation reference selected from all the possible types of regulation reference
  - Preset PI references
- 2 or 4 preset PI references adjustable from 0 to 100, require the use of 1 or 2 logic inputs respectively
- Manual reference
  - Speed reference selected from all the possible types of speed reference
- PI feedback:
  - Analog input AI1, AI2 or AI3
- Auto/Man:
  - Logic input LI for switching operation to speed reference (Man) or PI regulation (Auto)

During operation in automatic mode, the process feedback can be adapted to correct inverse PI, adjust the proportional and integral gain, or apply a ramp (time = ACC - DEC) for establishing the PI action on starting and stopping. The motor speed is limited to between LSP and HSP.

**Note:** The PI function is incompatible with the Preset speeds and JOG functions. The PI reference can also be transmitted on line via the Modbus RS 485 serial link or via the CANopen bus.

### Current limit switching

A second current limit can be configured between 0.25 and 1.5 times the nominal drive current.

This function limits the torque and the temperature rise of the motor.

Switching between the two current limits can be enabled via:

- A logic input
- A bit in a Modbus or CANopen control word

### Limiting low speed operating time

The motor is stopped automatically after a period of operation at low speed (LSP) with a zero reference and a run command present.

This time can be set between 0.1 and 999.9 seconds (0 corresponds to an unlimited time). Factory setting: 0 s. The motor restarts automatically on the ramp when the reference reappears or if the run command is interrupted and then re-established.

This function is suitable for automatic stopping/starting of pressure-regulated pumps.

### Motor switching

This function allows two motors with different powers to be supplied alternately by the same drive. Switching must take place with the drive stopped and locked, using an appropriate sequence at the drive output.

The function can be used to adapt the motor parameters. The following parameters are switched automatically:

- Nominal motor voltage
- Nominal motor frequency
- Nominal motor current
- Nominal motor speed
- Motor cosine Phi (power factor)
- Selection of the type of voltage/frequency ratio for motor 2
- IR compensation, motor 2
- Motor frequency loop gain
- Motor stability
- Motor slip compensation

Motor thermal protection is disabled by this function.

Motor switching can be enabled by:

- A logic input
- A bit in a Modbus or CANopen control word

With hoisting applications, this function enables a single drive to be used for vertical and horizontal movements.

## Functions (continued)

### Control mode switching

Switching the command channel provides a choice of 2 control modes. Switching is enabled by:

- A logic input
- A bit in a Modbus or CANopen control word

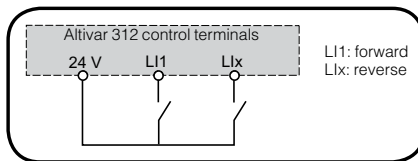

Wiring diagram for 2-wire control

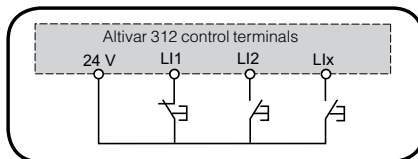

Wiring diagram for 3-wire control

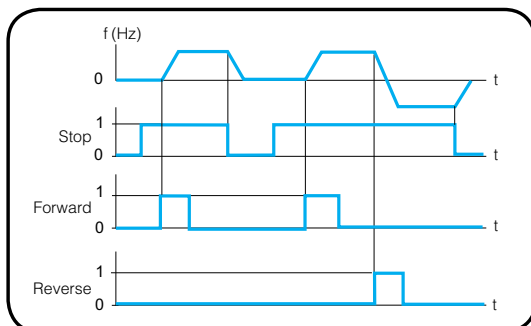

Example of 3-wire control operation

### 2-wire control

This function is used to control the direction of operation by means of a stay-put contact.

It is enabled by means of 1 or 2 logic inputs (one or two directions of operation).

This function is suitable for all non-reversing and reversing applications.

Three operating modes are possible:

- Detection of the state of the logic inputs
- Detection of a change of state of the logic inputs
- Detection of the state of the logic inputs with forward operation having priority over reverse

### 3-wire control

This function is used to control the operating direction and stopping by means of pulsed contacts.

It is enabled by means of 2 or 3 logic inputs (1 or 2 directions of operation).

It is suitable for all non-reversing and reversing applications.

### Forced local mode

Forced local mode imposes control via the terminals or display terminal and disables all other control modes.

The following references and commands are available for forced local mode:

- References AI1, or AI2, or AI3 and command via logic inputs
- Reference and command via RUN and STOP/RESET keys and the navigation button
- Reference and command via the remote display terminal

The changeover to forced local mode is enabled by a logic input.

### Freewheel stop

This stops the motor by resistive torque if the motor power supply is cut.

A freewheel stop is achieved by:

- Configuring a normal stop command as a freewheel stop (on disappearance of a run command or appearance of a stop command)
- Enabling a logic input

### Fast stop

This is used to achieve a braked stop with a deceleration ramp time (divided by 2 to 10) that is acceptable for the drive/motor unit without locking on an overbraking detected fault.

It is used for conveyors with electrical emergency stop braking.

A fast stop is achieved by:

- Configuring a normal stop as a fast stop (on disappearance of a run command or appearance of a stop command)
- By enabling a logic input

### DC injection stop

This function is used for low speed braking of high-inertia fans, or for maintaining torque when stopping fans located in an airflow.

A DC injection stop is achieved by:

- Configuring a normal stop as a DC injection stop (on disappearance of a run command or appearance of a stop command)
- Enabling a logic input

The DC value and the standstill braking time are adjustable.

## Functions (continued)

### Brake control

This function is used to manage control of an electromagnetic brake in synchronization with starting and stopping the motor to avoid jolts and speed detected errors.

The brake control sequence is managed by the drive.

Adjustable values for releasing the brake: current threshold and time delay

Adjustable values for engaging the brake: frequency threshold and time delay

Enabled by: relay logic output R2 or logic output AOC assigned to brake control.

This function is suitable for material handling applications with movements equipped with electromagnetic brakes (hoisting) and machines requiring holding brake control (unbalanced machines).

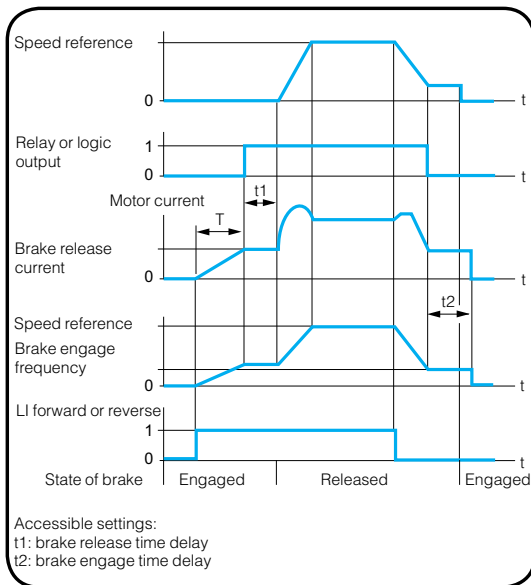

Brake control

### Principle:

#### Vertical hoisting movement:

- Maintains motor torque in an upward direction when the brake is being released and engaged, in order to hold the load and start smoothly as soon as the brake is released.

#### Horizontal hoisting movement:

- Synchronizes brake release with the build-up of torque during starting and brake engage at zero speed on stopping, to prevent jolting.

The recommended brake control settings for vertical hoisting applications are as follows (for horizontal hoisting applications, set the current threshold to zero):

#### Brake release current:

- Set the brake release current to the nominal current indicated on the motor. If, during testing, the torque is insufficient, increase the brake release current (the maximum value is imposed by the drive).

#### Acceleration time:

- For hoisting applications it is advisable to set the acceleration ramps to more than 0.5 seconds. Ensure that the drive does not change to current limiting. The same recommendation applies for deceleration.

Note: For a hoisting movement, a braking resistor should be used. Ensure that the selected settings and configurations will not result in dropping or loss of control of the load being lifted.

#### Brake release time delay $t_1$ :

- Adjust according to the type of brake. It is the time required for the mechanical brake to release.

#### Brake engage frequency:

- Set to twice the nominal slip, then adjust according to the result.

#### Brake engage time delay $t_2$ :

- Adjust according to the type of brake. It is the time required for the mechanical brake to engage.

### Limit switch management

This function is used to manage the operation of one or two limit switches (with 1 or 2 operating directions).

Each limit (forward, reverse) is associated with a logic input. The type of stop that occurs on detection of a limit is configurable as normal, freewheel or fast stop.

Following a stop, the motor is permitted to restart in the opposite direction only.

### Monitoring

The following data can be displayed:

- Frequency reference
- Internal PI reference
- Frequency reference (absolute value)
- Output frequency applied to the motor (value signed in two's complement)
- Output frequency in customer units
- Current in the motor
- Motor power: 100% = nominal power
- Line voltage
- Motor thermal state: 100%: nominal thermal state, 118%: motor overload threshold
- Drive thermal state: 100%: nominal thermal state, 118%: drive overload threshold
- Motor torque: 100% = nominal torque
- Last detected fault
- Operating time
- Auto-tuning status
- Configuration and state of logic inputs
- Configuration of analog inputs

---

## Functions (continued)

---

### *Detected fault management*

---

There are various operating modes in the event of resettable detected faults:

- Freewheel stop
- The drive switches to the fallback speed
- The drive maintains the speed at which it was operating when the detected fault occurred, until the detected fault disappears
- Stop on ramp
- Fast stop

The following resettable faults are detected:

- Drive overheating
- Motor overheating
- CANopen bus detected fault
- Modbus serial link failure
- External detected faults
- Loss of 4-20 mA signal

---

### *Detected fault reset*

---

This function is used to clear the last detected fault by means of a logic input.

The restart conditions after a reset are the same as those for a normal power-up.

Resets the following detected faults: overvoltage, overspeed, external detected fault, drive overheating, output phase loss, DC bus overvoltage, loss of 4-20 mA reference, load slipping, motor overload if the thermal state is less than 100%, serial link detected fault.

Line supply undervoltage and input phase loss detected faults are reset automatically when

the line supply is restored.

This function is suitable for applications where the drives are difficult to access, for example on moving parts or in material handling systems.

---

### *General reset (disables all detected faults)*

---

This function disables all detected faults, including thermal protection (forced operation), and can result in irreparable damage to the drive.

**This invalidates the warranty.**

This function is suitable for applications where restarting may be crucial (conveyor in an oven, smoke extraction system, machines with solidifying products that need to be removed).

The function is enabled by a logic input.

Detected fault monitoring is active if the logic input is at state 1.

All detected faults are reset on a change of state  $\downarrow$  of the logic input.

---

### *Controlled stop on loss of line supply*

---

This function is used to control motor stopping on a loss of line supply.

It is suitable for material handling, machines with high inertia, continuous product processing machines.

Possible types of stop:

- Locking of the drive and freewheel stop
- Stop which uses the mechanical inertia to maintain the drive power supply as long as possible
- Stop on ramp
- Fast stop (depends on the inertia and the braking ability of the drive)

---

### *Stop mode in the event of a detected fault*

---

The type of stop that occurs on detection of a fault is configurable as normal, freewheel or fast for the following detected faults:

- External detected fault (detection enabled by a logic input or a bit in a Modbus or CANopen control word)
- Motor phase loss detected fault

If an output contactor is being used between the drive and the motor, the motor phase loss detected fault should be disabled.

---

### Functions (continued)

---

#### *Automatic catching of a spinning load with speed detection ("catch on the fly")*

---

This function is used to restart the motor smoothly after one of the following events, provided the run command is still present:

- Loss of line supply or power off
- Detected fault reset or automatic restart
- Freewheel stop

On disappearance of the event, the rms speed of the motor is detected in order to restart on a ramp from this speed and return to the reference speed. Speed detection can take up to 1 s depending on the initial deviation.

This function is automatically disabled if the brake sequence is configured.

It is suitable for machines for which the motor speed loss is negligible during the loss of line supply (such as machines with high inertia, fans and pumps driven by a residual flow, etc.).

---

#### *Automatic restart*

---

This function enables the drive to be restarted automatically after it has locked in detected fault mode, provided the detected fault has disappeared and the other operating conditions permit a restart.

This restart is performed by a series of automatic attempts separated by increasingly longer waiting periods of 1 s, 5 s, 10 s, then 1 minute for subsequent periods.

The restart procedure can last between 5 minutes and an unlimited time.

If the drive has not restarted after the configured time, it will lock and the procedure is abandoned until it has been powered off and on again.

The detected faults which permit this type of restart are:

- Line overvoltage
- Motor thermal overload
- Drive thermal overload
- DC bus overvoltage
- Loss of one input phase
- External detected fault
- Loss of 4-20 mA reference
- CANopen bus detected fault
- Modbus serial link detected fault
- Line voltage too low. For this detected fault, the function is always active, even if it is not configured.

For these detected faults, the relay configured as a detected fault relay remains activated if the function is configured. The speed reference and direction of operation must be maintained for this function.

This function is suitable for machines or installations which are in continuous operation or are not monitored, and where a restart will not endanger equipment or personnel in any way.

---

#### *Derated operation in the event of an undervoltage*

---

The line voltage monitoring threshold is lowered to 50% of the motor voltage.

In this case, a line choke must be used and the performance of the drive cannot be guaranteed.

---

#### *Detected fault relay, unlocking*

---

The detected fault relay is energized when the drive is powered up and has not detected a fault.

It contains an N/C contact and an N/O contact with common point.

The drive is unlocked after a detected fault in one of the following ways:

- By powering down until the ON LED goes out, then switching the drive back on
- By assigning a logic input to the External detected faults function
- By the Automatic restart function, if it has been configured

---

#### *Resetting operating time to zero*

---

The drive operating time can be reset to zero.

## Functions (continued)

### Motor thermal protection

The theoretical temperature rise of the motor is continuously calculated to provide indirect thermal protection.

Thermal protection is adjustable from 0.2 to 1.5 times the nominal drive current.

This function is suitable for all applications with self-cooled motors.

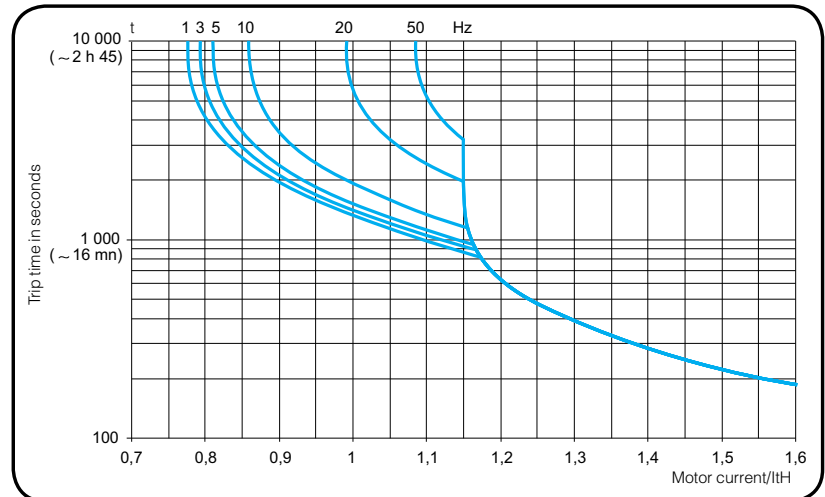

Motor thermal protection curves

### Drive thermal protection

Thermal protection, by a PTC probe mounted on the heatsink or integrated in the power module, ensures that the drive is protected in the event of poor ventilation or excessive ambient temperatures.

Locks the drive in the event of a detected fault.

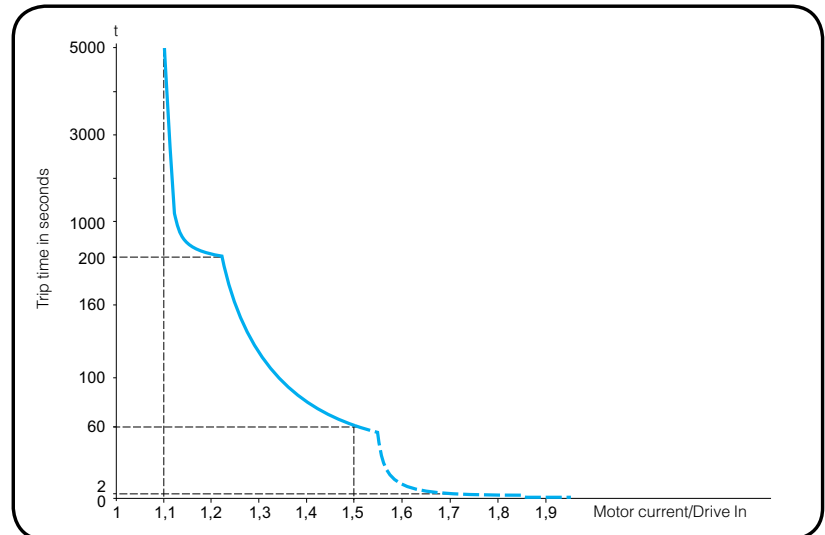

Drive thermal protection curves

### R1/R2 relay configuration

The following states are signalled when the relay is powered on:

- Drive detected fault
- Drive running
- Frequency threshold reached
- High speed reached
- Current threshold reached
- Frequency reference reached
- Motor thermal threshold reached
- Brake sequence (R2 only)



## Functions (continued)

### AOC/AOV analog outputs

The same data is available on analog outputs AOC and AOV.

The following assignments are possible:

- Motor current
- Motor frequency
- Motor torque
- Power supplied by the drive
- Drive detected fault
- Frequency threshold reached
- High speed reached
- Current threshold reached
- Frequency reference reached
- Motor thermal threshold reached
- Brake sequence

Adjusting analog outputs AOC/AOV modifies the characteristics of the current analog output AOC or the voltage analog output AOV.

AOC: can be set as 0-20 mA or 4-20 mA

AOV: can be set as 0-10 V

### Saving and retrieving the configuration

It is possible to save a configuration. This function is used to store a drive configuration in addition to the current configuration.

Retrieving this configuration clears the current configuration.

### Function compatibility table

#### Configurable I/O

Functions which are not listed in this table are fully compatible.

Stop functions have priority over run commands.

The selection of functions is limited by:

- The number of drive I/O
- The incompatibility of certain functions with one another

Functions	Summing inputs	+/- speed	Limit switch management	Preset speeds	PI regulator	Jog operation	Brake sequence	DC injection stop	Fast stop	Freewheel stop
Summing inputs		⊖		↑	⊖	↑				
+/- speed	⊖			⊖	⊖	⊖				
Limit switch management					⊖					
Preset speeds	←	⊖			⊖	↑				
PI regulator	⊖	⊖	⊖	⊖		⊖	⊖			
Jog operation	←	⊖		←	⊖		⊖			
Brake sequence					⊖	⊖		⊖		
DC injection stop							⊖			↑
Fast stop										↑
Freewheel stop							←	←		

⊖	Incompatible functions
⊖	Compatible functions
	Not applicable

#### Priority functions (functions which cannot be active at the same time)

←	The arrow indicates which function has priority
↑	Example: the Freewheel stop function has priority over the Fast stop function

### Environmental specifications

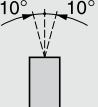
<b>Conformity to standards</b>		Altivar 312 drives have been developed to conform to the strictest international standards and the recommendations relating to electrical industrial control devices (IEC), in particular: IEC 61800-5-1 (low voltage), IEC 61800-3 (EMC immunity and conducted and radiated EMC emissions).
EMC immunity		IEC 61800-3, Environments 1 and 2 (EMC requirement and specific test methods) IEC 61000-4-2 level 3 (electrostatic discharge immunity test) IEC 61000-4-3 level 3 (radio-frequency radiated electromagnetic field immunity test) IEC 61000-4-4 level 4 (electrical fast transient/burst immunity test) IEC 61000-4-5 level 3 (surge immunity test)
Conducted and radiated EMC emissions for drives	ATV312H●●●●●	IEC 61800-3, Environments: 2 (industrial power supply) and 1 (public power supply), restricted distribution
	ATV312H018M2...HU15M2 ATV312H037N4...HU40N4	IEC 61800-3 category C2 With additional EMC filter <sup>(1)</sup> ; IEC 61800-3 category C1
	ATV312HU22M2, ATV312HU55N4...HD15N4	IEC 61800-3 category C3 With additional EMC filter <sup>(1)</sup> ; IEC 61800-3 category C2 IEC 61800-3 category C1
	ATV312H018M3...HD15M3	With additional EMC filter <sup>(1)</sup> ; IEC 61800-3 category C2
<b>CE marking</b>		The drives are marked <b>CE</b> in accordance with the European low voltage (2006/95/EC) and EMC (2004/108/EC) directives
<b>Product certification</b>		UL, CSA, NOM, GOST, C-Tick and DNV
<b>Degree of protection</b>		IP 31 and IP 41 on upper part and IP 21 on connection terminals
<b>Vibration resistance</b>	Drive not mounted on DIN rail	Conforming to IEC 60068-2-6: 1.5 mm peak to peak from 3 to 13 Hz, 1 gn from 13 to 150 Hz
<b>Shock resistance</b>		15 gn for 11 ms conforming to IEC 60068-2-27
<b>Maximum ambient pollution</b>		Degree 2 conforming to IEC 61800-5-1
<b>Definition of insulation</b>		
<b>Environmental conditions use</b>		IEC 60721-3-3 classes 3C2 and 3S2
<b>Relative humidity</b>		% 5...95% non condensing, no dripping water, conforming to IEC 60068-2-3
<b>Ambient air temperature around the device</b>	Operation	°F 14 °F...122 °F (-10 °C...+50 °C) without derating 14 °F...140 °F (-10 °C...+60 °C) with derating removing the protective cover on top of the drive
	Storage	°F -13 °F...+158 °F (-25 °C...+70 °C)
<b>Maximum operating altitude</b>	ATV312H●●●●●	ft. 3300 ft. (1000 m) without derating
	ATV312H●●●M2	ft. Up to 6600 ft. (2000 m) for single-phase supplies and corner grounded distribution networks, derating the current by 1% for each additional 330 ft. (100 m)
	ATV312H●●●M3 ATV312H●●●N4 ATV312H●●●S6	ft. Up to 9800 ft. (3000 m) for three-phase supplies, derating the current by 1% for each additional 330 ft. (100 m)
<b>Operating position</b> Maximum permanent angle in relation to the normal vertical mounting position		

<sup>(1)</sup> See table on page 49 to check the permitted cable lengths.

### Connection specifications (drive terminals for line supply, motor output, DC bus and braking resistor)

Drive terminals		L1, L2, L3, U, V, W, PC/–, PA/+, PB
<b>Maximum wire size and tightening torque</b>	ATV312H018M2...H075M2 ATV312H018M3...HU15M3	2.5 mm <sup>2</sup> (AWG 14) 0.8 Nm
	ATV312HU11M2...HU22M2 ATV312HU22M3...HU40M3 ATV312H037N4...HU40N4 ATV312H075S6...HU40S6	5 mm <sup>2</sup> (AWG 10) 1.2 Nm
	ATV312HU55M3, HU75M3 ATV312HU55N4, HU75N4 ATV312HU55S6, HU75S6	16 mm <sup>2</sup> (AWG 6) 2.5 Nm
	ATV312HD11M3, HD15M3 ATV312HD11N4, HD15N4 ATV312HD11S6, HD15S6	25 mm <sup>2</sup> (AWG 3) 4.5 Nm
<b>Electrical isolation</b>		Electrical isolation between power and control (inputs, outputs, power supplies)

### Drive specifications

<b>Output frequency range</b>		Hz	0...500 Hz
<b>Switching frequency</b>		kHz	Nominal switching frequency: 4 kHz without derating in continuous operation. Adjustable during operation from 2...16 kHz Above 4 kHz, derate the nominal drive current. The nominal motor current should not exceed this value.
<b>Speed range</b>			1...50
<b>Transient overtorque</b>			170...200% of nominal motor torque (typical value)
<b>Braking torque</b>	With braking resistor	ATV312H●●●●●	100% of nominal motor torque continuously and up to 150% for 60 s
	Without braking resistor	ATV312H018M2	150% of nominal motor torque (typical value)
		ATV312H037M2...H075M2 ATV312H018M3...H075M3 ATV312H037N4...H075N4 ATV312H075S6	100% of nominal motor torque (typical value)
		ATV312HU11M2, HU15M2 ATV312HU11M3, HU15M3 ATV312HU11N4, HU15N4 ATV312HU15S6	50% of nominal motor torque (typical value)
		ATV312HU22M2 ATV312HU22M3...HD15M3 ATV312HU22N4...HD15N4 ATV312HU22S6...HD15S6	30% of nominal motor torque (typical value)
<b>Maximum transient current</b>			150% of the nominal drive current for 60 seconds (typical value)
<b>Motor control profiles</b>			<ul style="list-style-type: none"> <li>■ Standard ratio (voltage/frequency)</li> <li>■ Performance ratio (sensorless flux vector control)</li> <li>■ Pump/fan ratio (K<sup>n</sup> quadratic ratio)</li> <li>■ Energy saving ratio (specifically for ventilation)</li> </ul>
<b>Frequency loop gains</b>			Factory-set with speed loop stability and gain Possible options for machines with high resistive torque or high inertia, or for machines with fast cycles
<b>Slip compensation</b>			Automatic whatever the load. Can be inhibited or adjusted

### Electrical Power specifications

<b>Power supply</b>	Voltage	V	200 V - 15% ... 240 V + 10% single-phase for ATV312●●●●M2 200 V - 15% ... 240 V + 10% three-phase for ATV312●●●●M3 380 V - 15% ... 500 V + 10% three-phase for ATV312●●●●N4 525 V - 15% ... 600 V + 10% three-phase for ATV312●●●●S6	
	Frequency	Hz	50...60 Hz + 5%	
<b>Prospective short-circuit current I<sub>sc</sub></b>	ATV312●●●●M2	A	≤ 1000 A (I <sub>sc</sub> at the connection point) for single-phase power supply	
	ATV312H018M3...HU40M3 ATV312H037N4...HU40N4 ATV312H075S6...HU40S6	A	≤ 5000 A (I <sub>sc</sub> at the connection point) for three-phase power supply	
	ATV312HU55M3...HD15M3 ATV312HU55N4...HD15N4 ATV312HU55S6...HD15S6	A	≤ 22000 A (I <sub>sc</sub> at the connection point) for three-phase power supply	
<b>Drive supply voltage and output voltage</b>			<b>Drive supply voltage</b>	<b>Drive output voltage for motor</b>
	ATV312H●●●M2	V	200 V...240 V single-phase	200 V...240 V three-phase
	ATV312H●●●M3	V	200 V...240 V three-phase	200 V...240 V three-phase
	ATV312H●●●N4	V	380 V...500 V three-phase	380 V...500 V three-phase
	ATV312H●●●S6	V	525 V...600 V three-phase	525 V...600 V three-phase

### I/O & Control specifications

<b>Available internal supplies</b>		Protected against short-circuits and overloads: <ul style="list-style-type: none"> <li>One 10 V c (0/+ 8%) supply for the reference potentiometer (2.2 to 10 k<math>\Omega</math>), maximum current 10 mA</li> <li>One 24 V c supply (min. 19 V, max. 30 V) for the control logic inputs, maximum current 100 mA</li> </ul>
<b>Analog inputs</b>		Sampling time < 8 ms Resolution: 10 bits Accuracy: $\pm$ 4.3% Linearity: $\pm$ 0.2% of the maximum scale value Use: <ul style="list-style-type: none"> <li>330 ft. (100 m) maximum with shielded cable</li> <li>82 ft. (25 m) maximum with unshielded cable</li> </ul>
	A11	One 0... 10 V $\overline{\text{c}}$ analog voltage input , impedance 30 k $\Omega$ , maximum voltage 30 V
	A12	One $\pm$ 10 V bipolar voltage analog input, impedance 30 k $\Omega$ , maximum voltage 30 V
	A13	One X-Y mA analog current input, X and Y programmable from 0 to 20 mA, with impedance 250 $\Omega$
<b>Analog voltage outputs or analog current outputs configurable as logic outputs</b>		2 analog outputs: <ul style="list-style-type: none"> <li>1 analog voltage output (AOV)</li> <li>1 analog current output (AOC) configurable as a logic output.</li> </ul> These 2 analog outputs cannot be used at the same time
	AOV	0...10 V $\overline{\text{c}}$ analog voltage output, min. load impedance 470 W 8-bit resolution, accuracy $\pm$ 1%, linearity $\pm$ 0.2% of the maximum scale value
	AOC	0...20 mA analog current output, max. load impedance 800 W 8-bit resolution, accuracy $\pm$ 1%, linearity $\pm$ 0.2% The AOC analog output can be configured as a 24 V logic output, max. 20 mA, min. load impedance 1.2 kW Refresh time < 8 ms
<b>Relay outputs</b>	R1A, R1B, R1C	1 relay logic output, one N/C contact and one N/O contact with common point Minimum switching capacity: 10 mA for 5 V $\overline{\text{c}}$ Maximum switching capacity: On resistive load ( $\cos \varphi = 1$ and L/R = 0 ms): 5 A for 250 V $\sim$ or 30 V $\overline{\text{c}}$ On inductive load ( $\cos \varphi = 0.4$ and L/R = 7 ms): 2 A for 250 V $\sim$ or 30 V $\overline{\text{c}}$ Sampling time < 8 ms Switching: 100,000 operations
	R2A, R2B	1 relay logic output, one N/C contact, contact open on detected fault. Minimum switching capacity: 10 mA for 5 V $\overline{\text{c}}$ Maximum switching capacity: On resistive load ( $\cos \varphi = 1$ and L/R = 0 ms): 5 A for 250 V $\sim$ or 30 V $\overline{\text{c}}$ On inductive load ( $\cos \varphi = 0.4$ and L/R = 7 ms): 2 A for 250 V $\sim$ or 30 V $\overline{\text{c}}$ Sampling time < 8 ms Switching: 100,000 operations
<b>LI logic inputs</b>	LI1...LI6	6 programmable logic inputs, compatible with PLC level 1, standard IEC/EN 61131-2 Impedance 3.5 kW 24 V $\overline{\text{c}}$ internal or 24 V $\overline{\text{c}}$ external power supply (min. 19 V, max. 30 V) Max. current: 100 mA Sampling time < 4 ms Multiple assignment makes it possible to configure several functions on one input (example: LI1 assigned to forward and preset speed 2, LI3 assigned to reverse and preset speed 3)
	Positive logic (Source)	State 0 if < 5 V or logic input not wired State 1 if > 11 V
	Negative logic (Sink)	State 0 if > 19 V or logic input not wired State 1 if < 13 V
	CLI position	Connection to PLC output
<b>Maximum I/O wire size and tightening torque</b>		2.5 mm <sup>2</sup> (AWG 14) 0.6 Nm

### I/O & Control specifications (continued)

<b>Acceleration and deceleration ramps</b>			<p>Ramp profiles:</p> <ul style="list-style-type: none"> <li>■ Linear, can be adjusted separately from 0.1 to 999.9 s</li> <li>■ S, U or customized</li> </ul> <p>Automatic adaptation of deceleration ramp time if braking capacities exceeded, possible inhibition of this adaptation (use of a braking resistor)</p>
<b>Braking to a standstill</b>			<p>By DC injection:</p> <ul style="list-style-type: none"> <li>■ By a command on a logic input (LI1 to LI6)</li> <li>■ Automatically as soon as the estimated output frequency drops to &lt; 0.5 Hz, period adjustable from 0 to 30 s or continuous, current adjustable from 0 to 1.2 In</li> </ul>
<b>Main drive protection and safety features</b>			<ul style="list-style-type: none"> <li>■ Thermal protection against overheating</li> <li>■ Protection against short-circuits between motor phases</li> <li>■ Input phase loss protection, for three-phase supply</li> <li>■ Protection against motor phase breaks</li> <li>■ Overcurrent protection between motor output phases and ground</li> <li>■ Line supply overvoltage and undervoltage safety features</li> </ul>
<b>Motor protection</b>			Thermal protection integrated in the drive by continuous calculation of the I <sup>2</sup> t
<b>Dielectric strength</b>	Between ground and power terminals	ATV312H●●●M2	2040 V ≡
		ATV312H●●●M3	
	Between control and power terminals	ATV312H●●●N4	2410 V ≡
		ATV312H●●●S6	2550 V ≡
		ATV312H●●●M2	2880 V ~
		ATV312H●●●M3	
		ATV312H●●●N4	3400 V ~
		ATV312H●●●S6	3600 V ~
<b>Signalling</b>			Display coded by one 4-digit display (messages, values) and 5 status LEDs (current mode, CANopen bus)
<b>Frequency resolution</b>	Display units	Hz	0.1
	Analog inputs	Hz	Resolution = ((high speed - low speed)/1024) Min. value = 0.1
<b>Time constant on a change of reference</b>		ms	5

## Communication Port specifications

<b>Available protocols</b>		Modbus and CANopen protocols integrated in the drive. Both these protocols can be accessed via a single RJ45 connector on the underside of the drive.
<b>Modbus protocol</b>		
<b>Structure</b>	Connector	RJ45
	Physical interface	RS 485
	Transmission mode	RTU
	Transmission speed	Configurable via the Human-Machine interface, remote display terminals or SoMove setup software: 4800, 9600 or 19200 bps
	Number of subscribers	31
	Address	1 to 247, configurable via the Human-Machine interface, remote display terminals or SoMove setup software
<b>Services</b>	Functional profiles	CiA 402
	Messaging	Read Holding Registers (03) Write Single Register (06) Write Multiple Registers (16) Read Device Identification (43)
	Communication monitoring	Configurable
<b>CANopen protocol</b>		
<b>Structure</b>	Connector	RJ45
	Network management	Slave
	Transmission speed	Configurable via the Human-Machine interface, remote display terminals or SoMove setup software: 10, 20, 50, 125, 250, 500 kbps or 1 Mbps
	Number of subscribers	127
	Address (Node ID)	1 to 127, configurable via the Human-Machine interface, remote display terminals or SoMove setup software
<b>Services</b>	Number of PDOs (Process Data Objects)	2 PDOs: <ul style="list-style-type: none"> <li>■ PDO 1: cannot be configured</li> <li>■ PDO 6: can be configured</li> </ul>
	PDO modes	PDO 1: asynchronous PDO 6: asynchronous, Sync, cyclic asynchronous
	Number of SDOs (Service Data Objects)	1 receive SDO and 1 transmit SDO
	Functional profiles	CiA 402
	Communication monitoring	Node guarding and Heartbeat, Boot-up messages, Emergency messages, Sync and NMT
<b>Diagnostics</b>	Using LEDs	On Human-Machine interface



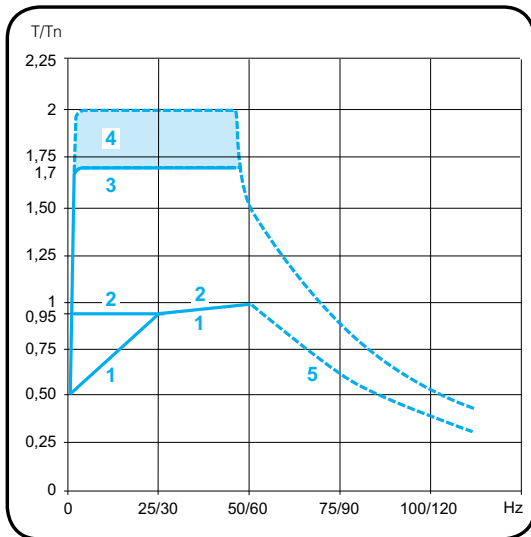

Available continuous torque and transient overtorque

## Torque specifications

The curves opposite define the available continuous torque and transient overtorque for both force-cooled and self-cooled motors. The only difference is in the ability of the motor to provide a high continuous torque at less than half the nominal speed.

- 1 Self-cooled motor: continuous useful torque <sup>(1)</sup>
- 2 Force-cooled motor: continuous useful torque
- 3 Transient overtorque for 60 s
- 4 Transient overtorque for 2 s
- 5 Torque in overspeed at constant power <sup>(2)</sup>

## Special Uses

### Use with a motor with a different power rating to that of the drive

The device can power any motor which has a lower rating than that for which the drive was designed.

For motor ratings slightly higher than that of the drive, check that the current taken does not exceed the continuous output current of the drive.

### Testing on a low power motor or without a motor

In a testing or maintenance environment the drive can be checked without having to switch to a motor with the same rating as the drive (particularly useful in the case of high power drives). This use requires deactivation of motor phase loss detection.

### Use of motors in parallel

The device can power any motor which has a lower rating than that for which the drive was designed.

For motor ratings slightly higher than that of the drive, check that the current taken does not exceed the continuous output current of the drive.

### Motor switching at the drive output

Switching can be carried out with the drive locked or unlocked. In the case of switching on-the-fly (drive unlocked), the motor is controlled and accelerated until it reaches the reference speed smoothly following the acceleration ramp. This use requires configuration of automatic catching a spinning load ("catch on the fly") and activation of the function which manages the presence of an output contactor.

Note: Depending on the drive rating, downstream ferrite suppressors may be required between the drive and the output contactor (see page 51).

Typical applications: loss of safety circuit at drive output, bypass function, switching of motors connected in parallel.

Recommendations for use: synchronize control of the output contactor with that of a freewheel stop request from the drive on a logic input.

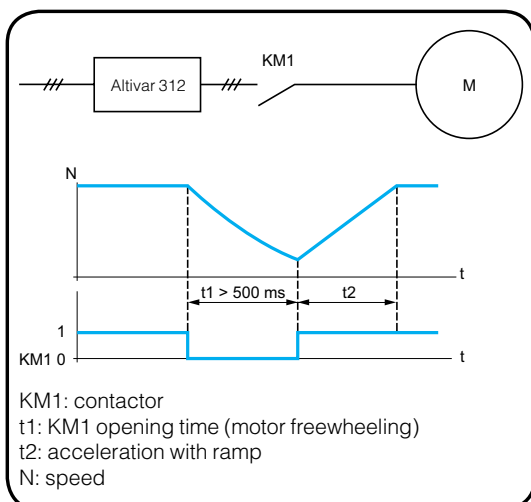

Example of loss of output contactor

(1) For power ratings  $\leq 250$  W, less derating is required (20% instead of 50% at very low frequencies).

(2) The nominal motor frequency and the maximum output frequency can be adjusted from 40 to 500 Hz. The mechanical overspeed specifications of the selected motor must be checked with the manufacturer.

## Short Circuit Current Ratings

The combinations in the tables have been tested per UL508C (Reference UL file E116875). These ratings are in addition to ratings on the nameplate of the product. The values for the overcurrent protection devices are the maximum allowable amp size. Smaller amp ratings may be used.

Integral solid state short circuit protection does not provide branch circuit protection. Branch circuit protection must be provided in accordance with the National Electrical Code and any additional local codes.

The devices are not provided with thermal protection of the motor. A sensing of motor overtemperature is required to be provided by the end user.

167°F (75°C) copper conductor with the AWG wire size shown on nameplate for all sizes.

Suitable for use on a circuit capable of delivering not more than   X   rms symmetrical kiloAmperes,   Y   Volts maximum, when protected by   Z1   with a maximum rating of   Z2  .

Altivar 312 Drive							Short Circuit Current Ratings <sup>(2)</sup>							
							with circuit breaker		with GV●P				with fuses	
Input Voltage 60 Hz	HP	kW	Part number <sup>(7)</sup>	Input rating <sup>(1)</sup> : (kA)	Minimum inductance (mH)	Line reactor part number	PowerPact	SCCR (kA) <sup>(4)</sup>	GV●P Type E <sup>(4,5)</sup>	GV●P Voltage rating (V)	GV●P Power (HP) <sup>(6)</sup>	SCCR (kA)	Fuse (A) <sup>(6)</sup>	SCCR (kA) <sup>(3,4)</sup>
Y							Z1, Z2	X	Z1, Z2				Z1, Z2	X

### Three-phase without line reactor

208/ 230 V	0.25	0.18	ATV312H018M3	5	-	-	HxL36015	5	-	-	-	-	3	22
	0.5	0.37	ATV312H037M3	5	-	-	HxL36015	5	-	-	-	-	6	22
	0.75	0.55	ATV312H055M3	5	-	-	HxL36015	5	-	-	-	-	10	22
	1	0.75	ATV312H075M3	5	-	-	HxL36015	5	-	-	-	-	10	22
	1.5	1.1	ATV312HU11M3	5	-	-	HxL36015	5	-	-	-	-	15	22
	2	1.5	ATV312HU15M3	5	-	-	HxL36015	5	-	-	-	-	15	22
	3	2.2	ATV312HU22M3	5	-	-	HxL36020	5	-	-	-	-	20	22
	-	3	ATV312HU30M3	5	-	-	HxL36020	5	-	-	-	-	25	22
	5	4	ATV312HU40M3	5	-	-	HxL36030	5	-	-	-	-	35	22
	7.5	5.5	ATV312HU55M3	22	-	-	HxL36040	22	-	-	-	-	50	22
	10	7.5	ATV312HU75M3	22	-	-	HxL36060	22	-	-	-	-	60	22
	15	11	ATV312HD11M3	22	-	-	HxL36070	22	-	-	-	-	80	22
20	15	ATV312HD15M3	22	-	-	HxL36090	22	-	-	-	-	110	22	
400/ 480 V	0.5	0.37	ATV312H037N4	5	-	-	HxL36015	5	-	-	-	-	3	5
	0.75	0.55	ATV312H055N4	5	-	-	HxL36015	5	-	-	-	-	6	5
	1	0.75	ATV312H075N4	5	-	-	HxL36015	5	-	-	-	-	6	5
	1.5	1.1	ATV312HU11N4	5	-	-	HxL36015	5	-	-	-	-	10	5
	2	1.5	ATV312HU15N4	5	-	-	HxL36015	5	-	-	-	-	10	5
	3	2.2	ATV312HU22N4	5	-	-	HxL36015	5	-	-	-	-	15	5
	-	3	ATV312HU30N4	5	-	-	HxL36015	5	-	-	-	-	15	5
	5	4	ATV312HU40N4	5	-	-	HxL36015	5	-	-	-	-	20	5
	7.5	5.5	ATV312HU55N4	22	-	-	HxL36020	22	-	-	-	-	30	22
	10	7.5	ATV312HU75N4	22	-	-	HxL36030	22	-	-	-	-	35	22
	15	11	ATV312HD11N4	22	-	-	HxL36035	22	-	-	-	-	50	22
	20	15	ATV312HD15N4	22	-	-	HxL36050	22	-	-	-	-	70	22

\*footnotes on page 31.

# Altivar 312

## variable speed drives

# Short Circuit Current Ratings

## Short Circuit Current Ratings

Altivar 312 Drive							Short Circuit Current Ratings <sup>(2)</sup>							
							with circuit breaker		with GV●P				with fuses	
Input Voltage 60 Hz	HP	kW	Part number <sup>(7)</sup>	Input rating <sup>(1)</sup> : (kA)	Minimum inductance (mH)	Line reactor part number	PowerPact	SCCR (kA) <sup>(4)</sup>	GV●P Type E <sup>(4,5)</sup>	GV●P Voltage rating (V)	GV●P Power (HP) <sup>(8)</sup>	SCCR (kA)	Fuse (A) <sup>(6)</sup>	SCCR (kA) <sup>(3,4)</sup>
Y							Z1, Z2	X	Z1, Z2				Z1, Z2	X
<b>Three-phase with line reactor</b>														
208/ 230 V	0.25	0.18	ATV312H018M3	5	3	RL-00401	HxL36015	65	-	-	-	65	3	22
	0.5	0.37	ATV312H037M3	5	3	RL-00401	HxL36015	65	-	-	-	65	6	22
	0.75	0.55	ATV312H055M3	5	3	RL-00401	HxL36015	65	-	-	-	65	10	22
	1	0.75	ATV312H075M3	5	3	RL-00401	HxL36015	65	-	-	-	65	10	22
	1.5	1.1	ATV312HU11M3	5	1.5	RL-00801	HxL36015	65	GV2P14	240	3	65	15	22
	2	1.5	ATV312HU15M3	5	1.5	RL-00801	HxL36015	65	GV2P14	240	3	65	15	22
	3	2.2	ATV312HU22M3	5	1.25	RL-01201	HxL36020	65	GV3P18/13	240	5/3	65	20	22
	-	3	ATV312HU30M3	5	1.25	RL-01801	HxL36020	65	GV3P18	240	5	65	25	22
	5	4	ATV312HU40M3	5	1.25	RL-01801	HxL36030	65	GV3P25	240	7.5	65	35	22
	7.5	5.5	ATV312HU55M3	22	0.5	RL-02501	HxL36040	65	GV3P40/32	240	10/7.5	65	50	22
	10	7.5	ATV312HU75M3	22	0.4	RL-03501	HxL36060	65	GV3P50	240	10	65	60	22
	15	11	ATV312HD11M3	22	0.3	RL-04501	HxL36070	65	GV3P65	240	15	65	80	22
20	15	ATV312HD15M3	22	0.2	RL-08001	HxL36090	65	-	-	-	-	110	22	
400/ 480 V	0.5	0.37	ATV312H037N4	5	12	RL00201	HxL36015	65	GV2P07	480Y/277	1	65	3	100
	0.75	0.55	ATV312H055N4	5	12	RL00201	HxL36015	65	GV2P07	480Y/277	1	65	6	100
	1	0.75	ATV312H075N4	5	12	RL00201	HxL36015	65	GV2P08	480Y/277	2	65	6	100
	1.5	1.1	ATV312HU11N4	5	6.5	RL00402	HxL36015	65	GV2P08	480Y/277	2	65	10	100
	2	1.5	ATV312HU15N4	5	6.5	RL00402	HxL36015	65	GV2P10	480Y/277	3	65	10	100
	3	2.2	ATV312HU22N4	5	5	RL00803	HxL36015	65	GV2P14	480Y/277	5	65	15	100
	-	3	ATV312HU30N4	5	3	RL00802	HxL36015	65	GV2P14	480Y/277	5	65	15	100
	5	4	ATV312HU40N4	5	3	RL00802	HxL36015	65	GV3P13	480Y/277	7.5	65	20	100
	7.5	5.5	ATV312HU55N4	22	2.5	RL01202	HxL36020	65	GV3P18	480Y/277	7.5	65	30	100
	10	7.5	ATV312HU75N4	22	1.5	RL01802	HxL36030	65	GV3P25	480Y/277	15	65	35	100
	15	11	ATV312HD11N4	22	1.2	RL02502	HxL36035	65	GV3P32	480Y/277	20	65	50	100
20	15	ATV312HD15N4	22	0.8	RL03502	HxL36050	65	GV3P40	480Y/277	25	65	70	100	
575/ 600 V	1	0.75	ATV312H075S6	5	20	RL-00202	-	-	-	-	-	-	6	22
	2	1.5	ATV312HU15S6	5	9	RL-00403	-	-	-	-	-	-	6	22
	3	2.2	ATV312HU22S6	5	6.5	RL-00402	-	-	-	-	-	-	10	22
	5	4	ATV312HU40S6	5	5	RL-00803	-	-	-	-	-	-	15	22
	7.5	5.5	ATV312HU55S6	22	2.5	RL-01202	-	-	-	-	-	-	20	22
	10	7.5	ATV312HU75S6	22	2.5	RL-01202	-	-	-	-	-	-	25	22
	15	11	ATV312HD11S6	22	1.5	RL-01802	-	-	-	-	-	-	35	22
	20	15	ATV312HD15S6	22	1.2	RL-02502	-	-	-	-	-	-	45	22

\*footnotes on page 31.

## Short Circuit Current Ratings

Altivar 312 Drive							Short Circuit Current Ratings <sup>(2)</sup>							
							with circuit breaker		with GV●P				with fuses	
Input Voltage 60 Hz	HP	kW	Part number <sup>(7)</sup>	Input rating <sup>(1)</sup> : (kA)	Minimum inductance (mH)	Line reactor part number	PowerPact	SCCR (kA) <sup>(4)</sup>	GV●P Type E <sup>(4,5)</sup>	GV●P Voltage rating (V)	GV●P Power (HP) <sup>(6)</sup>	SCCR (kA)	Fuse (A) <sup>(6)</sup>	SCCR (kA) <sup>(3,4)</sup>
Y							Z1, Z2	X	Z1, Z2				Z1, Z2	X

### Single-phase without line reactor

208/ 230 V	0.25	0.18	ATV312H018M2	1	-	-	-	-	-	-	-	-	6	22
	0.5	0.37	ATV312H037M2	1	-	-	-	-	-	-	-	-	10	22
	0.75	0.55	ATV312H055M2	1	-	-	-	-	-	-	-	-	10	22
	1	0.75	ATV312H075M2	1	-	-	-	-	-	-	-	-	15	22
	1.5	1.1	ATV312HU11M2	1	-	-	-	-	-	-	-	-	20	22
	2	1.5	ATV312HU15M2	1	-	-	-	-	-	-	-	-	20	22
	3	2.2	ATV312HU22M2	1	-	-	-	-	-	-	-	-	30	22
	5	4	ATV312HU75M3	2	-	-	-	-	-	-	-	-	60	22
	7.5	5.5	ATV312HD11M3	2	-	-	-	-	-	-	-	-	80	22
10	7.5	ATV312HD15M3	2	-	-	-	-	-	-	-	-	110	22	
400/ 480 V	0.5	0.37	ATV312H075N4	5	-	-	-	-	-	-	-	-	6	5
	0.75	0.55	ATV312HU11N4	5	-	-	-	-	-	-	-	-	10	5
	1	0.75	ATV312HU15N4	5	-	-	-	-	-	-	-	-	10	5
	1.5	1.1	ATV312HU22N4	5	-	-	-	-	-	-	-	-	15	5
	2	1.5	ATV312HU30N4	5	-	-	-	-	-	-	-	-	15	5
	3	2.2	ATV312HU40N4	5	-	-	-	-	-	-	-	-	20	5
	3	2.2	ATV312HU55N4	22	-	-	-	-	-	-	-	-	30	22
	5	4	ATV312HU75N4	22	-	-	-	-	-	-	-	-	35	22
	7.5	5.5	ATV312HD11N4	22	-	-	-	-	-	-	-	-	50	22
10	7.5	ATV312HD15N4	22	-	-	-	-	-	-	-	-	70	22	

### Single-phase with line reactor

208/ 230 V	5	4	ATV312HU75M3	22	0.75	RL-03502	-	-	-	-	-	-	60	22
	7.5	5.5	ATV312HD11M3	22	0.375	RL-05502	-	-	-	-	-	-	80	22
	10	7.5	ATV312HD15M3	22	0.278	RL-08002	-	-	-	-	-	-	110	22
400/ 480 V	0.5	0.37	ATV312H075N4	5	5.79	RL-00402	-	-	-	-	-	-	6	22
	0.75	0.55	ATV312HU11N4	5	4.27	RL-00402	-	-	-	-	-	-	10	22
	1	0.75	ATV312HU15N4	5	4.27	RL-00803	-	-	-	-	-	-	10	22
	1.5	1.1	ATV312HU22N4	5	2.77	RL-00802	-	-	-	-	-	-	15	22
	2	1.5	ATV312HU30N4	5	2.77	RL-00802	-	-	-	-	-	-	15	22
	3	2.2	ATV312HU40N4	5	1.68	RL-01202	-	-	-	-	-	-	20	22
	3	2.2	ATV312HU55N4	22	1.29	RL-01802	-	-	-	-	-	-	30	22
	5	4	ATV312HU75N4	22	0.912	RL-02502	-	-	-	-	-	-	35	22
	7.5	5.5	ATV312HD11N4	22	0.694	RL-03502	-	-	-	-	-	-	50	22
10	7.5	ATV312HD15N4	22	0.569	RL-04502	-	-	-	-	-	-	70	22	

<sup>1</sup>footnotes on page 31.

---

## Short Circuit Current Ratings

---

- (1) This column shows the maximum prospective short-circuit current value for which these Altivar 312 drives can be installed on without adding impedance. Electrical distribution systems with a higher prospective short-circuit current will cause higher input currents in the front end of the drive.  
Add inductance referred to in the table at the input of the drive if installing the drive on a system with higher prospective short-circuit current. A 3% (minimum) input line reactor or equivalent inductance is required for the 500/600 Vac Altivar 312 drives and provides the listed value with the listed fuse protection.
- (2) An output short-circuit test was performed for 100 kA. In addition to this test, a breakdown of components test was performed by shorting components internal to the drive. These ratings allow proper coordination of short-circuit protection.
- (3) Ratings also apply to ATV312 Type 1 product, i.e.: an ATV312 fitted with a conduit box.
- (4) Ratings apply to an ATV312 mounted in a non-ventilated Type 1, 3R, 4(X) or 12 rated enclosure. Minimum enclosure volume is 3.375 times the drive volume.
- (5) 480Y/277V ratings are for Wye connected electrical distribution systems only. GV2P●● self protected manual combination starter must be used with GV2GH7 insulating barrier to meet UL 508 Type E rating. GV3P●● must be used with GV3G66 and GVAM11 in order to meet UL508 Type E rating.
- (6) Fuse type: Class J, can be fast acting or time delay, or Class CC.
- (7) Available also for B products. Example: ATV312H018M3B
- (8) UL508C Par. 57.1 requires publishing the standard Type E combination motor controller power rating since this is a basic identification marking of the Type E devices. However, when applied as an input overcurrent protective device for a drive, the rated current of the Type E combination motor controller, not the rated power, is the key parameter for dimensioning (reference UL508C paragraph 45.8.11 and 45.8.12). Schneider Electric GV●P Type E combination motor controllers are adjustable, their current range is shown on the adjustment dial and their selection is based on the input current and not power rating of the drive.

# Altivar 312

## variable speed drives

# Selection Table

### Selection Table

Motor		Line supply				Altivar 312			Part numbers	Weight		
Power indicated on rating plate <sup>(1)</sup>	HP	kW	Max. line current <sup>(2),(3)</sup>		Apparent power at U2	Max. prospective line Isc <sup>(4)</sup>	Max. continuous output current (In) <sup>(1)</sup>	Max. transient current for 60 s		Power dissipated at maximum output current (In) <sup>(1)</sup>	lbs	kg
			at U1	at U2					at U2			
			A	A	kVA	kA	A	A	W			
<b>Single-phase supply voltage: 200...240 V 50/60 Hz, with integrated EMC filter <sup>(3),(5),(6)</sup></b>												
0.25	0.18		3.0	2.5	0.6	1	1.5	2.3	24	ATV312H018M2	2.0	1.5
0.5	0.37		5.3	4.4	1	1	3.3	5	41	ATV312H037M2	2.0	1.5
0.75	0.55		6.8	5.8	1.4	1	3.7	5.6	46	ATV312H055M2	2.0	1.5
1	0.75		8.9	7.5	1.8	1	4.8	7.2	60	ATV312H075M2	2.0	1.5
1.5	1.1		12.1	10.2	2.4	1	6.9	10.4	74	ATV312HU11M2	2.4	1.8
2	1.5		15.8	13.3	3.2	1	8	12	90	ATV312HU15M2	2.4	1.8
3	2.2		21.9	18.4	4.4	1	11	16.5	123	ATV312HU22M2	4.2	3.1
<b>Three-phase supply voltage: 200...240 V 50/60 Hz, without EMC filter <sup>(3),(7)</sup></b>												
0.25	0.18		2.1	1.9	0.7	5	1.5	2.3	23	ATV312H018M3	1.7	1.3
0.5	0.37		3.8	3.3	1.3	5	3.3	5	38	ATV312H037M3	1.7	1.3
0.75	0.55		4.9	4.2	1.7	5	3.7	5.6	43	ATV312H055M3	1.7	1.3
1	0.75		6.4	5.6	2.2	5	4.8	7.2	55	ATV312H075M3	1.7	1.3
1.5	1.1		8.5	7.4	3	5	6.9	10.4	71	ATV312HU11M3	2.3	1.7
2	1.5		11.1	9.6	3.8	5	8	12	86	ATV312HU15M3	2.3	1.7
3	2.2		14.9	13	5.2	5	11	16.5	114	ATV312HU22M3	2.3	1.7
-	3		19.1	16.6	6.6	5	13.7	20.6	146	ATV312HU30M3	3.9	2.9
5	4		24.2	21.1	8.4	5	17.5	26.3	180	ATV312HU40M3	3.9	2.9
7.5	5.5		36.8	32	12.8	22	27.5	41.3	292	ATV312HU55M3	8.6	6.4
10	7.5		46.8	40.9	16.2	22	33	49.5	388	ATV312HU75M3	8.6	6.4
15	11		63.5	55.6	22	22	54	81	477	ATV312HD11M3	14.1	10.5
20	15		82.1	71.9	28.5	22	66	99	628	ATV312HD15M3	14.1	10.5
<b>Three-phase supply voltage: 380...500 V 50/60 Hz, with integrated EMC filter <sup>(3),(5),(6)</sup></b>												
0.5	0.37		2.2	1.7	1.5	5	1.5	2.3	32	ATV312H037N4	2.4	1.8
0.75	0.55		2.8	2.2	1.8	5	1.9	2.9	37	ATV312H055N4	2.4	1.8
1	0.75		3.6	2.7	2.4	5	2.3	3.5	41	ATV312H075N4	2.4	1.8
1.5	1.1		4.9	3.7	3.2	5	3	4.5	48	ATV312HU11N4	2.4	1.8
2	1.5		6.4	4.8	4.2	5	4.1	6.2	61	ATV312HU15N4	2.4	1.8
3	2.2		8.9	6.7	5.9	5	5.5	8.3	79	ATV312HU22N4	4.2	3.1
-	3		10.9	8.3	7.1	5	7.1	10.7	125	ATV312HU30N4	4.2	3.1
5	4		13.9	10.6	9.2	5	9.5	14.3	150	ATV312HU40N4	4.2	3.1
7.5	5.5		21.9	16.5	15	22	14.3	21.5	232	ATV312HU55N4	8.7	6.5
10	7.5		27.7	21	18	22	17	25.5	269	ATV312HU75N4	8.7	6.5
15	11		37.2	28.4	25	22	27.7	41.6	397	ATV312HD11N4	14.8	11
20	15		48.2	36.8	32	22	33	49.5	492	ATV312HD15N4	14.8	11
<b>Three-phase supply voltage: 525...600 V 50/60 Hz, without EMC filter <sup>(3),(8)</sup></b>												
1	0.75		2.8	2.4	2.5	5	1.7	2.6	36	ATV312H075S6	2.3	1.7
2	1.5		4.8	4.2	4.4	5	2.7	4.1	48	ATV312HU15S6	2.3	1.7
3	2.2		6.4	5.6	5.8	5	3.9	5.9	62	ATV312HU22S6	3.9	2.9
5	4		10.7	9.3	9.7	5	6.1	9.2	94	ATV312HU40S6	3.9	2.9
7.5	5.5		16.2	14.1	15	22	9	13.5	133	ATV312HU55S6	8.3	6.2
10	7.5		21.3	18.5	19	22	11	16.5	165	ATV312HU75S6	8.3	6.2
15	11		27.8	24.4	25	22	17	25.5	257	ATV312HD11S6	13.4	10
20	15		36.4	31.8	33	22	22	33	335	ATV312HD15S6	13.4	10

(1) These values are given for a nominal switching frequency of 4 kHz, for use in continuous operation. The switching frequency is adjustable from 2 to 16 kHz. Above 4 kHz, derate the nominal drive current. The nominal motor current should not exceed this value. See derating curves on page 54.

(2) Typical value for a 4-pole motor and a maximum switching frequency of 4 kHz, with no line choke for max. prospective line Isc (4).

(3) Nominal supply voltage, min. U1, max. U2: 200 (U1)...240 V (U2), 380 (U1)...500 V (U2), 525 (U1)...600 V (U2).

(4) If line Isc is greater than the values in the table, add line chokes (see page 47).

(5) Drives supplied with category C2 or C3 integrated EMC filter. This filter can be disconnected.

(6) If a communication card is used, it takes the place of the control I/O card. To reduce installation costs, the drive can be ordered without a control I/O card. To do this, simply add a B at the end of the reference. For example: ATV312H075N4 becomes ATV312H075N4B. The communication card must be ordered separately (see page 36).

(7) EMC filter available as an option (see page 49).

(8) Mandatory line choke to be ordered separately (see page 47).



ATV312H037M2



ATV312HU15N4



ATV312HU30N4



ATV312HU75N4



# Altivar 312 variable speed drives

## Dimensions

*ATV312H018M2...H075M2, ATV312H018M3...H075M3*

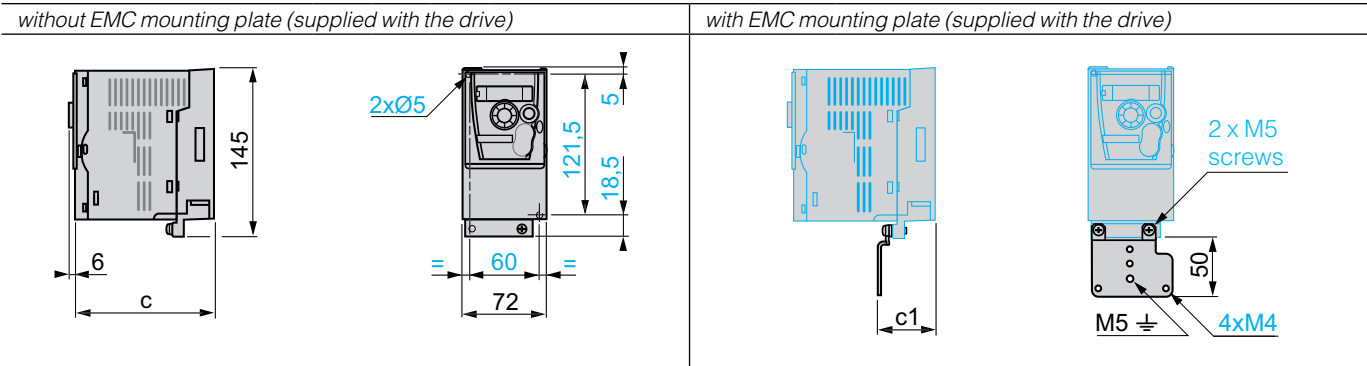

ATV312 unit	c	c1
H018M2, H037M2	132	61.5
H055M2, H075M2	142	61.5
H018M3, H037M3	122	51.5
H055M3, H075M3	132	51.5

*ATV312HU11M2...HU22M2, ATV312HU11M3...HU40M3, ATV312H037N4...HU40N4, ATV312H075S6...HU40S6*

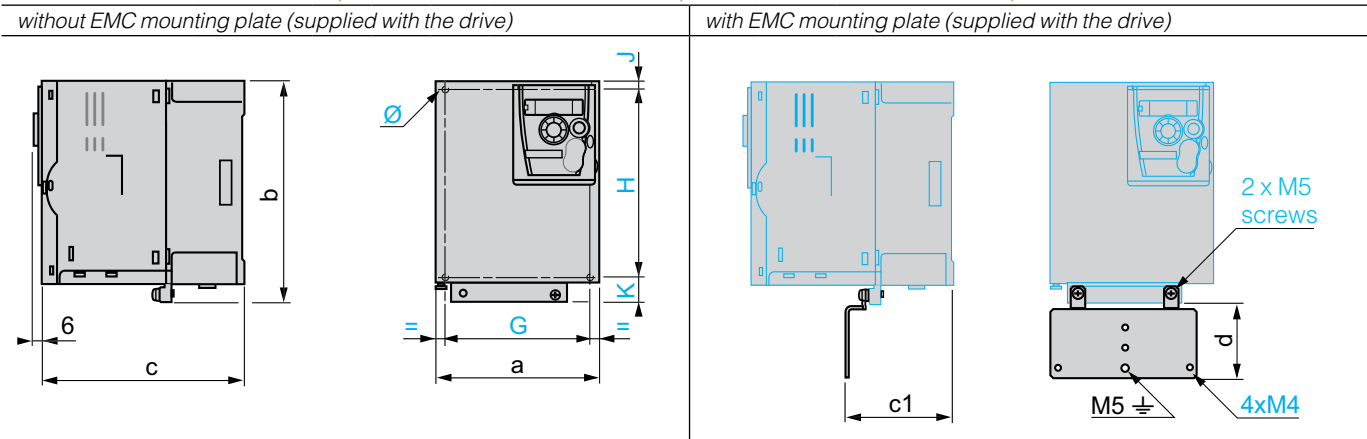

ATV312 unit	a	b	c	d	G	H	J	K	Ø
HU11M3, HU15M3	105	143	132	49	93	121.5	5	16.5	2xØ5
HU11M2, HU15M2	107	143	152	49	93	121.5	5	16.5	2xØ5
HU22M3 H037N4...HU15N4 H075S6, HU15S6	142	184	152	48	126	157	6.5	20.5	4xØ5
HU22M2 HU30M3, HU40M3 HU22N4...HU40N4 HU22S6, HU40S6									

# Altivar 312

## variable speed drives

## Dimensions

*ATV312HU55M3, HU75M3, ATV312HU55N4, HU75N4, ATV312HU55S6, HU75S6*

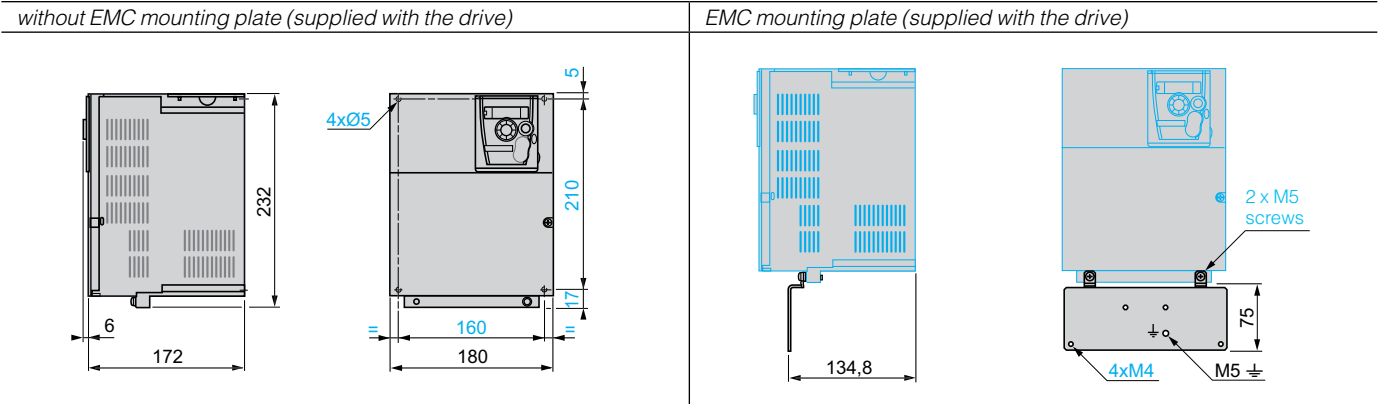

*ATV312HD11M3, HD15M3, ATV312HD11N4, HD15N4, ATV312HD11S6, HD15S6*

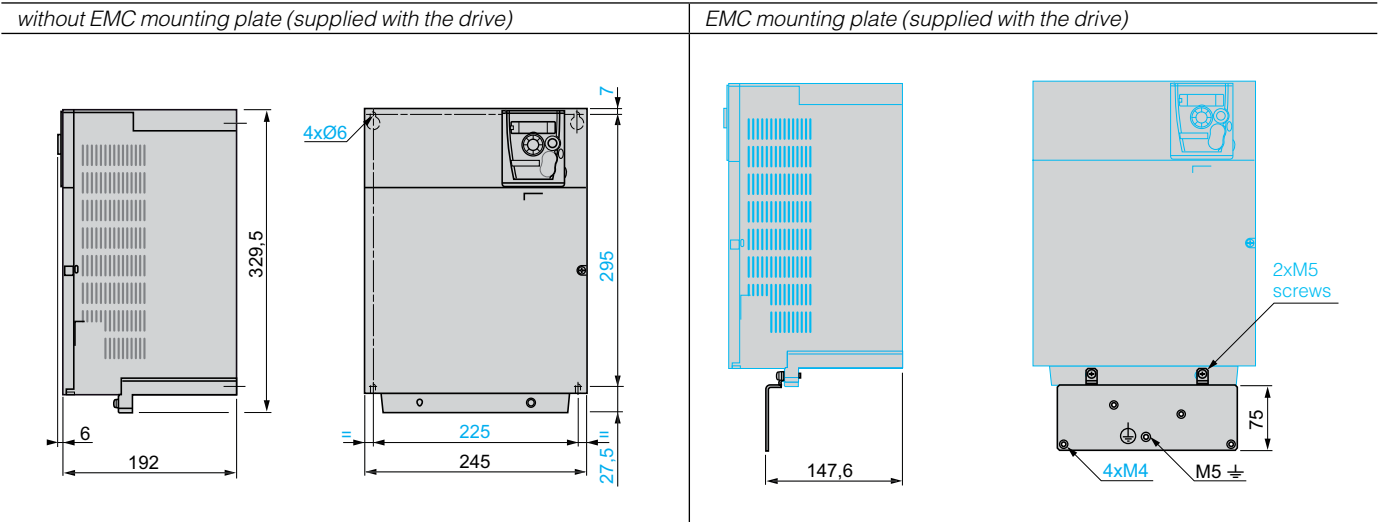



Plate for mounting on DIN rail

### Accessories

Description	For drives	Sold in lots of	Part numbers	Weight	
				lbs	kg
<b>Plates for mounting on DIN rail</b> width 35 mm	ATV312H018M2...H075M2 ATV312H018M3...H075M3	-	<b>VW3A9804</b>	0.64	0.29
	ATV312HU11M2, HU15M2 ATV312HU11M3...HU22M3 ATV312H037N4...HU15N4 ATV312H075S6, HU15S6	-	<b>VW3A9805</b>	0.85	0.39
	ATV312H018M2...H075M2 ATV312H018M3...H075M3 ATV312HU11M3, HU15M3	-	<b>VW3A31812</b> <b>VW3A31811</b> <b>VW3A31813</b>	0.88	0.40
	ATV312HU11M2, HU15M2 ATV312HU22M3 ATV312H037N4...HU15N4 ATV312H075S6, HU15S6	-	<b>VW3A31814</b>	1.10	0.50
<b>UL Type 1 conformity kits</b> Mechanical device for mounting to the lower part of the drive. For direct connection of cables to the drive via tubes or cable glands	ATV312HU22M2 ATV312HU30M3, HU40M3 ATV312HU22N4...HU40N4 ATV312HU22S6, HU40S6	-	<b>VW3A31815</b>	1.10	0.50
	ATV312HU55M3, HU75M3 ATV312HU55N4, HU75N4 ATV312HU55S6, HU75S6	-	<b>VW3A31816</b>	1.98	0.90
	ATV312HD11M3, HD15M3 ATV312HD11N4, HD15N4 ATV312HD11S6, HD15S6	-	<b>VW3A31817</b>	2.65	1.20
	ATV312H●●●●●	25	<b>TM200RSRCEMC</b>	-	-

### Replacement parts



Replacement fan (VZ3V3101)

Description	For drives	Part numbers	Weight	
			lbs	kg
<b>ATV312 control I/O card</b>	ATV312H●●●●●	<b>VW3A31201</b>	0.44	0.20
<b>Fans</b>	ATV312HU11M2, HU15M2 ATV312HU11M3, HU22M3 ATV312H037N4, HU15N4 ATV312H075S6, HU15S6	<b>VZ3V3101</b>	0.44	0.20
	ATV312HU22M2 ATV312HU30M3, HU40M3 ATV312HU22N4, HU40N4 ATV312HU22S6, HU40S6	<b>VZ3V3102</b>	0.44	0.20
	ATV312HU55M3, HU75M3 ATV312HU55N4, HU75N4 ATV312HU55S6, HU75S6	<b>VZ3V3103</b>	0.44	0.20
	ATV312HD11M3, HD15M3 ATV312HD11N4, HD15N4 ATV312HD11S6, HD15S6	<b>VZ3V3104</b>	0.66	0.30



### Communication Buses & Networks

The Altivar 312 drive is designed to meet the configuration requirements found in the main industrial communication installations.

It includes the Modbus and CANopen communication protocols as standard. It can also be connected to other industrial communication buses and networks using one of the communication cards or modules that are available as options.

#### Standard configuration

The Altivar 312 drive is equipped with a control I/O card 1 which integrates:

- I/O terminals, comprising:
  - Six logic inputs: LI1 to LI6
  - Three analog inputs: AI1 to AI3
  - Two analog outputs: AOV and AOC <sup>(1)</sup>
  - Two relay outputs: R1 and R2
- A Modbus/CANopen communication port, that is accessed on an RJ45 connector

The Modbus/CANopen communication port is specifically for controlling the drive via a PLC or another type of controller.

It is also used for connecting dialogue and configuration tools:

- Remote display terminal
- Remote graphic display terminal
- SoMove setup software
- Simple Loader and Multi-Loader configuration tools

#### Communication cards for industrial applications

Several communication cards for industrial applications 2 are available as options. These cards are used in place of the drive's control I/O card 1

The following communication cards are available:

- CANopen Daisy chain card (optimized solution for daisy chain connection to CANopen machine bus, see page 40)
- DeviceNet card
- PROFIBUS DP card

#### Communication modules

The Altivar 312 drive can be connected to other communication buses and networks via modules that are available as options:

- Modbus TCP network via the Ethernet/Modbus bridge
- Fipio bus via the Fipio/Modbus gateway

<sup>(1)</sup> These two outputs cannot be used at the same time.

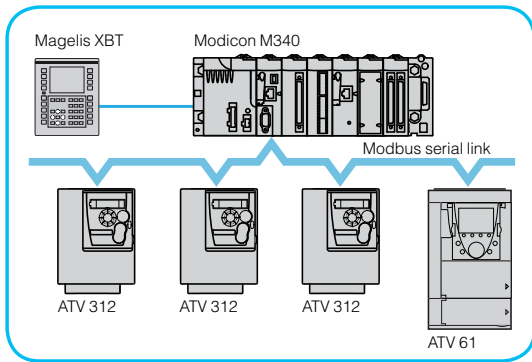

Example of configuration on Modbus serial link

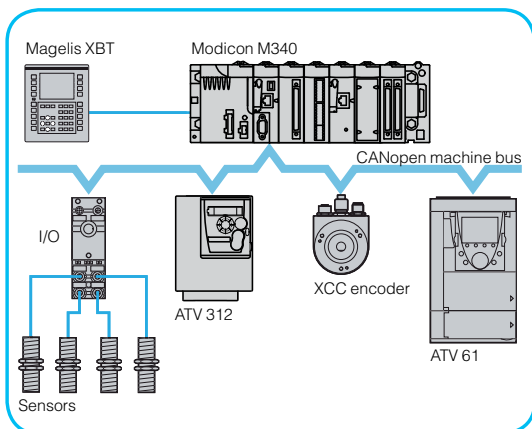

Example of configuration on CANopen machine bus

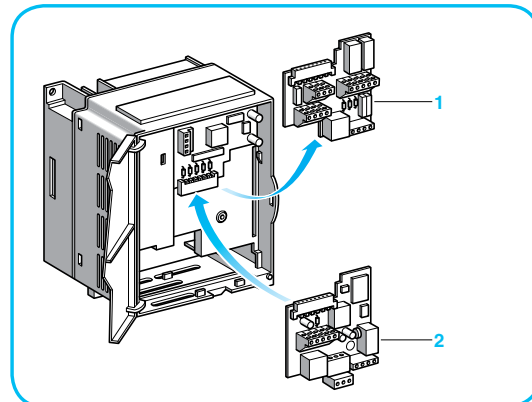

Example of installation of a communication card

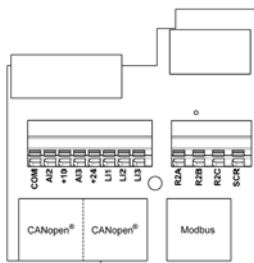

CANopen Daisy Chain card (VW3A31208)



DeviceNet card (VW3A31209)

## Communication buses and networks

### Functions

All the functions of the Altivar 312 drive can be accessed via the communication buses and networks:

- Control
- Monitoring
- Adjustment
- Configuration

The speed control and reference may come from different control sources:

- Logic input or analog I/O terminals
- Communication bus or network
- Remote display terminal

The advanced functions of the Altivar 312 drive can be used to manage switching of these control sources according to the requirements of the application.

The assignment of the communication periodic I/O data can be selected using the network configuration software.

The Altivar 312 drive is controlled using the CiA 402 native profile.

Communication is monitored according to criteria specific to each protocol.

Regardless of protocol type, the reaction of the drive to a communication detected fault can be configured as follows:

- Freewheel stop, stop on ramp, fast stop or braked stop
- Maintain the last command received
- Fallback position at a predefined speed
- Ignore the detected fault

## Characteristics of the CANopen Daisy Chain card VW3A31208 <sup>(1)</sup>

<b>Structure</b>	Connector	4 connectors: <ul style="list-style-type: none"> <li>■ 1 removable screw terminal block:                         <ul style="list-style-type: none"> <li>□ 3 logic inputs: LI1 to LI3</li> <li>□ 2 analog inputs: AI2 and AI3</li> <li>□ 1 relay output: R2</li> </ul> </li> <li>■ 2 RJ45 connectors for daisy-chain connection to the CANopen machine bus</li> <li>■ 1 RJ45 connector for connection to the Modbus serial link</li> </ul>
------------------	-----------	---

(1) The other characteristics of the CANopen Daisy chain card are identical to those of the drive's CANopen protocol. See page 40.

## Characteristics of the DeviceNet card VW3A31209

<b>Structure</b>	Connector	3 connectors: <ul style="list-style-type: none"> <li>■ 1 removable screw terminal block:                         <ul style="list-style-type: none"> <li>□ 3 logic inputs: LI1 to LI3</li> <li>□ 2 analog inputs: AI2 and AI3</li> <li>□ 1 relay output: R2.</li> </ul> </li> <li>■ 1 five-way screw connector, 5.08 pitch, for connection to the DeviceNet network</li> <li>■ 1 RJ45 connector for connection to the Modbus serial link</li> </ul>
	Transmission speed	125 kbps, 250 kbps or 500 kbps, configurable using switches on the card
	Address	1 to 63, configurable using switches on the card
<b>Services</b>	Periodic variables	ODVA AC drive type profile 20, 21, 70 and 71 ATV 312 native profile (CiA 402) 100 and 101
	Exchange mode	Inputs: by polling, change of state, periodic Outputs: by polling
	Auto Device Replacement	No
	Communication monitoring	Can be inhibited Time out can be set via the DeviceNet network configurator
<b>Diagnostics</b>	Using LEDs	One two-tone LED on the card: "MNS" (status)

## Communication buses and networks

### Characteristics of the PROFIBUS DP card VW3A31207

<b>Structure</b>	Connector	3 connectors: <ul style="list-style-type: none"> <li>■ 1 removable screw terminal block: <ul style="list-style-type: none"> <li>□ 3 logic inputs: L11 to L13</li> <li>□ 2 analog inputs: AI2 and AI3</li> <li>□ 1 relay output: R2.</li> </ul> </li> <li>■ 1 screw terminal block for connection to the PROFIBUS DP bus</li> <li>■ 1 RJ45 connector for connection to the Modbus serial link</li> </ul>
	Transmission speed	9600 bps, 19.2 kbps, 93.75 kbps, 187.5 kbps, 500 kbps, 1.5 Mbps, 3 Mbps, 6 Mbps or 12 Mbps
	Address	1 to 126, configurable using switches on the card
<b>Services</b>	Periodic variables	Input: 4 PKW and 2 PZD Output: 4 PKW and 2 PZD
	Messaging	Via PKW periodic variables
	Functional profile	IEC 61800-7 (CiA 402)
<b>Diagnostics</b>	Using LEDs	2 LEDs on the card: "ST" (status) and "DX" (data exchange)



PROFIBUS DP card  
(VW3A31207)

### Communication card part numbers <sup>(1)</sup>

Description	Part numbers	Weight	
		lbs	kg
<b>CANopen Daisy chain communication card</b> for daisy chaining (see page 40)	<b>VW3A31208</b>	0.44	0.20
<b>DeviceNet communication card</b>	<b>VW3A31209</b>	0.44	0.20
<b>PROFIBUS DP communication card</b>	<b>VW3A31207</b>	0.44	0.20

<sup>(1)</sup> To reduce installation costs when replacing the control I/O card with a communication card, ATV312H●●●M2 and ATV312H●●●N4 drives can be ordered without a control I/O card. See page 32.

### Communication buses and networks

#### Modbus serial link

##### Accessories for connection via splitter boxes and RJ45 connectors

Description	Item no.	Length		Part numbers	Weight	
		ft	m		lbs	kg
<b>Modbus splitter box</b> 10 RJ45 connectors and 1 screw terminal block	<b>1</b>	-	-	<b>LU9GC3</b>	1.10	0.50
<b>Cables for Modbus serial link</b> equipped with 2 RJ45 connectors	<b>2</b>	0.98	0.3	<b>VW3A8306R03</b>	0.06	0.025
		3.28	1	<b>VW3A8306R10</b>	0.13	0.06
		9.84	3	<b>VW3A8306R30</b>	0.29	0.13
<b>Modbus T-connectors</b> (with integrated cable)	<b>3</b>	0.98	0.3	<b>VW3A8306TF03</b>	-	-
		3.28	1	<b>VW3A8306TF10</b>	-	-
<b>Modbus line terminators</b> for RJ45 connector <sup>(3) (4)</sup>	R = 120 Ω <b>4</b>	-	-	<b>VW3A8306RC</b>	0.44	0.20
	C = 1 nF <b>4</b>	-	-	<b>VW3A8306R</b>	0.44	0.20

##### Accessories for connection via tap junctions

Description	Item no.	Length		Part numbers	Weight	
		ft	m		lbs	kg
<b>Modbus subscriber socket</b> Two 15-way female SUB-D connectors and 2 screw terminal blocks, RC line terminator To be connected using cable VW3A8306	<b>5</b>	-	-	<b>TSXSACA62</b>	1.26	0.57
<b>Modbus junction box</b> 3 screw terminal blocks, RC line terminator To be connected using cable VW3A8306D30	<b>6</b>	-	-	<b>TSXSACA50</b>	1.15	0.52
<b>RS 485 double shielded twisted pair Modbus cables</b> Supplied without connector	<b>7</b>	328.08	100	<b>TSXCASA100</b>	-	-
		656.17	200	<b>TSXCASA200</b>	-	-
		1640.4	500	<b>TSXCASA500</b>	-	-
<b>Modbus drop cable</b> 1 RJ45 connector and 1 x 15-way male SUB-D connector for TSXSACA62	<b>8</b>	9.84	3	<b>VW3A8306</b>	0.33	0.15
<b>Modbus drop cable</b> 1 RJ45 connector and one stripped end	<b>9</b>	9.84	3	<b>VW3A8306D30</b>	0.33	0.15
<b>Modbus line terminators</b> for screw terminal block <sup>(3) (4)</sup>	R = 120 Ω <b>10</b>	-	-	<b>VW3A8306DRC</b>	0.44	0.20
	C = 1 nF <b>10</b>	-	-	<b>VW3A8306DR</b>	0.44	0.20

(1) Please refer to the "M340 Automation platform" catalog below.

(2) Cable dependent on the type of controller or PLC.

(3) Depends on the bus architecture. Please refer to the "Soft starters and variable speed drives" catalog.

(4) Sold in lots of 2.

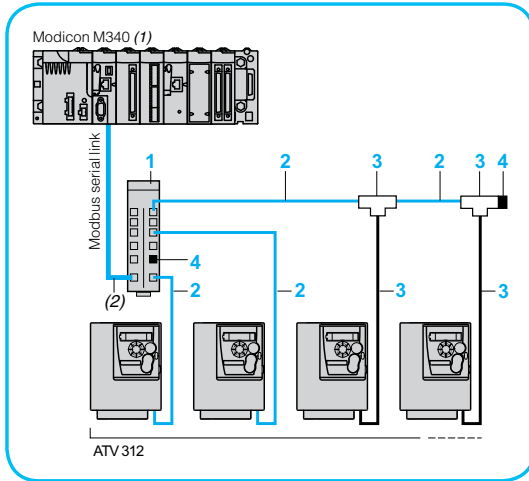

Example of Modbus serial link architecture, connections via splitter boxes and RJ45 connectors

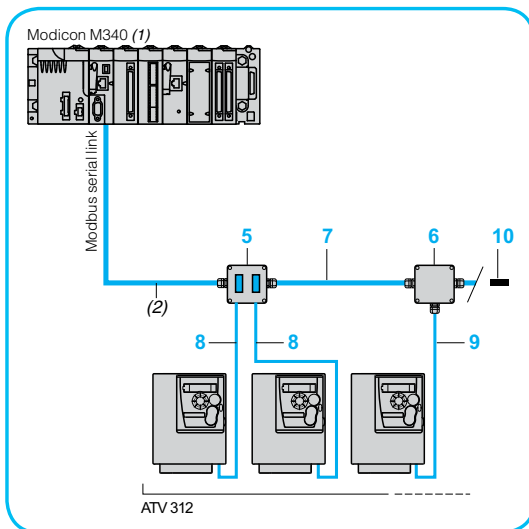

Example of Modbus serial link architecture, connections via tap junctions



TSXSACA62



TSXSACA50

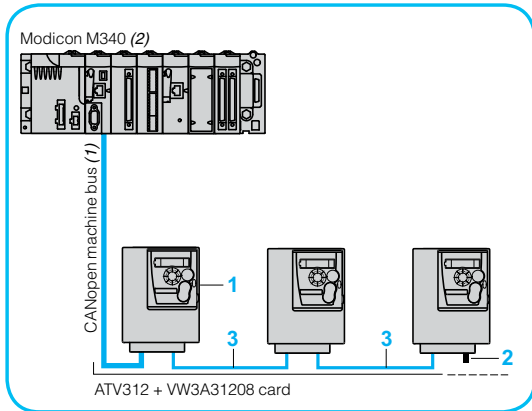

Optimized solution for daisy chain connection to the CANopen machine bus

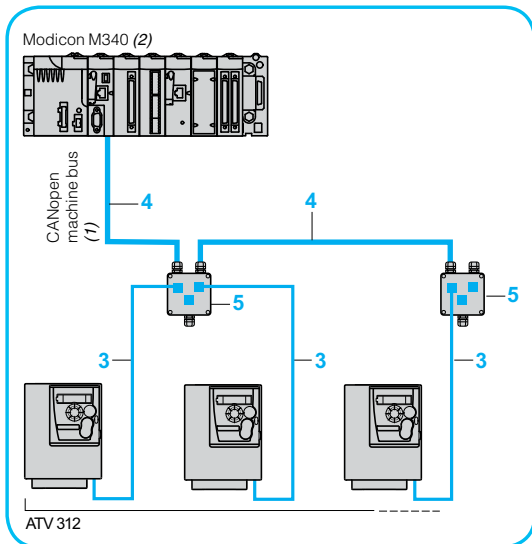

Conventional solution for connection to the CANopen machine bus



TCSCAR013M120

## Communication buses and networks

### CANopen machine bus

#### Connection with CANopen Daisy chain communication card

(optimized solution for daisy chain connection to the CANopen machine bus)

Description	Item no.	Length		Reference	Weight	
		ft	m		lbs	kg
<b>CANopen Daisy chain communication card</b>	1	-	-	<b>VW3A31208</b>	0.44	0.2
<b>CANopen line terminator</b> for RJ45 connector <sup>(4)</sup>	2	-	-	<b>TCSCAR013M120</b>	-	-
<b>CANopen cables</b> fitted with 2 RJ45 connectors	3	0.98	0.3	<b>VW3CANCARR03</b>	0.11	0.05
		3.28	1	<b>VW3CANCARR1</b>	1.10	0.5

#### Other connection accessories and cables <sup>(1)</sup>

Description	Item no.	Length		Unit reference	Weight	
		ft	m		lbs	kg
<b>CANopen cable</b> Standard cable, CE marking Low smoke emission, halogen-free Flame retardant (IEC 60332-1)	4	164.04	50	<b>TSXCANCA50</b>	10.87	4.93
		328.08	100	<b>TSXCANCA100</b>	19.40	8.8
		984.25	300	<b>TSXCANCA300</b>	54.15	24.56
<b>CANopen cable</b> Standard cable, UL certification, CE marking Flame retardant (IEC 60332-2)	4	164.04	50	<b>TSXCANCB50</b>	7.89	3.58
		328.08	100	<b>TSXCANCB100</b>	17.28	7.84
		984.25	300	<b>TSXCANCB300</b>	48.22	21.87
<b>CANopen cable</b> Cable for harsh environments <sup>(3)</sup> or mobile installations, CE marking Low smoke emission, halogen-free Flame retardant (IEC 60332-1)	4	164.04	50	<b>TSXCANCD50</b>	7.74	3.51
		328.08	100	<b>TSXCANCD100</b>	17.13	7.77
		984.25	300	<b>TSXCANCD300</b>	47.84	21.7
<b>IP20 CANopen junction boxes</b> equipped with: 2 screw terminal blocks for trunk cable tap link 2 RJ45 connectors for connecting drives 1 RJ45 connector for connecting a PC	5	-	-	<b>VW3CANTAP2</b>	0.55	0.25
<b>Daisy chain tap</b> equipped with: 2 spring terminals for daisy chain connection of the CANopen bus 1 cable equipped with an RJ45 connector for connecting a drive	-	1.97	0.6	<b>TCSCTN026M16M</b>	-	-
<b>Daisy chain tap</b> equipped with: 2 RJ45 connectors for daisy chain connection of the CANopen bus 1 cable equipped with an RJ45 connector for connecting a drive	-	0.98	0.3	<b>TCSCTN023F13M03</b>	-	-
<b>CANopen line terminator</b> for screw terminal connector <sup>(4)</sup>	-	-	-	<b>TCSCAR01NM120</b>	-	-

(1) For other connection accessories, please refer to the "Machine & installations with industrial communication" catalogue.

(2) Please refer to the "M340 Automation platform" catalogue.

(3) Standard environment:

- No particular environmental constraints
- Operating temperature between 41 °F and 140 °F (5 °C and 60 °C)
- Fixed installation

Harsh environment:

- Resistance to hydrocarbons, industrial oils, detergents, solder splashes
- Relative humidity up to 100%
- Saline atmosphere
- Operating temperature between 14 °F and 158 °F (-10 °C and +70 °C)
- Significant temperature variations

(4) Sold in lots of 2.





LUF1

## Communication buses and networks

### Other communication buses and networks

Description	Cables to be connected	Part numbers	Weight	
			lbs	kg
<b>Ethernet gateway/router (1)</b> <b>Modbus</b> Class B10 For connection to the Modbus TCP network	VW3A8306D30 (2)	<b>TSXETG100</b>	-	-
<b>Fipio/Modbus gateway (3)</b> For connection to the Fipio bus	VW3A8306R●● (2)	<b>LUF1</b>	0.53	0.24

(1) Please refer to the "Machine & installations with industrial communication" catalog.

(2) See page 39.

(3) Please refer to the "TeSys U starter-controllers" catalog.



TSXETG100



Remote display terminal with cover off



Remote display terminal with cover in place



Remote graphic display terminal

## Configuration tools

### Remote display terminal <sup>(1)</sup>

This terminal is used to locate the human-machine interface of the Altivar 312 drive remotely on the door of an enclosure with IP 54 or IP 65 protection.

It is used to:

- Control, adjust and configure the drive remotely
  - Display the drive status and detected faults remotely
- Its maximum operating temperature is 122 °F (50°C).

- 1 4-digit display
- 2 Navigation ▲, ▼ and selection ENT, ESC keys
- 3 Motor local control keys:
  - RUN: starts the motor
  - FWD/REV: reverses the direction of rotation of the motor
  - STOP/RESET: stops the motor/resets drive detected faults
- 4 Operating mode selection key MODE.
- 5 Cover for optional access to the motor local control keys.

Description	Degree of protection	Length		Part numbers	Weight	
		ft	m		lbs	kg
<b>Remote display terminals</b> A remote cable must be provided, VW3A1104R●●	IP 54	-	-	<b>VW3A1006</b>	0.55	0.25
	IP 65	-	-	<b>VW3A1007</b>	0.61	0.28
<b>Remote cables</b> equipped with 2 RJ45 connectors		3.3	1	<b>VW3A1104R10</b>	0.11	0.05
		9.8	3	<b>VW3A1104R30</b>	0.33	0.15

### Remote graphic display terminal <sup>(2)</sup>

This graphic display terminal, common to all the variable speed drive ranges, provides a user-friendly interface for configuration, debugging and maintenance.

Its main functions are as follows:

- The graphic screen displays 8 lines of 24 characters of plain text
- The navigation button provides quick and easy access to the drop-down menus
- It is supplied with six languages installed as standard (Chinese, English, French, German, Italian and Spanish). The available languages can be modified using the Multi-Loader configuration tool (VW3A8121).

Maximum operating temperature of the terminal: 140 °F (60 °C) with IP 54 protection.

- 6 Graphic display:
  - 8 lines of 24 characters, 240 x 160 pixels, large digit display
- 7 Function keys (not operational on the Altivar 312)
- 8 **Navigation button:** rotate ±: goes to the next/previous line, increases/decreases the value - press: saves the current value (**ENT**).
- ESC key:** aborts a value, a parameter or a menu to return to the previous selection.
- 9 Motor local control keys:
  - **RUN:** starts the motor
  - **STOP/RESET:** stops the motor/resets drive detected faults
  - **FWD/REV:** reverses the motor direction of rotation
- 10 Remote cable
- 11 Female/female RJ45 adaptor

Description	Item no.	Length		Part numbers	Weight	
		ft	m		lbs	kg
<b>Remote graphic display terminal</b> A remote cable, VW3A1104R●●●, and an RJ45 adaptor, VW3A1105, must be provided	5	-	-	<b>VW3A1101</b>	-	-
<b>Remote cables</b> equipped with 2 RJ45 connectors	6	3.28	1	<b>VW3A1104R10</b>	0.11	0.05
		9.84	3	<b>VW3A1104R30</b>	0.33	0.15
		16.40	5	<b>VW3A1104R50</b>	0.55	0.25
		32.81	10	<b>VW3A1104R100</b>	1.10	0.5
<b>Female/female RJ45 adaptor</b>	7	-	-	<b>VW3A1105</b>	0.02	0.01

(1) If an Altivar 31 drive is replaced by an Altivar 312 drive, the remote display terminal VW3A1101 can be used.

Please consult the Quick Start Guide for this terminal by clicking the button to the left.

(2) The software version of the graphic display terminal must be ≥ V1.1.E19. It can be updated using the Multi-Loader configuration tool (VW3A8121). See page 43.



Configuration with Simple Loader configuration tool connected to the ATV312



Configuration with Multi-Loader configuration tool connected to the ATV312

## Configuration tools (continued)

### SoMove setup software

This software enables the user to configure, set, debug and organize maintenance tasks for the Altivar 312. It can also be used to customize the integrated display terminal menus.

Description	Part number	Weight	
		lbs	kg
<b>SoMove setup software</b>	<b>Free Download</b>	-	-
<b>USB/RJ45 cordset</b> equipped with a USB connector and an RJ45 connector  For connecting a PC to the Altivar 312. Length: 8 ft (2.5 m)	<b>TCSMCNAM3M002P</b>	0.2	0.1
<b>Modbus-protocol-to-Bluetooth adaptor</b> Used to enable any non-Bluetooth device to communicate via Bluetooth wireless link <sup>(2)</sup>  Equipped with: <ul style="list-style-type: none"> <li>■ 1 Bluetooth adaptor (range 10 m, class 2) with an RJ45 connector</li> <li>■ For SoMove: 1 x 0.1 m cable with 2 x RJ45 connectors</li> <li>■ For TwidoSuite™: 1 x 0.1 m cable with 1 RJ45 connector and 1 mini DIN connector</li> </ul>	<b>VW3A8114</b>	0.3	0.2

(1) Available on our website "www.schneider-electric.us"

(2) Required for the following devices:

- Altivar 12, 212, 312, 31, 61 and 71 drives
- Altistart 22 starters
- Lexium 32 servo drives

### Simple Loader and Multi-Loader configuration tools

The Simple Loader tool enables one drive's configuration to be duplicated and transferred to another drive. It is connected through the drive's RJ45 communication port. The drive must be powered up to use the Simple Loader.

The Multi-Loader tool enables a number of configurations from a PC or drive to be copied, stored, and loaded onto other drives.

Description	Part number	Weight	
		lbs	kg
<b>Simple Loader configuration tool</b> Supplied with a cordset fitted with 2 RJ45 connectors.	<b>VW3A8120</b>	-	-
<b>Multi-Loader configuration tool</b> Supplied with: <ul style="list-style-type: none"> <li>■ 1 cordset fitted with 2 RJ45 connectors</li> <li>■ 1 cordset fitted with one type A USB connector and one mini B USB connector</li> <li>■ 1 x SD memory card</li> <li>■ 1 x female/female RJ 45 adaptor</li> <li>■ 4 AA/LR6 1.5 V batteries</li> <li>■ 1 anti-shock protection</li> <li>■ 1 carrying case</li> </ul>	<b>VW3A8121</b>	-	-
<b>Cordset for Multi-Loader tool</b> Fitted with a non-locking RJ45 connector with special mechanical catch on the drive end and an RJ45 connector on the Multi-Loader end.	<b>VW3A8126</b>	-	-

### Braking resistors

The resistor enables the Altivar 312 drive to operate while braking to a standstill or during slowdown braking, by dissipating the braking energy. Two types of resistor are available:

- Enclosed model (IP 20 casing) designed to comply with the EMC standard and protected by a temperature-controlled switch or thermal overload relay. This model enables maximum transient braking torque. The resistors are designed to be mounted on the outside of the enclosure, but should not inhibit natural cooling. Air inlets and outlets must not be obstructed in any way. The air must be free of dust, corrosive gas and condensation.
- Non-protected model (IP 00) for lower power ratings only.

For machines with high inertia, driving loads, and machines with fast cycles.

### Specifications

Type of braking resistor		VW3A7723 to VW3A7725	VW3A7701 to VW3A7705
Ambient air temperature around the device	Operation	°F 140 °F (40 °C)	32 °F to 122 °F (0 °C to 50 °C)
	Storage	°F -13 °F to 158 °F (-25 °C to +70 °C)	
Degree of protection of the casing		IP 00	IP 20
Thermal protection		None	Via temperature-controlled switch or via the drive
Temperature controlled switch <sup>(1)</sup>	Tripping temperature	°F -	120
	Max. voltage - max. current	-	250 V ~ - 1 A
	Min. voltage - min. current	-	24 V ~ - 0.1 A
	Maximum switch resistance	mΩ -	60 mΩ
Operating factor for the dynamic brake transistors		The average power that can be dissipated at 104 °F (40 °C) from the resistor into the casing is determined for a load factor during braking that corresponds to most common applications. The dynamic brake transistor is sized so that it can tolerate: <ul style="list-style-type: none"> <li>■ The nominal motor power continuously</li> <li>■ 150% of the nominal motor power for 60 s</li> </ul>	

(1) The switch must be connected in the sequence (use for signalling or in line contactor control).

### Load factor and determining the nominal power

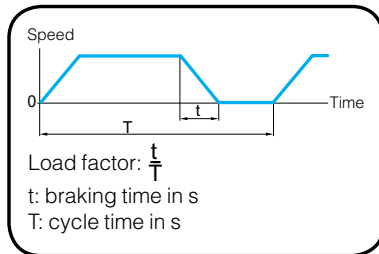

The average power that can be dissipated at 40°C from the resistor into the casing is determined for a load factor during braking that corresponds to most common applications. This load factor is defined in the table above. For a specific application (example: handling), the nominal power of the resistor must be redefined incorporating the new load factor.

Use chart 1 to determine coefficient K1 corresponding to a braking torque of **0.6 Tn** and a load factor of 20%: **K1 = 0.06**

**Chart 1**

Graph of the average power as a function of the braking torque for a load factor

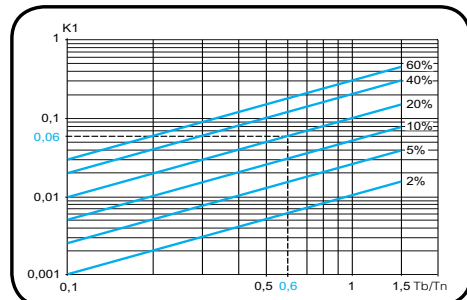

**Example:**

Motor power Pm = 4 kW  
 Motor efficiency h = 0.85  
 Braking torque Tb = 0.6 Tn  
 Braking time t = 10 s  
 Cycle time T = 50 s  
 Load factor fm =  $\frac{t}{T}$  = 20%

**Chart 2**

Permissible resistor overload as a function of time (characteristic curve)

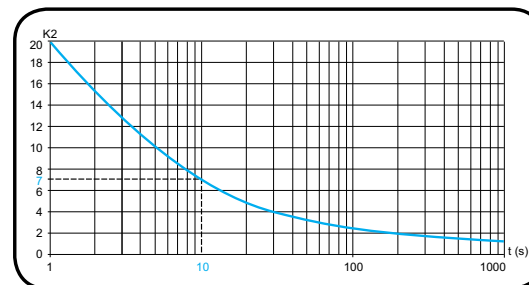

Use chart 2 to determine coefficient K2 corresponding to a braking time of **10 seconds**.

K2 = 7

**The nominal power of the resistor (Pn) must be greater than:**

$$P_n = P_m \times K_1 \times \eta \left( 1 + \frac{1}{K_2 \times f_m} \right) = 4.10^3 \times 0,06 \times 0,8 \left( 1 + \frac{1}{7 \times 0,2} \right) = 350 \text{ W}$$



VW3A7723



VW3A7701

### Braking Resistors (continued)

For drives	Minimum resistor value <sup>(1)</sup>	Ohmic value	Average power available at		Part numbers	Weight	
			104 °F (40 °C) <sup>(2)</sup>	122 °F (50 °C)		lbs	kg
			Ω	Ω			
<b>Non-protected braking resistors</b>							
ATV312H018M2...H075M2	40	100	32	28	<b>VW3A7723</b>	1.32	0.6
ATV312HU11M2, HU15M2	27						
ATV312H018M3...H075M3	40						
ATV312HU11M3, HU15M3	27						
ATV312H037N4...H075N4	80						
ATV312HU11N4...HU22N4	54						
ATV312H075S6	96						
ATV312HU15S6, HU22S6	64						
ATV312HU30N4	55	100	40	35	<b>VW3A7725</b>	1.87	0.85
ATV312HU40N4	36						
ATV312HU40S6	44						
ATV312HU22M2, ATV312HU22M3	25	68	32	28	<b>VW3A7724</b>	1.32	0.6
ATV312HU30M3	16						
<b>Protected braking resistors</b>							
ATV312H018M2...H075M2	40	100	58	50	<b>VW3A7701</b>	4.41	2.000
ATV312HU11M2, HU15M2	27						
ATV312H018M3...H075M3	40						
ATV312HU11M3, HU15M3	27						
ATV312H037N4...H075N4	80						
ATV312HU11N4...HU22N4	54						
ATV312HU22M2, ATV312HU22M3	25	60	115	100	<b>VW3A7702</b>	5.29	2.400
ATV312HU30M3	16						
ATV312HU30N4	55	100	58	50	<b>VW3A7701</b>	4.41	2.000
ATV312HU40N4	36						
ATV312HU55N4	29	60	115	100	<b>VW3A7702</b>	5.29	2.400
ATV312HU75N4	19						
ATV312HU55S6	34				<b>VW3A7703</b>	7.72	3.500
ATV312HU75S6	23						
ATV312HU40M3	16	28	231	200	<b>VW3A7703</b>	7.72	3.500
ATV312HD11N4, HD15N4	20						
ATV312HD11S6, HD15S6	24						
ATV312HU55M3, HU75M3	8	15	1154	1000	<b>VW3A7704</b>	24.25	11.000
ATV312HD11M3, HD15M3	5	10 (3)	1154	1000			

(1) Depends on the drive rating.

(2) Power that can be dissipated by the resistor at the maximum temperature of 239 °F (115 °C), corresponding to a maximum temperature rise of 167 °C (75 °C) in a 40 °C environment.

(3) Ohmic value obtained as a function of the connection described in the resistor operating instructions.



### Line chokes

Line chokes provide improved protection against overvoltages on the line supply and reduce harmonic distortion of the current produced by the drive.

The recommended chokes limit the line current. They have been developed in line with standard UL 508C.

The inductance values are defined for a voltage drop between 3% and 5% of the nominal line voltage. Values higher than this will cause loss of torque.

The use of line chokes is recommended in particular for ATV312H●●●M2, ATV312H●●●M3 and ATV312H●●●N4 drives under the following circumstances:

- Line supply with significant disturbance from other equipment (interference, overvoltages)
- Line supply with voltage imbalance between phases > 1.8% of nominal voltage  
Drive supplied by a line with very low impedance (in the vicinity of a power transformer 10 times more powerful than the drive rating)
- Installation of a large number of frequency inverters on the same line
- Reduction of overloads on the cos  $\phi$  correction capacitors, if the installation includes a power factor correction unit

The use of line chokes is mandatory for ATV312H●●●S6 drives.

The prospective short-circuit current at the drive connection point must not exceed the maximum value indicated in the reference tables. The use of chokes allows connection to the following line supplies:

- Max. Isc 22 kA for 200/240 V
- Max. Isc 65 kA for 380/500 V and 525/600V

### Specifications

Type of line choke	VZ1L004 M010	VZ1L007 UM50	VZ1L018 UM20	VW3A4 551	VW3 A4552	VW3 A4553	VW3 A4554	VW3 A4555	
Conformity to standards	IEC 61800-5-1 (VDE 0160 level 1 high-energy overvoltages on the line supply)								
Voltage drop	Between 3% and 5% of the nominal line voltage. Values higher than this will cause loss of torque.								
Degree of protection	Choke		IP 00				IP 10		
	Terminals		IP 20						
Inductance value	mH	10	5	2	10	4	2	1	0.5
Nominal current	A	4	7	18	4	10	16	30	60
Losses	W	17	20	30	45	65	75	90	80



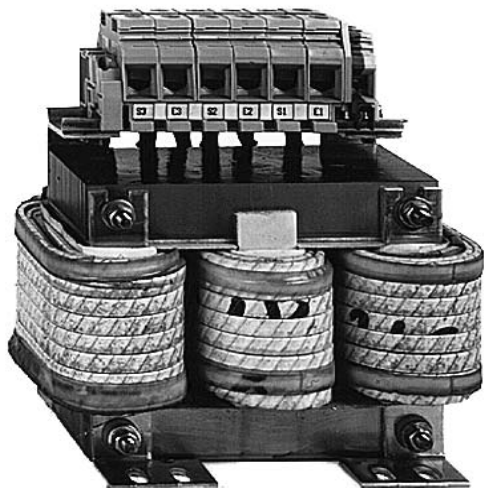

VW3A455

### Line chokes (continued)

Altivar 312	Line current				Choke		
	without choke		with choke		Part numbers	Weight	
	U min. <sup>(1)</sup>	U max. <sup>(1)</sup>	U min. <sup>(1)</sup>	U max. <sup>(1)</sup>		lbs	kg
	A	A	A	A			
<b>Single-phase supply voltage: 200...240 V 50/60 Hz</b>							
ATV312H018M2	3.0	2.5	2.1	1.8	-	-	-
ATV312H037M2	5.3	4.4	3.9	3.3	-	-	-
ATV312H055M2	6.8	5.8	5.2	4.3	-	-	-
ATV312H075M2	8.9	7.5	7.0	5.9	-	-	-
ATV312HU11M2	12.1	10.2	10.2	8.6	VZ1L018UM20	4.39	1.99
ATV312HU15M2	15.8	13.3	13.4	11.4			
ATV312HU22M2	21.9	18.4	19.2	16.1			
<b>Three-phase supply voltage: 200...240 V 50/60 Hz</b>							
ATV312H018M3	2.1	1.9	1	0.9	VW3A4551	3.31	1.5
ATV312H037M3	3.8	3.3	1.9	1.6			
ATV312H055M3	4.9	4.2	2.5	2.2			
ATV312H075M3	6.4	5.6	3.3	2.9			
ATV312HU11M3	8.5	7.4	4.8	4.2	VW3A4552	6.61	3
ATV312HU15M3	11.1	9.6	6.4	5.6			
ATV312HU22M3	14.9	13	9.2	8	VW3A4553	7.72	3.5
ATV312HU30M3	19.1	16.6	12.3	10.7			
ATV312HU40M3	24.2	21.1	16.1	14	VW3A4554	13.23	6
ATV312HU55M3	36.8	32	21.7	19			
ATV312HU75M3	46.8	40.9	29	25.2			
ATV312HD11M3	63.5	55.6	41.6	36.5	VW3A4555	24.25	11
ATV312HD15M3	82.1	71.9	55.7	48.6			
<b>Three-phase supply voltage: 380...500 V 50/60 Hz</b>							
ATV312H037N4	2.2	1.7	1.1	0.9	VW3A4551	3.31	1.500
ATV312H055N4	2.8	2.2	1.4	1.2			
ATV312H075N4	3.6	2.7	1.8	1.5			
ATV312HU11N4	4.9	3.7	2.6	2			
ATV312HU15N4	6.4	4.8	3.4	2.6			
ATV312HU22N4	8.9	6.7	5	4.1	VW3A4552	6.61	3.000
ATV312HU30N4	10.9	8.3	6.5	5.2			
ATV312HU40N4	13.9	10.6	8.5	6.6			
ATV312HU55N4	21.9	16.5	11.7	9.3	VW3A4553	7.72	3.500
ATV312HU75N4	27.7	21	15.4	12.1			
ATV312HD11N4	37.2	28.4	22.5	18.1	VW3A4554	13.23	6.000
ATV312HD15N4	48.2	36.8	29.6	23.3			
<b>Three-phase supply voltage: 525...600 V 50/60 Hz</b>							
ATV312H075S6 <sup>(2)</sup>	-	-	1.4	1.4	VW3A4551	3.31	1.500
ATV312HU15S6 <sup>(2)</sup>	-	-	2.4	2.3			
ATV312HU22S6 <sup>(2)</sup>	-	-	3.8	3.6			
ATV312HU40S6 <sup>(2)</sup>	-	-	6	5.8	VW3A4552	6.61	3.000
ATV312HU55S6 <sup>(2)</sup>	-	-	7.8	7.5			
ATV312HU75S6 <sup>(2)</sup>	-	-	11	10.7	VW3A4553	7.72	3.500
ATV312HD11S6 <sup>(2)</sup>	-	-	15	14.4			
ATV312HD15S6 <sup>(2)</sup>	-	-	21.1	20.6	VW3A4554	13.23	6.000

(1) Nominal supply voltage:

For drives	Nominal voltage	
	U min.	U max.
ATV312H●●●M2	200	240
ATV312H●●●M3		
ATV312H●●●N4	380	500
ATV312H●●●S6	525	600

(2) Line choke mandatory for ATV312H●●●S6 drives.



### EMC filters

#### Integrated filters

Altivar 312 drives, apart from ATV312H●●●M3 and ATV312H●●●S6, have integrated radio interference input filters to comply with the EMC standard for variable speed electrical power drive “products” IEC 61800-3, categories C2 or C3, and to comply with the European EMC (electromagnetic compatibility) directive.

#### Additional EMC input filters

Additional EMC input filters <sup>(1)</sup> enable drives to meet more stringent requirements: they are designed to reduce conducted emissions on the line supply below the limits of standard IEC 61800-3 category C1 or C2 (see page 49).

These additional EMC filters can be mounted beside or under the drive. They act as a support for the drives and are attached to them via tapped holes.

#### Use according to the type of line supply

Additional EMC filters can only be used on TN (neutral connection) and TT (neutral to ground) type systems.

Standard IEC 61800-3, appendix D2.1, states that on IT systems (isolated or impedance grounded neutral), filters can cause permanent insulation monitors to operate in a random manner.

The effectiveness of additional filters on this type of system depends on the type of impedance between neutral and ground, and therefore cannot be predicted. If a machine has to be installed on an IT system, one solution is to insert an isolation transformer and connect the machine locally on a TN or TT system.

### Specifications

<b>Conformity to standards</b>			EN 133200
<b>Degree of protection</b>			IP 21 and IP 41 on upper part
<b>Maximum relative humidity</b>			95% non-condensing, no dripping water conforming to IEC 60068-2-3
<b>Ambient air temperature around the device</b>	Operation	°F	14 °F to 140 °F (-10 °C to +60 °C)
	Storage	°F	13 °F to 158 °F (-25 °C to +70 °C)
<b>Maximum operating altitude</b>	Without derating	ft.	3300 ft. (1000 m)
			Above this, derate the current by 1% for every additional 330 ft. (100 m)
<b>Vibration resistance</b>	Conforming to IEC 60068-2-6		1.5 mm peak to peak from 3 to 13 Hz 1 gn peak from 13 to 150 Hz
<b>Shock resistance</b>	Conforming to IEC 60068-2-27		15 gn for 11 ms
<b>Maximum nominal voltage</b>	50/60 Hz single-phase	V	240 V + 10%
	50/60 Hz three-phase	V	240 V + 10% 500 V + 10%

(1) Not available for ATV312H●●●S6 drives





VW3A31401



VW3A31405

## EMC filters

### Additional EMC input filters

For drives	Filter									
Part number	Maximum length of shielded cable <sup>(1)</sup>		In <sup>(2)</sup>	II <sup>(3)</sup>	Losses <sup>(4)</sup>	Part number	Weight			
	IEC 61800-3 <sup>(5)</sup>						lbs	kg		
	Category C2		Category C1							
	ft	m	A	mA	W					
<b>Single-phase supply voltage: 200...240 V 50/60 Hz</b>										
ATV312H018M2	164	50	65.6	20	9	100	3.7	<b>VW3A31401</b>	1.32	0.6
ATV312H037M2										
ATV312H055M2										
ATV312H075M2										
ATV312HU11M2	164	50	65.6	20	16	150	6.9	<b>VW3A31403</b>	1.71	0.78
ATV312HU15M2										
ATV312HU22M2	164	50	65.6	20	22	80	7.5	<b>VW3A31405</b>	1.13	1.13
<b>Three-phase supply voltage: 200...240 V 50/60 Hz</b>										
ATV312H018M3	16.4	5	-	-	7	7	2.6	<b>VW3A31402</b>	1.43	0.65
ATV312H037M3										
ATV312H055M3										
ATV312H075M3										
ATV312HU11M3	16.4	5	-	-	15	15	9.9	<b>VW3A31404</b>	2.2	1.00
ATV312HU15M3										
ATV312HU22M3										
ATV312HU30M3	16.4	5	-	-	25	35	15.8	<b>VW3A31406</b>	3.64	1.65
ATV312HU40M3										
ATV312HU55M3	16.4	5	-	-	47	45	19.3	<b>VW3A31407</b>	6.94	3.15
ATV312HU75M3										
ATV312HD11M3	16.4	5	-	-	83	15	35.2	<b>VW3A31408</b>	11.68	5.30
ATV312HD15M3										
<b>Three-phase supply voltage: 380...500 V 50/60 Hz</b>										
ATV312H037N4	164	50	65.6	20	15	15	9.9	<b>VW3A31404</b>	2.2	1.00
ATV312H055N4										
ATV312H075N4										
ATV312HU11N4										
ATV312HU15N4										
ATV312HU22N4	164	50	65.6	20	25	35	15.8	<b>VW3A31406</b>	3.64	1.65
ATV312HU30N4										
ATV312HU40N4										
ATV312HU55N4	164	50	65.6	20	47	45	19.3	<b>VW3A31407</b>	6.94	3.15
ATV312HU75N4										
ATV312HD11N4	164	50	65.6	20	49	45	27.4	<b>VW3A31409</b>	10.47	4.75
ATV312HD15N4										

(1) The filter selection tables give the maximum lengths for shielded cables connecting motors to drives for a switching frequency of 2 to 16 kHz. These maximum lengths are given as examples only, as they vary depending on the stray capacitance of the motors and the cables used.

If motors are connected in parallel, the sum of the cable lengths must be taken into account.

(2) In: nominal filter current.

(3) II: maximum ground leakage current at 50 Hz.

(4) Via heat dissipation, at the nominal filter current (In).

(5) Standard IEC 61800-3: EMC immunity and conducted and radiated EMC emissions:

- Category C1: public power supply (residential)

- Category C2: industrial power supply

### Output filters, motor chokes, and ferrite suppressors

Output filters and motor chokes can be inserted between the Altivar 312 drive and the motor to:

- Limit the dv/dt at the motor bb terminals (500 to 1500 V/μs), for cables longer than 164 ft. (50 m)
- Filter interference caused by opening a contactor placed between the filter and the motor
- Reduce the motor ground leakage current

The output filter range features LR filter cells.

Ferrite suppressors are necessary on ATV312H●●●M2 and ATV312H018M3 to ATV312HU22M3 drives when an output contactor is used.

#### *LR filter cell*

This cell features 3 high-frequency chokes and 3 resistors.

The LR filter cell is particularly suitable for:

- Reducing the dv/dt at the motor terminals
- Using long motor cables (see specifications table page 51)

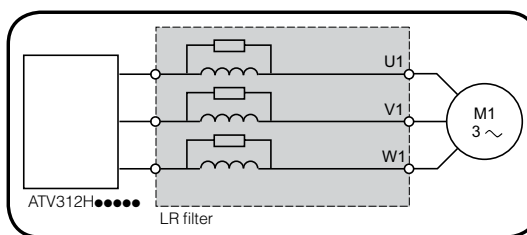

#### *Motor choke*

The motor choke is particularly suitable for:

- Reducing overvoltages at the motor terminals (see length of motor cable in specifications table page 51)
- Minimizing the current wave, thus reducing motor noise

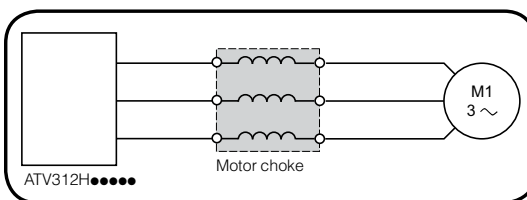

#### *Ferrite suppressors for downstream contactor opening*

Ferrite suppressors for downstream contactor opening are inserted on the motor

cable between ATV312H●●●M2 or ATV312H018M3 to ATV312HU22M3 drives and the output contactor.

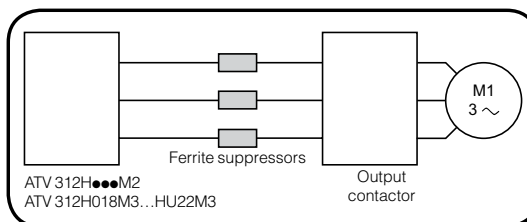

### Output filters, motor chokes, and ferrite suppressors

#### Specifications <sup>(1)</sup>

			LR filter cells <sup>(2)</sup>	Motor chokes	
			VW3A5845●	VW3A4552...A4555	VW3A4556
Drive switching frequency		kHz	0.5...4	4	
Length of motor cable	Shielded cables	ft	≤ 330 ft. (≤ 100 m)	≤ 330 ft. (≤ 100 m)	
	Unshielded cables	ft	≤ 660 ft. (≤ 200 m)	≤ 660 ft. (≤ 200 m)	
Degree of protection			IP 20	IP 20	IP 00

#### Part Numbers

Motor chokes						
Designation	For drives	Losses	Nominal current	Reference	Weight	
		W	A		lbs	kg
Motor chokes	ATV312HU22N4...HU40N4 ATV312HU40S6, HU55S6	65	10	VW3A4552	6.6	3
	ATV312HU22M2 ATV312HU22M3, HU30M3 ATV312HU55N4 ATV312HU75S6	75	16	VW3A4553	7.7	3.5
	ATV312HU40M3...HU75M3 ATV312HU75N4, HD11N4 ATV312HD11S6, HD15S6	90	30	VW3A4554	13.2	6
	ATV312HD15N4	80	60	VW3A4555	24.3	11
	ATV312HD11M3, HD15M3	–	100	VW3A4556	35.3	16

Ferrite suppressors for downstream contactor opening						
Designation	For drives	Sold in lots of	Unit reference	Weight		
				lbs	kg	
Ferrite suppressors for downstream contactor opening	ATV312H018M2	3	VW3A31451	0.7	0.3	
	ATV312H037M2 ATV312H018M3, H037M3	3	VW3A31452	0.4	0.2	
	ATV312H055M2...HU22M2 ATV312H055M3...HU22M3	3	VW3A31453	0.2	0.1	

(1) Filter performance is ensured if the cable lengths between the motor and the drive, given in the above table, are not exceeded. For an application with several motors connected in parallel, the cable length must include all cabling. If a cable longer than that recommended is used, the filters may overheat.

(2) For other LR filter configurations, please consult your Customer Care Center.

## Wiring Diagrams

ATV312H●●●M2

Single-phase power supply

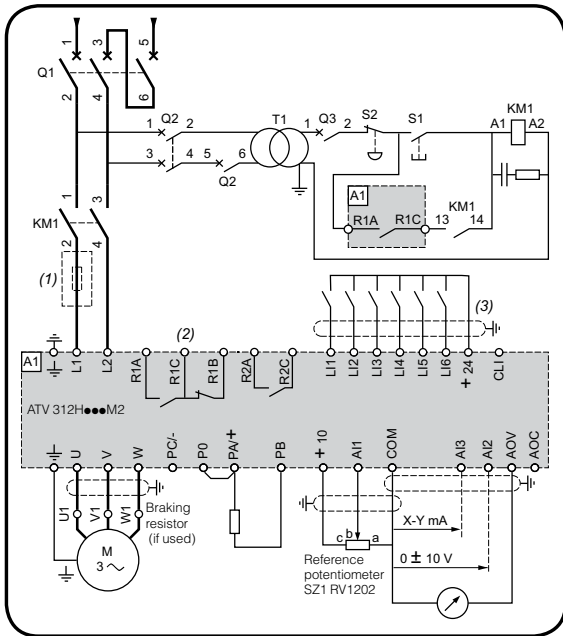

ATV312H●●●M3, ATV312H●●●N4, ATV312H●●●S6

Three-phase power supply

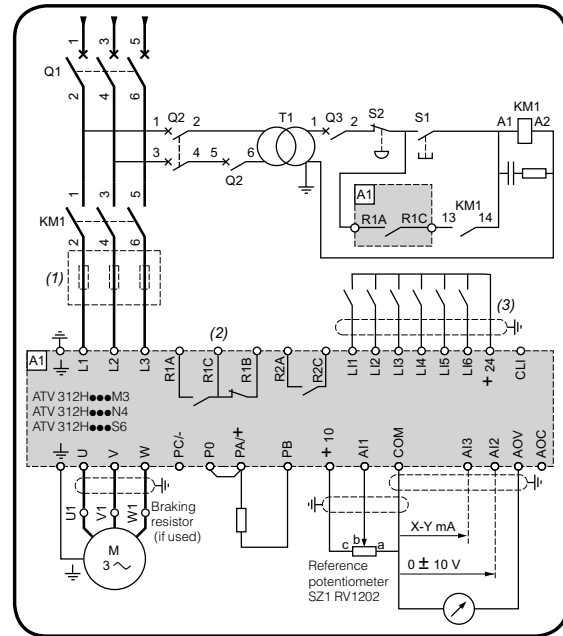

- (1) Line choke (single-phase or three-phase).  
 (2) Detected fault relay contacts. Used for remote signalling of the drive status.  
 (3) Connection of the common for the logic inputs depends on the position of the switch (see schemes below).

**Note:** All terminals are located at the bottom of the drive. Install interference suppressors on all inductive circuits near the drive or connected on the same circuit, such as relays, contactors, solenoid valves, fluorescent lighting, etc.

Compatible components (for a complete part number list, please refer to "Motor starter solutions - Control and protection components" catalog)

Item no.	Designation
KM1	Line contactor LC1●●● + suppressor module LA4DA2U
Q1	GV2 L magnetic circuit-breaker or Compact NS circuit-breaker
Q2	GV2 L magnetic circuit-breaker rated at twice the nominal primary current of T1
Q3	GB2 CB05 thermal magnetic circuit breaker
S1, S2	XB4 B or XB5 A pushbuttons
T1	100 VA transformer 220 V secondary

### Examples of recommended schemes

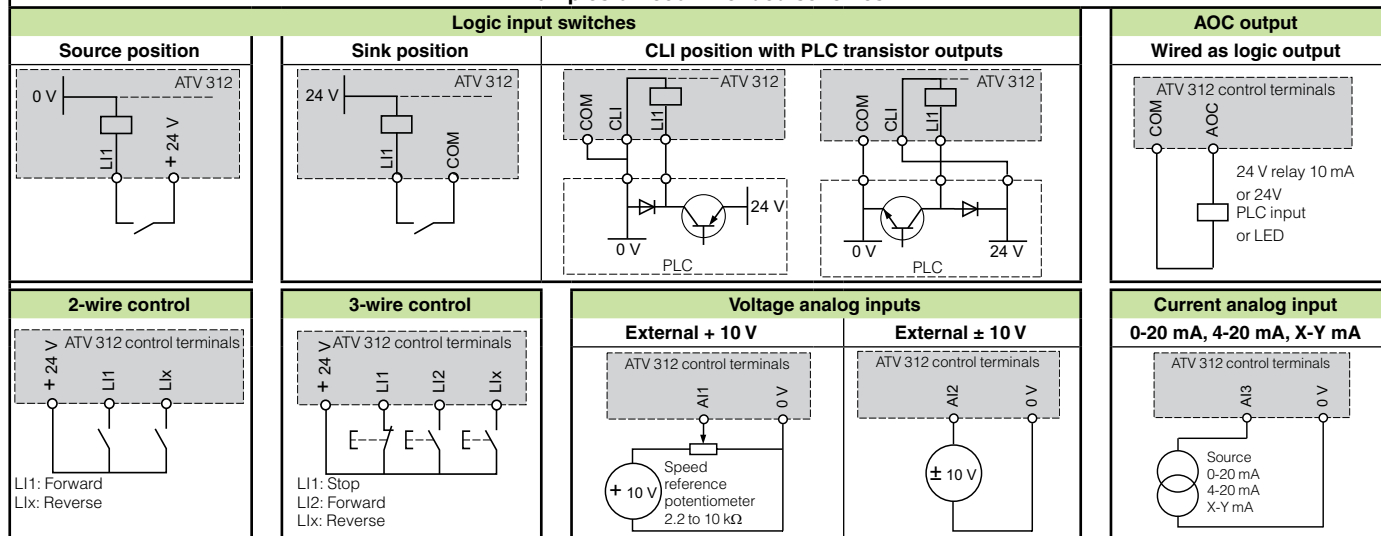

## Wiring Diagrams (continued)

### Additional EMC input filters VW3A3140●

#### Single-phase power supply

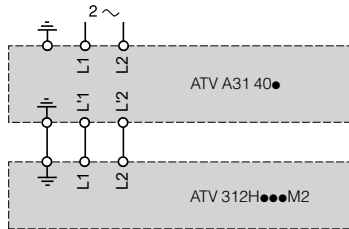

#### Three-phase power supply

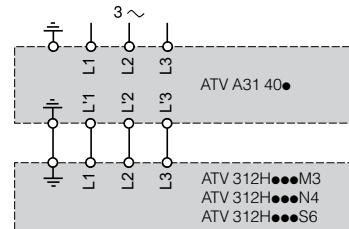

### Connections ensuring conformity to EMC standards

#### Principle

- Grounds between the drive, motor and cable shielding must have “high-frequency” equipotentiality.
- Use shielded cables with the shielding connected to ground throughout 360° at both ends for the motor cable, the braking resistor cable and the control-signal cables. Metal conduit or ducting can be used for part of the shielding length provided that there is no break in the continuity of the ground connection.
- Ensure maximum separation between the power supply cable and the motor cable.

#### Installation diagram

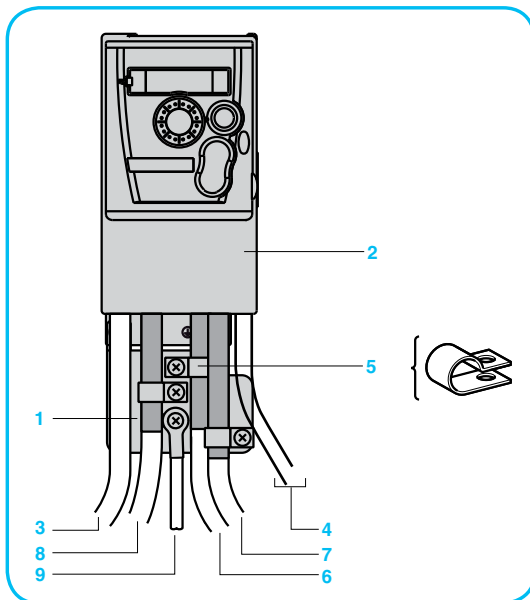

- 1 Steel plate to be mounted on the drive (earthed casing)
- 2 Altivar 312 drive
- 3 Unshielded power supply wires or cable
- 4 Unshielded wires or cable for the output of the detected fault relay contacts
- 5 Attach and ground the shielding of cables 6, 7 and 8 as close as possible to the drive:
  - Strip the cable to expose the shielding
  - Attach the cable to the plate 1, attaching the clamp on the stripped part of the shielding.
 The shielding must be clamped tightly enough to the metal sheet to ensure good contact.
- For cables 6, 7 and 8, the shielding must be connected to ground at both ends. The shielding must be continuous, and if intermediate terminals are used, they must be placed in EMC shielded metal boxes.
- 6 Shielded cable for connecting the motor
- 7 Shielded cable for connecting the control-signal wiring. For applications requiring several conductors, use cables with a small cross-section (0.5 mm<sup>2</sup>).
- 8 Shielded cable for connecting the braking resistor
- 9 PE cable (green-yellow)

**Note:** The HF equipotential ground connection between the drive, motor and cable shielding does not remove the need to connect the PE conductors (green-yellow) to the appropriate terminals on each device. If using an additional EMC input filter, it must be mounted under the drive and connected directly to the line supply via an unshielded cable. Link 3 on the drive is then via the filter output cable.

#### Operation on an IT system (isolated or impedance grounded neutral)

Use a permanent insulation monitor compatible with non-linear loads, such as the Schneider Electric XM200 (please consult our website [www.schneider-electric.com](http://www.schneider-electric.com) or contact your Customer Care Center).

ATV312H●●●M2 and ATV312H●●●N4 drives have integrated EMC filters. For use on an IT system, these filters can be disconnected by removing their ground connection:

- For ATV312H018M2...HU22M2 and H037N4...HU40N4 drives, remove a jumper to disconnect the filter.
- For ATV312HU55N4...HD15N4 drives, move the wire with the cable tag to disconnect the filter.

### Installation recommendations

Depending on the conditions in which the drive is to be used, its installation will require certain precautions and the use of appropriate accessories.

Install the unit vertically, at  $\pm 10^\circ$ :

- Do not place it close to heating elements
- Leave sufficient free space to ensure that the air required for cooling purposes can circulate from the bottom to the top of the unit

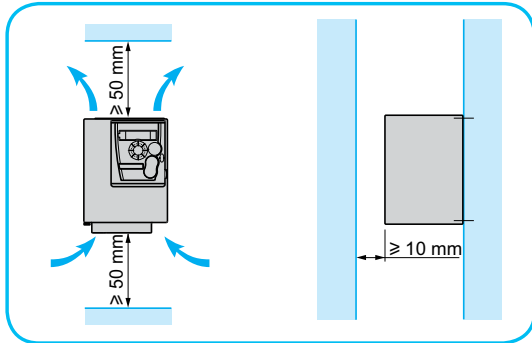

Description of installation recommendations

### Mounting types

#### Type A mounting

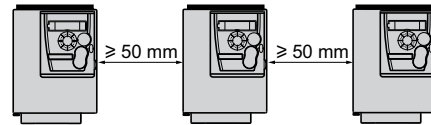

#### Type B mounting

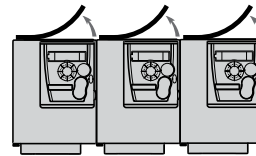

#### Type C mounting

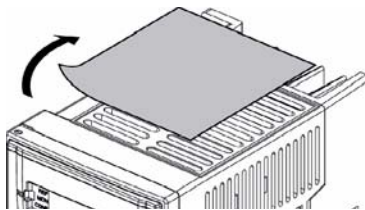
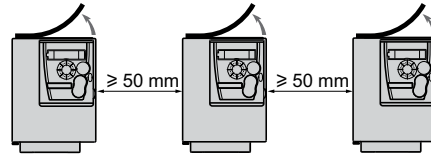

Removing the protective cover

Removing the protective cover from the top of the drive (as shown opposite) changes the degree of protection to IP 20.

**Derating curves** for the nominal drive current ( $I_n$ ) as a function of temperature, switching frequency and mounting type.

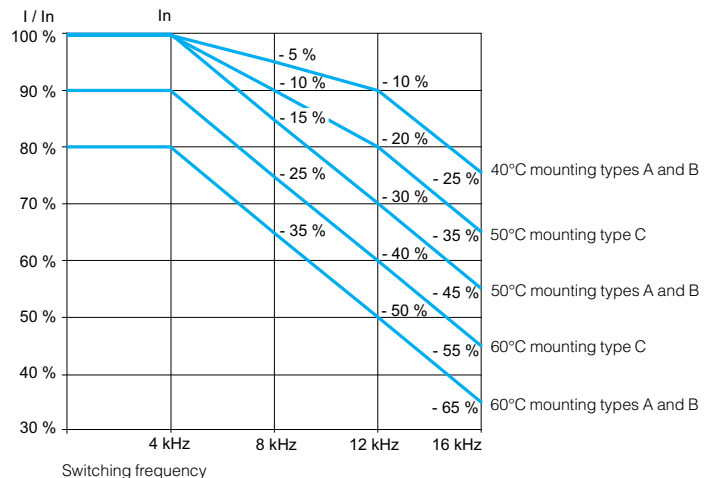

For intermediate temperatures (for example, 131 °F (55°C)), interpolate between 2 curves.

## Installation recommendations

### Mounting in an enclosure

Follow the mounting recommendations on the opposite page.

To ensure proper air circulation in the drive:

- Install ventilation grilles
- Ensure that there is sufficient ventilation. If there is not, install a forced ventilation unit with a filter. The openings and/or fans must provide a flow rate at least equal to that of the drive fans (see below).
- Use special filters with IP 54 protection
- Remove the protective cover from the top of the drive

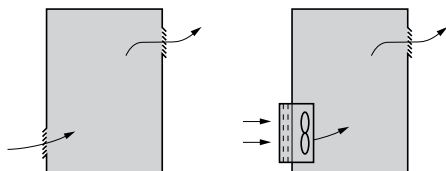

Example of airflow for the ATV312

### Fan flow rate depending on the drive rating

ATV312	Flow rate m <sup>3</sup> /min
H018M2...H055M2 H018M3...H055M3 H037N4...HU11N4 H075S6, HU15S6	0.3
H075M2...HU15M2 H075M3...HU15M3 HU15N4, HU22N4 HU22S6, HU40S6	0.55
HU22M2 HU22M3...HU40M3 HU30N4, HU40N4 HU55S6, HU75S6	1.55
HU55M3 HU55N4, HU75N4 HD11S6	1.7
HU75M3, HD11M3 HD11N4, HD15N4 HD15S6	2.8
HD15M3	3.6

### Metal dust/damp proof wall-mounted or floor-standing enclosure (IP 54 protection)

The drive must be mounted in a dust and damp proof enclosure in certain environmental conditions: dust, corrosive gases, high humidity with risk of condensation and dripping water, splashing liquid, etc.

This enables the drive to be used in an enclosure where the maximum internal temperature can reach 122 °F (50°C).

### Calculating the dimensions of the enclosure

Maximum thermal resistance  $R_{th}$  (°C/W)

$$R_{th} = \frac{\theta^{\circ} - \theta_e}{P}$$

$\theta^{\circ}$  = maximum temperature inside the enclosure in °C  
 $\theta_e$  = maximum external temperature in °C  
 $P$  = total power dissipated in the enclosure in W

Power dissipated by drive: see page 32.

Add the power dissipated by the other components of the device.

Useful heat exchange area of enclosure  $S$  (m<sup>2</sup>)

(sides + top + front panel if wall-mounted)

$$S = \frac{K}{R_{th}} \quad K = \text{thermal resistance per m}^2 \text{ of the enclosure}$$

For metal enclosures:

- $K = 0.12$  with internal fan
- $K = 0.15$  without fan

**Note:** Do not use insulated enclosures, as they have a poor level of conductivity.

# Altivar 312 variable speed drives

## Combinations



GV2P14  
+  
LC1D09  
+  
ATV312HU30N4

### Combinations

The combinations listed below can be used to assemble a complete motor starter comprising a circuit-breaker, a contactor and an Altivar 312 variable speed drive. The circuit-breaker provides protection against accidental short-circuits, disconnection and, if necessary, isolation.

The contactor controls and manages any safety features and isolates the motor on stopping.

The Altivar 312 drive is protected electronically against short-circuits between phases and between phase and ground. It therefore ensures continuity of service and thermal protection of the motor.

### Motor starters

Standard power rating of 50/60 Hz 4-pole motors <sup>(1)</sup>		Drive Part number	Circuit-breaker Part number		Contactor <sup>(2)</sup> Add voltage reference to basic reference to obtain full reference <sup>(3)</sup>
HP	kW		Rating A	Rating A	
<b>Single-phase supply voltage: 200...240 V</b>					
0.25	0.18	ATV312H018M2	-	4	LC1D09●●
0.5	0.37	ATV312H037M2	-	6.3	LC1D09●●
0.75	0.55	ATV312H055M2	-	10	LC1D09●●
1	0.75	ATV312H075M2	-	10	LC1D09●●
1.5	1.1	ATV312HU11M2	-	14	LC1D09●●
2	1.5	ATV312HU15M2	-	18	LC1D09●●
3	2.2	ATV312HU22M2	-	25	LC1D09●●
<b>Three-phase supply voltage: 200...240 V</b>					
0.25	0.18	ATV312H018M3	-	2.5	LC1D09●●
0.5	0.37	ATV312H037M3	-	4	LC1D09●●
0.75	0.55	ATV312H055M3	-	6.3	LC1D09●●
1	0.75	ATV312H075M3	-	10	LC1D09●●
1.5	1.1	ATV312HU11M3	GV2P14	10	LC1D09●●
2	1.5	ATV312HU15M3	GV2P16	14	LC1D09●●
3	2.2	ATV312HU22M3	GV3P18/13	18	LC1D09●●
-	3	ATV312HU30M3	GV3P18	25	LC1D09●●
5	4	ATV312HU40M3	GV3P25	25	LC1D09●●
7.5	5.5	ATV312HU55M3	GV3P40/32	40	LC1D32●●
10	7.5	ATV312HU75M3	GV3P50	50	LC1D32●●
15	11	ATV312HD11M3	GV3P65	65	LC1D50●●
20	15	ATV312HD15M3	-	100	LC1D80●●
<b>Three-phase supply voltage: 380...500 V</b>					
0.5	0.37	ATV312H037N4	GV2P07	2.5	LC1D09●●
0.75	0.55	ATV312H055N4	GV2P07	4	LC1D09●●
1	0.75	ATV312H075N4	GV2P08	4	LC1D09●●
1.5	1.1	ATV312HU11N4	GV2P08	6.3	LC1D09●●
2	1.5	ATV312HU15N4	GV2P10	10	LC1D09●●
3	2.2	ATV312HU22N4	GV2P14	10	LC1D09●●
-	3	ATV312HU30N4	GV2P14	14	LC1D09●●
5	4	ATV312HU40N4	GV3P13	14	LC1D09●●
7.5	5.5	ATV312HU55N4	GV3P18	25	LC1D09●●
10	7.5	ATV312HU75N4	GV3P25	32	LC1D18●●
15	11	ATV312HD11N4	GV3P32	40	LC1D25●●
20	15	ATV312HD15N4	GV3P40	50	LC1D32●●

(1) The values expressed in HP conform to the NEC (National Electrical Code).

(2) Composition of contactors LC1-D09/D18/D25/D32/D50/D80:

3 poles + 1 N/O auxiliary contact + 1 N/C auxiliary contact.

(3) Replace pp with the control circuit voltage reference indicated in the table below:

### AC control circuit

	Volts ~	24	48	110	220	230	230/240
LC1-D	50/60 Hz	B7	E7	F7	M7	P7	U7

For other voltages between 24 V and 660 V, or a DC control circuit, please refer to the "Motor starter solutions - Control and protection components" catalog.





GV3P40  
+  
LC1D32●●  
+  
ATV312HD15N4

## Combinations

### Motor starters

Standard power rating of 50/60 Hz 4-pole motors <sup>(1)</sup>		Drive	Circuit-breaker		Contactor <sup>(2)</sup>
HP	kW	Part number	Part number	Rating A	Add voltage reference to basic reference to obtain full reference <sup>(3)</sup>
<b>Three-phase supply voltage: 525...600 V</b>					
1	0.75	ATV312HU075S6	-	4	LC1D09●●
2	1.5	ATV312HU15S6	-	6.3	LC1D09●●
3	2.2	ATV312HU22S6	-	10	LC1D09●●
5	4	ATV312HU40S6	-	14	LC1D09●●
7.5	5.5	ATV312HU55S6	-	18	LC1D09●●
10	7.5	ATV312HU75S6	-	25	LC1D09●●
15	11	ATV312HD11S6	-	32	LC1D18●●
20	15	ATV312HD15S6	-	40	LC1D25●●

(1) The values expressed in HP conform to the NEC (National Electrical Code).

(2) Composition of contactors LC1-D09/D18/D25/D32/D50/D80:

3 poles + 1 N/O auxiliary contact + 1 N/C auxiliary contact.

(3) Replace pp with the control circuit voltage reference indicated in the table below:

### AC control circuit

	Volts ~	24	48	110	220	230	230/240
<b>LC1-D</b>	50/60 Hz	B7	E7	F7	M7	P7	U7

For other voltages between 24 V and 660 V, or a DC control circuit, please refer to the "Motor starter solutions - Control and protection components" catalog.



### Quality Assurance

This document communicates a summary of the processes, procedures & quality assurance that are in place for the manufacturing of the Altivar 312. Altivar 312 drives are produced in ISO certified facilities. Customers can be assured that these processes and procedures are followed. Audits conducted by third party representatives verify documented processes and procedures are followed and provide certification to ISO 14001. Schneider Electric utilizes quality assurance processes and procedures to verify the integrity of components and the assembly process. Data is gathered on each unit and tracked via the unique serial number of each unit during the manufacturing process. The document was not intended to imply this data is available in a format that could be easily communicated externally nor that a written report is generated for each product.

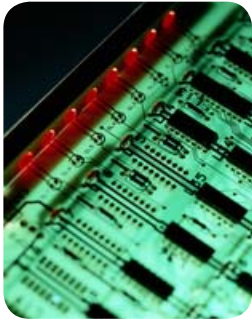

#### *Outline of Test Process and Procedures*

Printed circuit board testing, dielectric testing, preliminary memory and functional test, unit operation with burn-in testing, and final verification testing are conducted at various points in the manufacturing process for each drive. All aspects of these tests during the assembly are logged electronically for internal tracking purposes. Each unit is checked and product conformance status is recorded at each test station. Appropriate conformance information is carried in nonvolatile memory within the unit. The sequence of testing is monitored. Each test station requires a successful bar code scan on entry to ensure each drive has successfully completed any prerequisite test stations.

In addition to the processes and procedures detailed below, each test station has a visual quality inspection check list. This check list includes a physical inspection for proper connections, power component polarities, proper assembly torques, mechanical integrity and proper documentation.

#### *Printed Circuit Board Testing*

Printed circuit boards used in the assembly of the ATV312 undergo testing as a part of the board assembly. These tests include:

- In-circuit, component level testing
- Functional power-on testing
- Thermal-cycle stress testing
- High-potential test applied to high voltage boards

#### *Dielectric Testing (Hi Pot Test)*

This test verifies the dielectric withstand between customer connection points and ground to validate that the required isolation barriers are intact. Isolation barriers are typically tested for a duration of one (1) second during which a high voltage is applied according to IEC 61800-5-1 standard. This station is also used to verify placement of the power circuit connections.

#### *Preliminary memory and functional testing*

During this test, the unit's on-board communication port is utilized to read internal memory and set aside a portion of memory to track the processes performed on the drive and its main components. Each tracked process must have been completed successfully to proceed. These include:

- Supplier preformed tests of printed circuit boards with on-board memory.
- Successful drive hi-pot test.

#### **A preliminary test is run to verify:**

- Heatsink ground screw presence
- RFI filter jumper setting
- DC bus Jumper presence
- EEPROM test
- Product rating verification
- Initial rating verification
- Analog input calibration
- Analog output calibration
- Self test (verification of the display board and control terminal board)
- Pre-motor test

---

### *Unit operation and burn-in testing*

Burn-in testing involves four aspects - (I) sample plan, (II) thermal profile, (III) electrical cycling, and (IV) load cycling. Each will vary slightly by the equipment available at each production facility and by the current quality results experienced by each production facility.

---

#### *(I) Sample Plan*

Burn-in is sampled at a rate that varies from 5% to 100%. The rate is based on current quality results for each production facility. Each production facility is required to burn-in at sample rates determined by the following model.

---

#### *(II) Thermal Profile*

Constant elevated temperature of 60°C for two hours during which the drive is subjected to electrical cycling for the entire duration of the thermal profile.

---

#### *(III) Electrical Cycles*

The electrical cycle runs concurrently with the thermal profile. An electrical cycle energizes and de-energizes the drive by connecting and removing AC input power. The drive is energized for the duration of a load cycle (typically 4 minutes) and de-energized to allow the drive power supply to shut down (typically 40 seconds). This cycle repeats continuously during the portions of the thermal profile indicated above. This cycle is repeated continuously during the thermal profile.

---

#### *(IV) Load Cycles*

Drives are connected to an inertial motor load during burn-in. When the drive is energized, the drive is cycled between high speed forward and reverse operations. Load cycles are made at a minimum interval of 10 seconds. Acceleration and deceleration rates are 0.1s (minimum). The rates are selected to maximize transition stress.

---

### *Monitoring during burn-in cycle*

The drive detected fault register and drive speed are monitored during the load cycle. If the drive does not reach the commanded speed then it stops and then indicates that it did not pass the test.

---

### *Final verification testing*

This test validates proper operation after burn-in and prepares the drive settings for customer shipment. The following checks are made:

- DC bus pre-charge check
- Communication port test
- Product model verification
- 7 segment LED display check
- DC charge LED check
- CPU version check
- DC bus level check
- Fan operation test
- Nominal load characteristic check
- Overcurrent test
- Ground detected fault trip test
- Brake transistor off check
- Brake transistor on check
- Set factory default configuration

This document provides information regarding the quality assurance processes and procedures that are in place for the manufacturing of Altivar 312. These are in place to monitor and confirm the quality of the product line that has been designed in from the outset.



## Solutions for every stage of your equipment's life cycle

Schneider Electric™ provides services far beyond meeting your immediate needs for application or equipment repair. We take a long-term, holistic approach to determine your facility and operational needs and develop a strategy for improving the performance of your people, systems, and processes.

Schneider Electric provides services from system design and consulting, to maintenance support, modernization of your installation, and project delivery. Schneider Electric provides the people, tools, and processes to help maximize your business's infrastructure.

Our expertise enables you to cut costs, reduce energy consumption, and keep your systems up and running through routine maintenance, added enhancements, and migrations to new state-of-the-art functionality.

### > Start-up and commissioning

Expert installation support to provide assistance in the start-up of your new system. Service includes a comprehensive power-up and diagnostic check on system components to minimize risk and optimize operation.

### > Technical training

Training offered on-site, off-site, or online for Schneider Electric automation products taught by professional instructors with up-to-date knowledge of our latest hardware and software.

### > Remote technical support

Comprehensive online and phone support from experts specially trained on Schneider Electric drive products, helping to reduce downtime and costs and optimize your system's life cycle.

### > On-site technical support

Support service to perform regular maintenance, upgrades, and conversion assistance, small application and programming assistance, on-the-job training, equipment repair, support and troubleshooting, even in emergency situations.

### > Preventative maintenance

Maintenance programs to scan for, and proactively detect, potential issues or problems with your automation system to help you avoid the costs of unscheduled downtime and short equipment service life. Also serves to extend the life of your installed base by using our services to properly maintain your equipment.

### > Industrial repair services

Repair capabilities for over 400,000 part numbers from more than 2,500 manufacturers at our Greensboro, NC repair facility. Repair is available for both Schneider Electric and non-Schneider Electric equipment.

### > Spare parts management

Save money and reduce downtime through our parts management program. An on-site assessment is performed to determine parts and inventory levels needed to ensure proper system operation and reduce downtime and inventory costs.

### > Migration and modernization

Realize the productivity benefits of the latest Schneider Electric automation technology by using our assessment tools to identify and implement replacement of your legacy automation products, regardless of brand. We make extensive use of existing hardware and wiring for a cost-effective solution with minimal downtime.

### > Software renewals

Access the latest software, firmware, and custom options to ensure you always have the latest functionality available to optimize your system's life cycle.

### > Extended warranty

Extend your Schneider Electric standard manufacturer warranty from one year to five years. Protection plans are tailored to your needs reducing costs and out-of-service time.

### > When it comes to your automation equipment, we can help you

- Increase productivity
- Improve reliability and safety
- Mitigate risk and limit downtime
- Keep equipment up to date
- Extend the life of your installed base
- Cut costs and increase savings
- Improve your return on investment

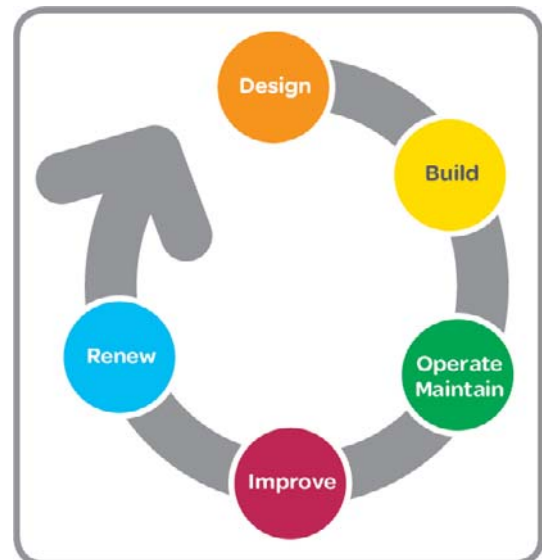

## Talk to someone you can trust

The Altivar family of variable speed AC drives and the Altistart™ family of soft starts presents the most advanced and user-friendly solutions in the marketplace. Featuring proprietary motor control algorithms to achieve optimal reaction times and complete scalability to match your application requirements for speed, size, and protection, the complete line of Altivar and Altistart products provides the flexibility and performance to:

- Meet the needs of a broad range of industries, including HVAC, pump, material handling, hoisting, packaging and many more.
- Reduce your energy costs using proprietary energy-saving technologies available only from Schneider Electric.
- Improve your up-time by simplifying installation, commissioning and maintenance by providing advanced diagnostics, industry-leading voltage ride thru capability and seismic qualified products.

We also work with you to deliver the benefits of a global service and support of a global service and support organization to further increase the value of working with Schneider Electric. Our product specialists, industry experts, distributors, partners, and the countless other members of the Schneider Electric family are dedicated to helping you make the most of your energy everyday. Contact your local sales representative today to learn how Schneider Electric can improve operational performance and help your business to achieve a competitive advantage. Or visit [www.schneider-electric.com](http://www.schneider-electric.com)

### >Drive Product Support Group

For support and assistance, contact the Drive Product Support Group. The Drive Product Support Group is staffed from 8:00 am until 6:00 pm Eastern time to assist with product selection, start-up, and diagnosis of product or application problems.

EMERGENCY Technical phone support is available 24 hours a day, 365 days a year.

Toll Free **1-888-778-2733**

E-mail **[drive.products.support@us.schneider-electric.com](mailto:drive.products.support@us.schneider-electric.com)**

Fax **919-217-6508**

### >Schneider Electric Service (On-Site)

The Schneider Electric Services division is committed to providing quality on-site service that consistently meets customer expectations. Services responds to your requests, seven days a week, 24 hours a day.

Phone **1-888-778-2733**

### >Schneider Electric Customer Training

Schneider Electric offers a variety of instructor-led skill enhancing and technical product training programs for customers. For a complete list of drives/soft start training with dates, locations, and pricing please call:

Phone **978-975-9306**

Fax **978-975-2821**

### >Customer Care Center

(Assist with stock checks, assist with claims, and assist with order management issues)

To provide additional support, Schneider Electric has rolled out new Technical Service Representatives in local offices which have the strongest needs.

Due to time zone changes and different time operation requirements business operation times vary.

Phone **888-778-2733**

Fax **888-329-9773**



**Schneider Electric USA, Inc.**

Schneider Electric USA, Inc.  
8001 Knightdale Blvd.  
Knightdale, NC 27545

USA Customer Care Center  
Tel: 888-778-2733

© 2014 Schneider Electric. All Rights Reserved. Schneider Electric, Altivar, Altistart, Powerpace, SoMove, Fipio, Modbus, and TeSys are the property of Schneider Electric SE, its subsidiaries and affiliated companies. All other trademarks are the property of their respective owners.

The information provided in this documentation contains general descriptions and/or technical characteristics of the performance of the products contained herein. This documentation is not intended as a substitute for and is not to be used for determining suitability or reliability of these products for specific user applications. It is the duty of any such user or integrator to perform the appropriate and complete risk analysis, evaluation and testing of the products with respect to the relevant specific application or use thereof. Neither Schneider Electric nor any of its affiliates or subsidiaries shall be responsible or liable for misuse of the information contained herein.

Design: Schneider Electric  
Photos: Schneider Electric

8800CT1405  
September 2014 - V1.0