

Slide Unit

CX2/CXWM/CXWL Series

Slide Bearing/CX2: $\phi 10$, $\phi 15$, $\phi 25$ CXWM: $\phi 10$, $\phi 16$, $\phi 20$, $\phi 25$, $\phi 32$
 Ball Bushing Bearing/CXWL: $\phi 10$, $\phi 16$, $\phi 20$, $\phi 25$, $\phi 32$

Provided with shock absorbers to absorb impact and noise.

The slide unit can absorb energy in a wide range, in high speed, low-load applications to low speed, high-load applications, without requiring adjustments.

Ensures high positional accuracy.

A high level of positional accuracy can be attained because the two parallel piston rods prevent the rods from rotating, and the workpiece mounting surface and the parallelism of the piston rods are made highly precise.

Auto switches can be installed.

Smooth operation and high thrust.

Mountable on the housing or on the plate.

The slide unit can be mounted on the housing or on the plate, depending on the application. It can also be bolted from the bottom or from the top. The piping can be fitted to the port in any of the three positions, according to how the unit is mounted.

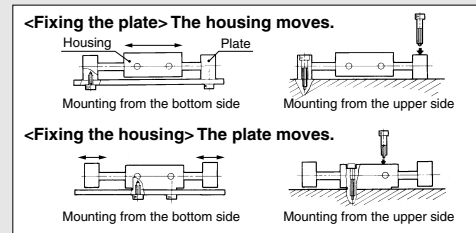

Series Variations

Slide unit	Bearing type	Model	Bore size	Stroke (mm)							Accessory	Auto switch mounting	Page			
				25	50	75	100	125	150	175				200		
Slide bearing	Slide bearing	CX2□ Series Double rod type (Basic type, compact)	$\phi 10$	●	●	●	●	●	●	●	●	(1)	●	650		
			$\phi 15$	●	●	●	●	●	●	●	●	●	●		●	
			$\phi 25$	●	●	●	●	●	●	●	●	●	●		●	
	Ball bushing bearing	Slide bearing	CXWM Series Built-in shock absorber type	$\phi 10$	(2)	●	●	●	●	●	●	●	●	(1)	●	659
				$\phi 16$	(2)	●	●	●	●	●	●	●	●	●	●	
				$\phi 20$	(3)	●	●	●	●	●	●	●	●	●	●	
				$\phi 25$	(2)	●	●	●	●	●	●	●	●	●	●	
				$\phi 32$	(3)	(3)	●	●	●	●	●	●	●	●	●	
				Ball bushing bearing	Slide bearing	CXWL Series Built-in shock absorber type	$\phi 10$	(1)	●	●	●	●	●	●	●	
$\phi 16$	●	●	●				●	●	●	●	●	●	●	●		
$\phi 20$	●	●	●				●	●	●	●	●	●	●	●		
$\phi 25$	●	●	●				●	●	●	●	●	●	●	●		
$\phi 32$	(3)	●	●				●	●	●	●	●	●	●	●		

Note 1) Only type E (Reed switch) is applicable as an auto switch when mounting a housing of $\phi 10$.
 Note 2) The shock absorbers are to be mounted on the both sides for the 25 stroke of the CXWM10 to 25 series.
 Note 3) The shock absorber is to be mounted on one side of the plate for the 25 stroke of the CXWM20, CXWM32, CXWL32 series and the 50 stroke of the CXWM32 series.

With end lock
 Shock absorber
 Adjusting bolt
 Housing mounting
 Plate mounting

- CX2
- CXW
- CXT
- CXSJ
- CXS

- D-□
- X□

CX2/CXWM/CXWL Series

Prior to Use

Maximum Allowable Moment: CX2N, CXWM, CXWL

Operate within the operating range and under the allowable moment indicated in the table below.

- CX2N
- CXWM (Slide bearing)
- - - CXWL (Ball bushing bearing)

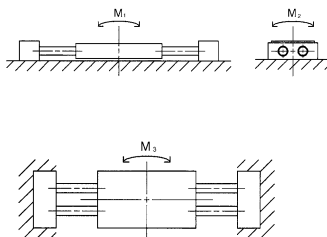
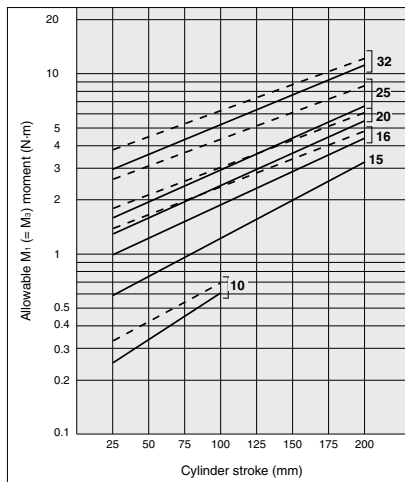

Allowable Moment (M_2) (N-m)

Bore size (mm)	10	15	16	20	25	32
CX2N	0.098	0.294	—	—	1.029	—
CXWM	0.108	—	0.549	0.809	1.029	2.695
CXWL	0.108	—	0.549	0.809	1.201	2.695

Note) M_2 is steady regardless of the strokes.

Allowable Kinetic Energy

Load mass and cylinder speed should be observed within the range given in the graph below. To adjust the cylinder speed, use a speed controller.

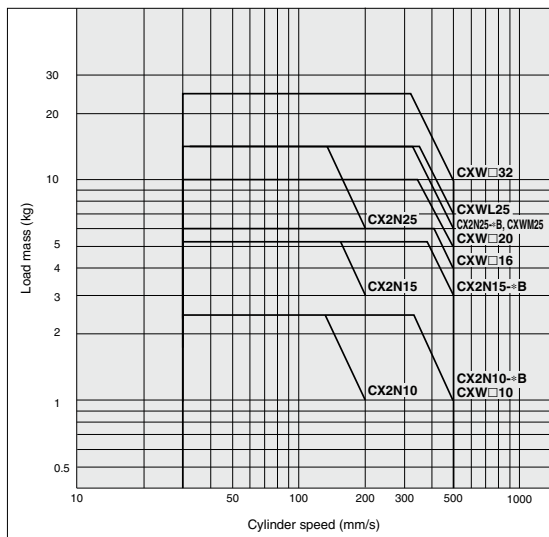

CX2 Series

Prior to Use

1. Changing from the non-auto switch specifications to the auto switch specifications
2. Changing mounting type of the auto switch specifications

CX2 Series

1. In the CX2 series, to change from the specification without auto switch to the plate mounting type with auto switch or to the housing mounting type with auto switch, refer to tables (1) and (2) before ordering.



2. In the CX2 series, to change from the plate mounting type with an auto switch to the housing mounting type with an auto switch or vice versa, refer to tables (1) and (2) before ordering.

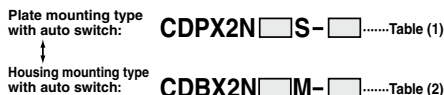

Table (1) Plate Mounting Type with Auto Switch (CDPX2N□□-□)
Component Parts for Mounting Switches and No. of Component Parts

Component parts	Material	ø10	ø15	ø25
		Assembly model no. for mounting switch		
		CDPX2N 10S-□	CDPX2N 15S-□	CDPX2N 25S-□
Switch mounting block	Aluminum alloy	1	1	1
Block mounting screw	Chrome steel/Zinc chromated	2	2	2
Switch mounting screw	Chrome steel/Zinc chromated	2	2	2
Hexagon nut	Carbon steel/Zinc chromated	2	2	2
Magnet	—	1(2) ²⁾	—	—
Socket	Carbon steel/Electroless nickel plated	2	—	—
Plug	Carbon steel/Nickel plated	2	2	—

Note 1) "□" mark indicates strokes.

Note 2) In the case of ø10, the 25 mm stroke has two magnets that are bonded in the holes on the side of the housing. Those with strokes of 50 mm to 100 mm have one magnet. Those with other bore sizes have a built-in magnet in their housings.

Table (2) Housing Mounting Type with Auto Switch (CDBX2N□□-□)
Component Parts for Mounting Switches and No. of Component Parts

Component parts	Material	ø10	ø15	ø25
		Assembly model no. for mounting switch		
		CDBX2N 10M-□	CDBX2N 15M-□	CDBX2N 25M-□
Magnet mounting block assembly	Aluminum alloy	1	1	1
Switch mounting rail	Aluminum alloy	—	1	1
Spacer	Aluminum alloy/Anodized	2	—	—
Block mounting screw	Chrome steel/Zinc chromated	2	2	2
Screw for mounting rail	Chrome steel/Zinc chromated	—	2	2
Switch mounting screw	Chrome steel/Zinc chromated	2	2	2
Hexagon nut	Carbon steel/Zinc chromated	2	2	2
Hexagon socket head plug	Chrome steel/Zinc chromated	2	2	—

Note 1) "□" mark indicates strokes.

Note 2) For ø10, CX2N10-□ can be changed to CDBX2N10-□, but note that CDPX2N10□ cannot be changed to CDBX2N10-□.

CX2

CXW

CXT

CXSJ

CXS

D-□

-X□

Slide Unit/Double Rod Type

CX2 Series

Slide Bearing: $\phi 10, \phi 15, \phi 25$

How to Order

Port thread type

Symbol	Type	Bore size
Nil	M thread	$\phi 10, \phi 15$
	Rc 1/8	
TN	NPT 1/8	$\phi 25$
TF	G 1/8	

Basic type CX2 N 15 [] - 100 B - []

With auto switch C DB X2 N 15 [] - 100 B - J79W [] - []

Cylinder with auto switch

Symbol	Specifications/Mounting
DB	With auto switch/ Housing mounting
DP	With auto switch/ Plate mounting

Type

N	Non-lube type
H	Air-hydro type (Except $\phi 10$)

Bore size/Stroke (mm)

	$\phi 10$	$\phi 15$	$\phi 25$
25, 50, 75, 100			
125, 150, 175, 200			
250, 300			

For $\phi 15$ and $\phi 25$, strokes up to 300 are available as made-to-order. (-XB11)

Auto switch

Nil	Without auto switch (Built-in magnet)	Number of auto switches
S		2 pcs.
n		1 pc.
		"n" pcs.

* For the applicable auto switch model, refer to the table below.

Shock Absorbers

Type	Bore size (mm)		
	10, 15	15	25
Standard (shock absorber RB series)	RB0805		RB1006
Shock absorber soft type RJ series type (-XB22)	RJ0806H		RJ1007H

* The shock absorber service life is different from that of the CX2 cylinder. Refer to "Specific Product Precautions" for each shock absorber for the replacement period.
* The shock absorber soft type RJ series type (-XB22) is a made to order specification. For details, refer to page 1296.

Cushion (Option)

Nil	With adjusting bolt (2 pcs.)
B	With shock absorber (2 pcs.)
BS	With shock absorber (1 pc.)

Applicable Auto Switches/Refer to pages 1119 to 1245 for further information on auto switches.

Type	Special function	Electrical entry	Indicating light	Wiring (Output)	Load voltage		Rail mounting		Applicable cylinder size		Lead wire length (m)				Pre-wired connector	Applicable load		
					DC	AC	Perpendicular	In-line	Housing mounting	Plate mounting	0.5 (Nil)	3 (L)	5 (Z)	None (N)		IC circuit	Relay, PLC	
Solid state auto switch	—	Grommet	Yes	3-wire (NPN)	24 V	5 V, 12 V	—	F7NV	F79	$\phi 15$	$\phi 10$	●	●	○	—	○	Relay, PLC	
				3-wire (PNP)				F7PV	F7P			●	●	○	—	○		
		2-wire	F7BV	J79				●	●			○	—	○				
		J79C	—	—				—	—			—	—					
	Diagnostic indication (2-color indicator)	Grommet	Yes	3-wire (NPN)	24 V	5 V, 12 V	—	F7NWW	F79W	$\phi 25$	$\phi 15$	●	●	○	—	○	Relay, PLC	
				3-wire (PNP)				—	F7PW			●	●	○	—	○		
		2-wire	F7BWW	J79W				●	●			○	—	○				
		4-wire (NPN)	F7BAV**	F7BA**				—	—			—	—	—				
Reed auto switch	—	Grommet	Yes	3-wire	24 V	5 V, 12 V	—	—	A76H	$\phi 15$	$\phi 10$	●	●	○	—	○	Relay, PLC	
				—				A72	A72H			●	●	○	—	○		
		2-wire	A73	A73H				●	●			○	—	○				
		—	A73C	—				●	●			○	—	○				
	Water resistant (2-color indicator)	Grommet	No	3-wire	24 V	5 V, 12 V	24 V or less	—	—	E76A	$\phi 25$	$\phi 15$	●	●	○	—	○	Relay, PLC
				2-wire					E73A	●			●	○	—	○		
		—	A80C	—					●	●			○	—	○			
		—	E76A	—					●	●			○	—	○			
With diagnostic output (2-color indicator)	Grommet	No	3-wire	24 V	5 V, 12 V	100 V or less	—	—	E76A	$\phi 10$	—	●	●	○	—	○	Relay, PLC	
			2-wire					E73A	●			●	○	—	○			
	—	E80A	—					●	●			○	—	○				
	—	E80A	—					●	●			○	—	○				

** Water resistant type auto switches can be mounted on the above models, but in such case SMC cannot guarantee water resistance. Consult with SMC regarding water resistant types with the above model numbers.

* Lead wire length symbols: 0.5 m Nil (Example) F79W
3 m L (Example) F79WL
5 m Z (Example) F79WZ
None N (Example) J79CN

* Refer to pages 1192 and 1193 for details of auto switches with a pre-wired connector.
* Auto switches are shipped together (not assembled).

Specifications

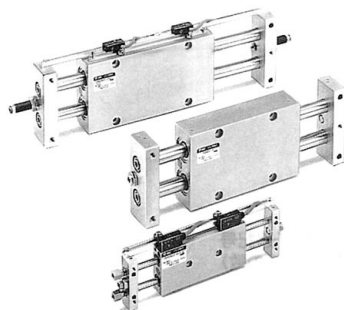

Type		Non-lube	Air-hydro type
Fluid		Air	Hydraulic fluid
Proof pressure		1.5 MPa	
Max. operating pressure		1.0 MPa	
Min. operating pressure	CX2N10	0.15 MPa	—
	CX2□15		0.15 MPa
	CX2□25		0.10 MPa
Ambient and fluid temperature		-10°C to +60°C	
Piston speed (Non-lube)	With adjusting bolt	30 to 200 mm/s	Refer to Table (1).
	With shock absorber	30 to 500 mm/s	
Cushion		With shock absorber (Option)	
Stroke adjustable range		Standard stroke: ±2 mm	
Max. load mass ⁽¹⁾	CX2N10	9.8 N	
	CX2□15	29.4 N	
	CX2□25	58.8 N	
Non-rotating accuracy (Except piston rod deflection)	CX2N10	±0.1°	
	CX2□15	±0.04°	
	CX2□25	±0.02°	
Accessory (Option)		Straight knock pin (2 pcs.), Adjusting bolt (-X138) ⁽²⁾ Shock absorber	

Note 1) Place the center of gravity of the load as close to the center of the slide unit as possible during operation. If they are placed far apart, consult with SMC.

Note 2) "-X138" has a stroke adjustable range of 12.5 mm on one side.



Made to Order: Individual Specifications
(For details, refer to pages 706 to 708.)

Symbol	Specifications
-X138	Adjustable stroke
-X146	Hollow piston rod
-X168	CX helical insert thread
-X169	2 built-in magnets

Made to Order Specifications
(For details, refer to pages 1247 to 1440.)

Symbol	Specifications
-XB11	Long stroke type
-XB13	Low speed cylinder (5 to 50 mm/s)
-XB22	Shock absorber soft type RJ series type
-XC22	Fluororubber seals

Table (1) Air-hydro/Piston Speed

Model	Plate mounting	Housing mounting
CX2H15	Refer to the below. ^{Note 1)}	5 to 50 mm/s
CX2H25	5 to 40 mm/s	5 to 100 mm/s

Note 1) Consult with SMC when the air-hydro type is mounted on a plate.

Note 2) Consult with SMC when units are used at a low speed (10 mm/s or faster) (when intermediate stops are not required) since -XB13 (Low speed specification) is available.

Note 3) When using the air-hydro type, use the double side hydro unit.

Shock Absorber Specifications

Shock absorber		RB0805	RB1006
Applicable slide unit		CX2N10, CX2□15	CX2□25
Maximum energy absorption (J)		0.98	3.92
Stroke absorption (mm)		5	6
Max. collision speed (m/sec)		0.05 to 5	
Max. operating frequency (cycle/min)		80	70
Max. allowable thrust (N)		147	353
Ambient temperature range (°C)		-10 to 80	
Spring force (N)	Extended	1.96	4.22
	Retracted	3.83	6.18
Weight (g)		15	25

* The above shows the maximum absorption energy per cycle. Accordingly, the operating frequency can be increased in accordance with the absorption energy.

* The shock absorber service life is different from that of the cylinder body depending on the operating conditions. Refer to the RB Series Specific Product Precautions for the replacement period.

Theoretical Output

Model	Rod size (mm)	Piston area (mm ²)	Operating pressure (MPa)								(N)
			0.2	0.3	0.4	0.5	0.6	0.7	0.8	0.9	
CX2N10	6	101	20	30	40	51	61	71	81	91	
CX2□15	8	207	41	62	83	104	124	145	166	186	
CX2□25	14	597	119	179	239	299	358	418	478	537	

Note) Theoretical output (N) = Pressure (MPa) x Piston area (mm²)

Moisture Control Tube IDK Series



When operating an actuator with a small diameter and a short stroke at a high frequency, the dew condensation (water droplet) may occur inside the piping depending on the conditions.

Simply connecting the moisture control tube to the actuator will prevent dew condensation from occurring. For details, refer to [the IDK series in the Best Pneumatics No. 6.](#)

CX2

CXW

CXT

CXSJ

CXS

D-□

-X□

CX2 Series

Standard Stroke Table

Model	Basic stroke (mm)							
	25	50	75	100	125	150	175	200
CX2N10	●	●	●	●	—	—	—	—
CX2□15	●	●	●	●	●	●	●	●
CX2□25	●	●	●	●	●	●	●	●

Weight

Model	Basic stroke (mm)							
	25	50	75	100	125	150	175	200
CX2N10	0.17	0.22	0.27	0.32	—	—	—	—
CX2□15	0.23	0.34	0.45	0.56	0.67	0.78	0.89	1.00
CX2□25	0.93	1.15	1.36	1.58	1.80	2.01	2.29	2.45

Operating Direction with Different Pressure Ports

Operating direction of housing when the plate is fixed

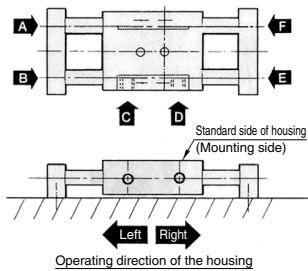

Pressure port	A	B	C	D	E	F
Operating direction	Right	Left	Left	Right	Left	Right

* There are 9 possible reciprocating piping methods.

Deflection of Piston Rod by Center Loading (Reference)

When center loading is added to the center of the housing

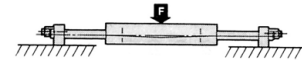

Model	Stroke		
	Load (N)	100	200
CX2N10	9.8	0.07	—
CX2□15	29.4	0.08	0.28
CX2□25	58.8	0.02	0.08

When center loading is added to the center of the plate

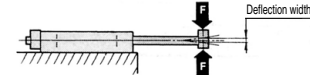

Model	Stroke				
	Load (N)	50	100	150	200
CX2N10	2.94	0.06	0.30	—	—
CX2□15	4.90	0.09	0.22	0.50	1.0
CX2□25	9.81	0.03	0.09	0.16	0.25

Note) The values denote the total width of the deflections in the upward/downward direction.

Accessory Straight Knock Pin (Option)

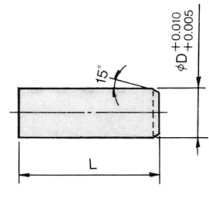

Model	L	øD	Part no.*
CX2N10	10	4	MS4-10
CX2□15	10	5	MS5-10
CX2□25	15	6	MS6-15

* Manufactured by Misumi Trading Ltd.

Construction/Parts List, Seal List

CX2N10

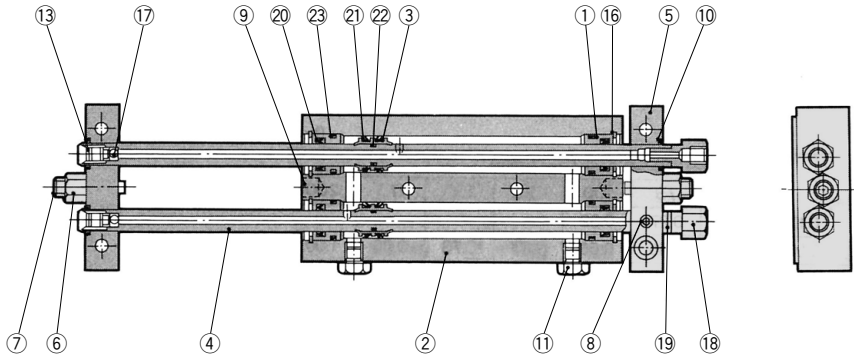

CX2N15, 25

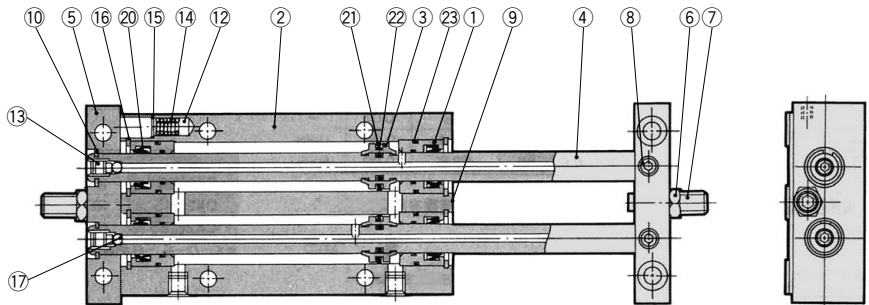

Parts List

No.	Description	Material	Note
1	Rod cover	Aluminum bearing alloy	
2	Housing	Aluminum alloy	Hard anodized
3	Piston	Aluminum alloy	
4	Piston rod	Carbon steel piping for machine constructions	Hard chrome plated
5	Plate	Aluminum alloy	Anodized
6	Lock nut	Carbon steel	Nickel plated
7	Adjusting bolt	Chromium steel	Zinc chromated
8	Set screw (For fixing rods)	Chromium steel	Zinc chromated
9	Pin	Carbon steel	Quenched
10	Retaining ring	Carbon tool steel	Phosphate coated
11	Plug	Carbon steel	Nickel plated
12	Magnet	—	
13	Ball fixing screw	Chromium steel	Zinc chromated
14	Spring	Stainless steel	
15	Type CR retaining ring	Carbon tool steel	
16	Round type R retaining ring	Carbon tool steel	Phosphate coated

Parts List

No.	Description	Material	Note
17	Steel ball	High carbon chrome bearing steel	Heat treated
18	Socket	Brass	Electroless nickel plated
19	Gasket	NBR	
20	Rod seal		
21	Piston seal		
22	Piston gasket		
23	Cylinder tube gasket		

Replacement Parts: Seal Kit

Model	Kit no.	Contents
CX2N10	CX2N10-PS	A set of ⑳, ㉑, ㉒ listed above
CX2N15	CX2N15-PS	
CX2N25	CX2N25-PS	

* Seal kit includes ㉑, ㉒, ㉓. Order the seal kit, based on each bore size. (The piston gasket ㉒ is not replaceable.)

* Since the seal kit does not include a grease pack, order it separately. Grease pack part no.: GR-S-010 (10 g)

CX2

CXW

CXT

CXSJ

CXS

D-□

-X□

CX2 Series

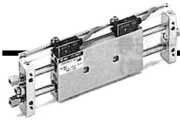

ø10 Basic Type: CX2N10 - Strokes: 25 to 100

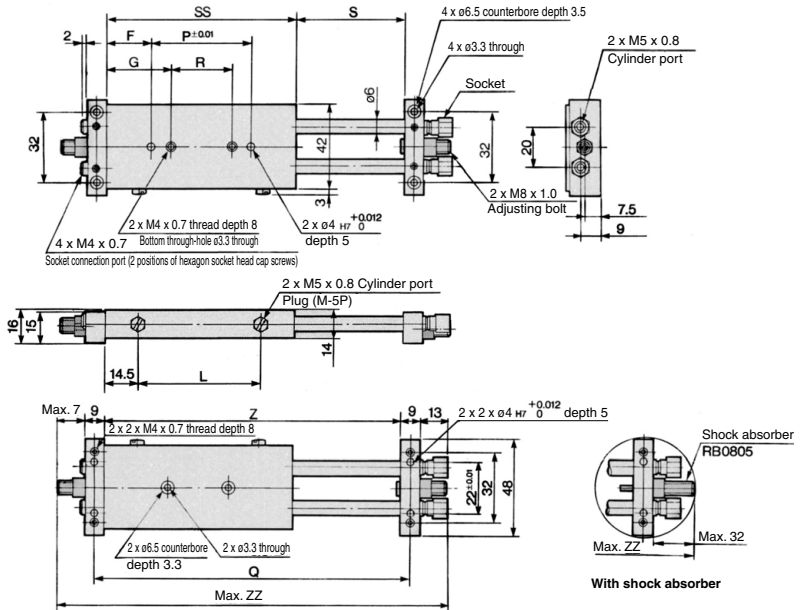

Model	F	G	L	P	Q	R	S	SS	Z	(mm)	
										With adjusting bolt ZZ	With shock absorber ZZ
CX2N10-25	9.5	19.5	38	48	103	28	27	67	94	132	176
CX2N10-50	20	30	63	52	153	32	52	92	144	182	226
CX2N10-75	25	35	88	67	203	47	77	117	194	232	276
CX2N10-100	25	35	113	92	253	72	102	142	244	282	326

Housing mounting type with auto switch

CDBX2N10 - Stroke

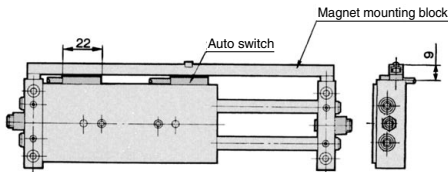

Note 1) The dimensions show D-E7□A and D-E80A.

Plate mounting type with auto switch

CDPX2N10 - Stroke

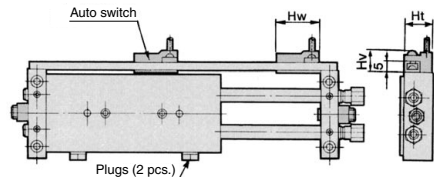

Note 1) The dimensions show D-A7 and D-A8.

Auto switch model	Hw	Ht	Hv
D-A7, D-A8	23	15	10.5
D-F7□, D-J79, D-J79W, D-F7PW, D-F79F, D-F7BA, D-F7NT	23	15	11.5
D-A7□H, D-A80H	22	15	11.5
D-A73C, D-A80C	23	17.5	17.5
D-F7□V	23	15	14
D-J79C	24	17.5	17
D-F7LF	30	15	11.5

Note 2) For only 25 strokes, two magnets for auto switches are installed in the housing.

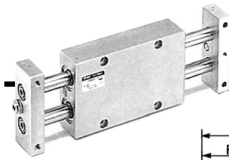

ø15 Basic Type: CX2□15— [Strokes: 25 to 200] □

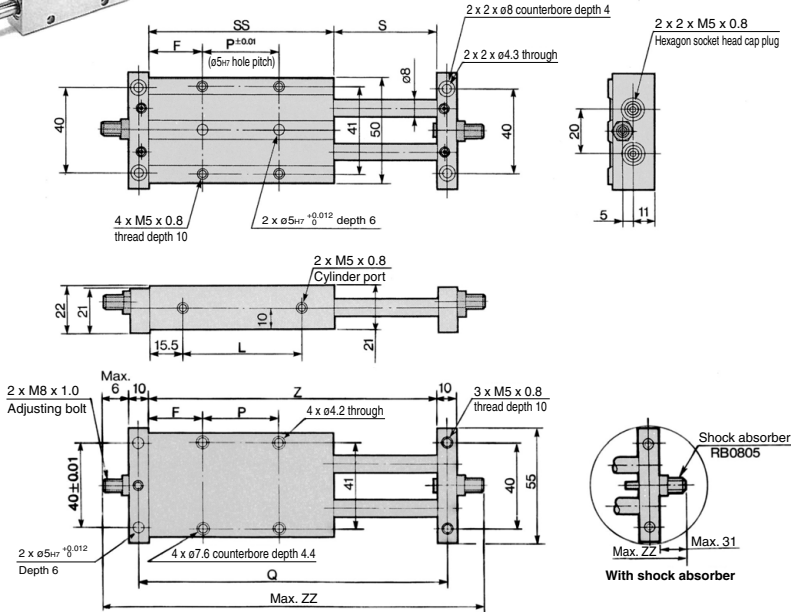

(mm)

Model	F	L	P	Q	S	SS	Z	With adjusting bolt	With shock absorber
								ZZ	ZZ
CX2□15-25□	24.5	38	20	106	27	69	96	128	178
CX2□15-50□	24.5	63	45	156	52	94	146	178	228
CX2□15-75□	27	88	65	206	77	119	196	228	278
CX2□15-100□	27	113	90	256	102	144	246	278	328
CX2□15-125□	39.5	138	90	306	127	169	296	328	378
CX2□15-150□	52	163	90	356	152	194	346	278	428
CX2□15-175□	64.5	188	90	406	177	219	396	428	478
CX2□15-200□	77	213	90	456	202	244	446	478	528

Housing mounting type with auto switch CDBX2□15— [Stroke]

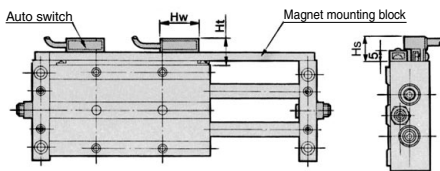

Note 1) The dimensions show D-A7 and D-A8.

Auto switch model	Hw	Hs	Ht
D-A7, D-A8	23	12.5	15
D-F7□, D-J79, D-J79W, D-F7PW, D-F79F, D-F7BA, D-F7NT	23	12.5	15
D-A7□H, D-A80H	22	12.5	15
D-A73C, D-A80C	23	15	17.5
D-F7□V	23	12.5	15
D-J79C	24	15	17.5
D-F7LF	30	12.5	15

Note 2) For only 25 strokes, two magnets for auto switches are installed to the magnet mounting block.

Plate mounting type with auto switch CDPX2□15— [Stroke]

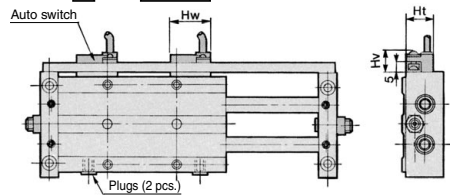

Note 1) The dimensions show D-A7 and D-A8.

Auto switch model	Hw	Ht	Hv
D-A7, D-A8	23	15	10.5
D-F7□, D-J79, D-J79W, D-F7PW, D-F79F, D-F7BA, D-F7NT	23	15	11.5
D-A7□H, D-A80H	22	15	11.5
D-A73C, D-A80C	23	17.5	17.5
D-F7□V	23	15	14
D-J79C	24	17.5	17
D-F7LF	30	15	11.5

Note 2) For only 25 strokes, two magnets for auto switches are installed in the housing.

- CX2**
- CXW**
- CXT**
- CXSJ**
- CXS**

- D-□**
- X□**

CX2 Series

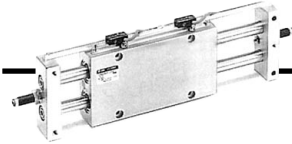

ø25 Basic Type: CX2 □ 25 - Strokes: 25 to 200

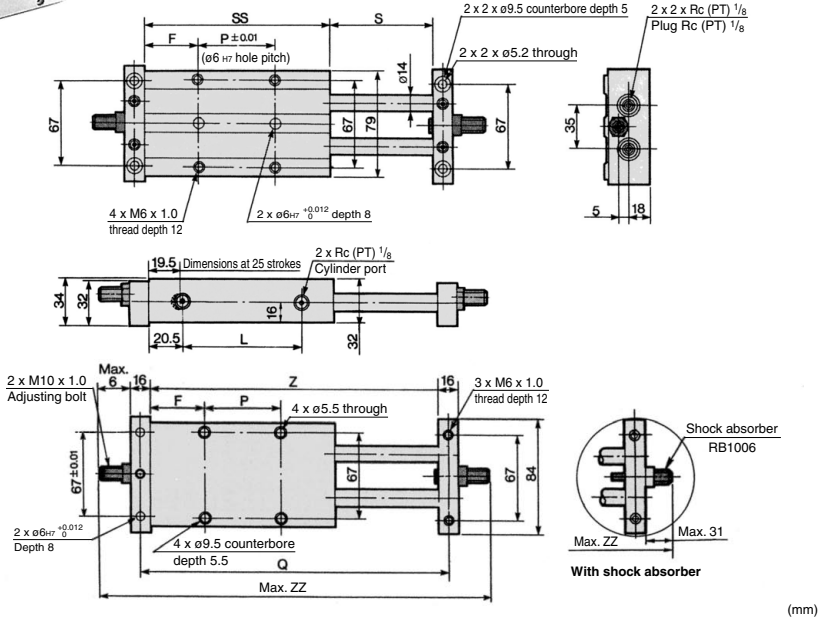

Model	F	L	P	Q	S	SS	Z	With adjusting bolt	With shock absorber
								ZZ	ZZ
CX2□25-25□	28.5	43	25	125	27	82	109	153	203
CX2□25-50□	31	66	45	175	52	107	159	203	253
CX2□25-75□	33.5	91	65	225	77	132	209	253	303
CX2□25-100□	33.5	116	90	275	102	157	259	303	353
CX2□25-125□	46	141	90	325	127	182	309	353	403
CX2□25-150□	58.5	166	90	375	152	207	359	403	453
CX2□25-175□	71	191	90	425	177	232	409	453	503
CX2□25-200□	83.5	216	90	475	202	257	459	503	553

Housing mounting type with auto switch CDBX2 □ 25 - Stroke

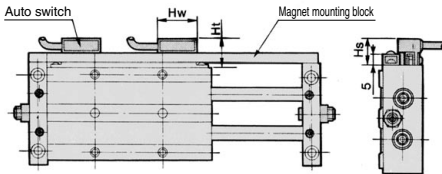

Note 1) The dimensions show D-A7 and D-A8.

Auto switch model	Hw	Hs	Ht
D-A7, D-A8	23	12.5	15
D-F7□, D-J79, D-J79W, D-F7PW, D-F79F, D-F7BA, D-F7NT	23	12.5	15
D-A7□H, D-A80H	22	12.5	15
D-A73C, D-A80C	23	15	17.5
D-F7□V	23	12.5	15
D-J79C	24	15	17.5
D-F7LF	30	12.5	15

Note 2) For only 25 strokes, two magnets for auto switches are installed to the magnet mounting block.

Plate mounting type with auto switch CDPX2 □ 25 - Stroke

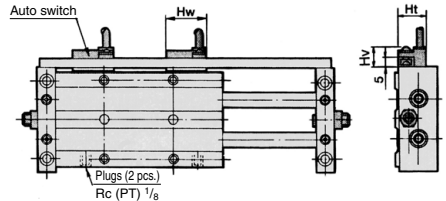

Note 1) The dimensions show D-A7 and D-A8.

Auto switch model	Hw	Ht	Hv
D-A7, D-A8	23	15	10.5
D-F7□, D-J79, D-J79W, D-F7PW, D-F79F, D-F7BA, D-F7NT	23	15	11.5
D-A7□H, D-A80H	22	15	11.5
D-A73C, D-A80C	23	17.5	17.5
D-F7□V	23	15	14
D-J79C	24	17.5	17
D-F7LF	30	15	11.5

Note 2) For only 25 strokes, two magnets for auto switches are installed in the housing.

Operating Range

(mm)

Auto switch model		Applicable cylinder size		
		10	15	25
D-A7□/A80 D-A7□H/A80H D-A73C/A80C	Housing mounting	—	6	6
	Plate mounting	6		
D-E7□A/E80A	Housing mounting	6	—	—
D-F7□/J79 D-F7□V/J79C D-F7□W/F7□WV D-F7BA/F7BAV D-F79F/F7NT	Housing mounting	—	2.5	2.5
	Plate mounting	2.5	2.5	3

* Since the operating range is provided as a guideline including hysteresis, it cannot be guaranteed (assuming approximately $\pm 30\%$ dispersion). It may vary substantially depending on an ambient environment.

Besides the models listed in How to Order, the following auto switches are applicable.
Refer to pages 1119 to 1245 for the detailed specifications.

Auto switch type	Model	Electrical entry (Fetching direction)	Features	Applicable cylinder size	
				Housing mounting	Plate mounting
Solid state	D-F7NT	Grommet (In-line)	With timer	ø15, ø25	ø10, ø15, ø25

* With pre-wired connector is also available for D-F7NT type. For details, refer to pages 1119 and 1193.

* It is impossible to mount solid state auto switches to the housing mounting ø10.

CX2**CXW****CXT****CXSJ****CXS****D-□****-X□**