

Regolatore di flusso con raccordo istantaneo

Serie in acciai inox

Esecuzioni a gomito e universale

Serie AS-FG

Modelli



Modello a gomito

a gomito	Universale	Attacco	Diam. est. tubo applicabile														Diametro applicabile (mm)	
			mm						pollici									
			3.2	4	6	8	10	12	1/8"	5/32"	3/16"	1/4"	5/16"	3/8"	1/2"			
AS12□1FG-M5	AS13□1FG-M5	M5	●	●	●													6, 10, 16, 20
AS22□1FG-01	AS23□1FG-01	R(PT) 1/8	●	●	●	●	●*											20, 25, 32
AS22□1FG-02	AS23□1FG-02	R(PT) 1/4		●	●	●	●											20, 25, 32, 40
AS32□1FG-02	AS33□1FG-02	R(PT) 1/4			●	●	●	●										40, 50, 63
AS32□1FG-03	AS33□1FG-03	R(PT) 3/8			●	●	●	●										40, 50, 63
AS42□1FG-04	AS43□1FG-04	R(PT) 1/2					●	●										63, 80, 100
AS12□1FG-U10/32	AS13□1FG-U10/32	10-32UNF							●	●	●	●						6, 10, 16, 20
AS22□1FG-N01	AS23□1FG-N01	NPT1/8							●	●	●	●	●					20, 25, 32
AS22□1FG-N02	AS23□1FG-N02	NPT1/4								●	●	●	●	●				20, 25, 32, 40
AS32□1FG-N02	AS33□1FG-N02	NPT1/4									●	●	●	●				40, 50, 63
AS32□1FG-N03	AS33□1FG-N03	NPT3/8										●	●	●				40, 50, 63
AS42□1FG-N04	AS43□1FG-N04	NPT1/2												●	●			63, 80, 100

Nota 1) La regolazione in scarico e alimentazione può essere distinta visivamente grazie al simbolo di direzione del flusso situato sul corpo in resina.
 Nota 2) * Solo tipo a gomito

Dati tecnici

Pressione di prova	1.5MPa
Max. Pressione d'esercizio	1MPa
Min. pressione d'esercizio	0.1MPa
Temperatura d'esercizio	-5 ÷ 60°C (senza congelamento)
Numero regolazioni spillo	10 Giri (8 Giri Nota 1))
Materiale tubo <small>Nota 2)</small>	Nylon, nylon morbido, poliuretano, poliuretano morbido

Nota 1) Per i tipi AS12□1FG and AS13□1FG

Nota 2) Porre speciale attenzione alla max. pressione d'esercizio se si usano tubi in nylon morbido o in poliuretano.

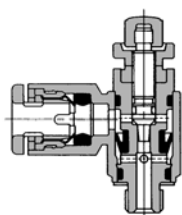

Modello universale

Simbolo JIS

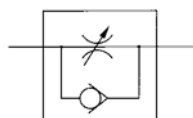

Direzione flusso

	Reg. in scarico	Reg. in alimentazione
Simbolo		
Simbolo		

Fattore di flusso ed area effettiva

Modello	AS12□1FG AS13□1FG	AS22□1FG-□01		AS22□1FG-□02			AS32□1FG			AS42□1FG		
		AS23□1FG-□01	AS23□1FG-□02	AS23□1FG-□02	AS33□1FG	AS33□1FG	AS33□1FG	AS43□1FG	AS43□1FG			
ø est. tubo	mm	ø3.2 ø4 ø6	ø3.2 ø4 ø8 ø10	ø4 ø6 ø8	ø6 ø8 ø10	ø6 ø8 ø10	ø6 ø8 ø10 ø12	ø6 ø8 ø10	ø10 ø12	ø10 ø12		
	pollici	ø1/8" ø5/32" ø3/16" ø1/4"	ø1/8" ø5/32" ø1/4" ø5/16"	ø3/16" ø1/4" ø5/16"	ø5/32" ø3/16"	ø1/4" ø5/16" ø3/8"	ø1/4" ø5/16" ø3/8"	ø1/4" ø5/16" ø3/8"	ø3/8" ø3/8"	ø1/2"		
Controllato (Libero) flusso	Flusso Q_{min} (ANR)	100	180	230	260	390	460	660	790	920	1580	1710
	Sup. effettiva mm ²	1.5	2.7	3.5	4	6	7	10	12	14	12	26

Nota) I valori di flusso si considerano in base ad una pressione di 0.5MPa e ad una temperatura di 20°C.

- AS
- ASN
- AQ
- ASV
- AK
- ASS

Codici di ordinazione

AS **2** **3** **1** **1** **FG** - **01** - **06** **01**

Taglia

1	M5 standard
2	1/8, 1/4 standard
3	3/8 standard
4	1/2 standard

Tipo

2	Modello a gomito
3	Universale

Controllo

0	Regolazione in scarico
1	Regolazione in alimentazione

Con raccordo istantaneo

Acciaio inox (SUS303)

Filettatura

-	Filettatura metrica (M5):
-	Filettatura unica (10-32UNF)
-	R(PT)
N	NPT

Attacco

M5:	M5
U10/32	10-32UNF
01	1/8
02	1/4
03	3/8
04	1/2

Opzione

-	Nessuno
S	Con materiale di tenuta *

* M5 e U10/32 non sono disponibili con materiale di tenuta.

Diam. est. tubo applicabile

mm	pollici
23	ø3.2 *
04	ø4
06	ø6
08	ø8
10	ø10
12	ø12

pollici	mm
01	ø1/8"
03	ø5/32"
05	ø3/16"
07	ø1/4"
09	ø5/16"
11	ø3/8"
13	ø1/2"

* Utilizzare un ø tubo da 1/8".

Valvola a spillo/Caratteristiche di flusso

AS12□1FG
AS13□1FG

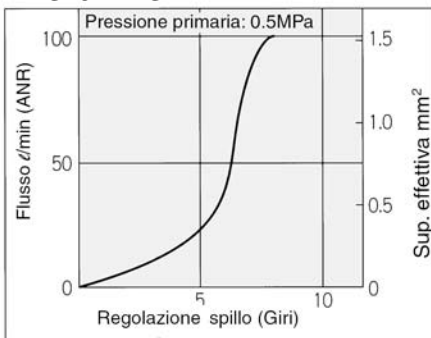

AS22□1FG-□01
AS23□1FG-□01

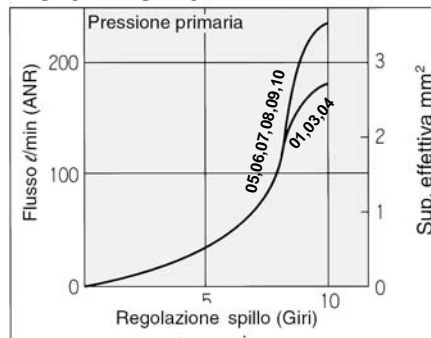

AS22□1FG-□02
AS23□1FG-□02

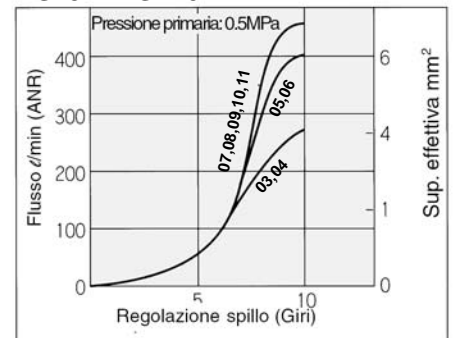

AS32□1FG
AS33□1FG

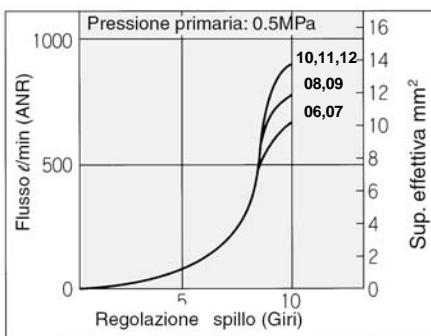

AS42□1FG
AS43□1FG

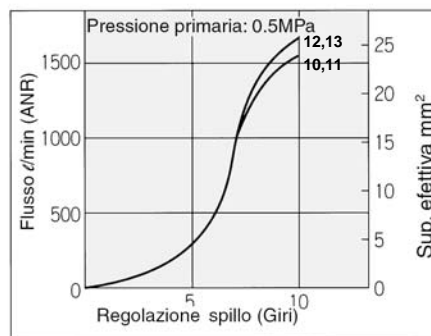

Costruzione/Esec. a gomito

Regolazione in scarico

Tipo M5

Tipo U10/32

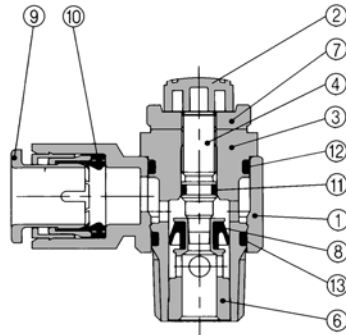
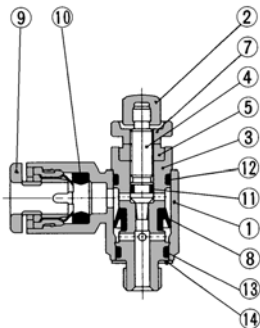

AS3201FG-02

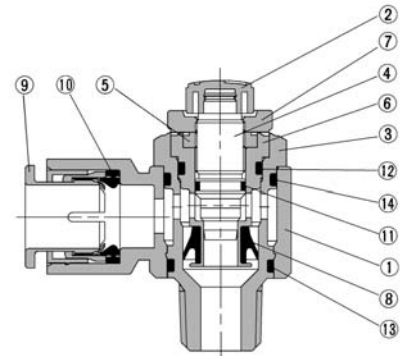

Regolazione in alimentazione

Tipo M5

Tipo U10/32

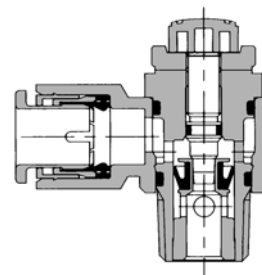
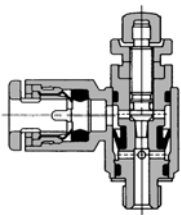

AS3211FG-02

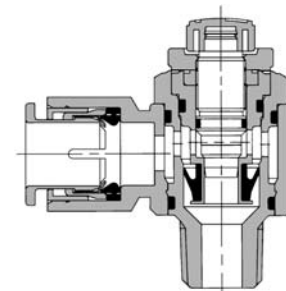

Componenti

N.	Descrizione	Materiale	Nota
1	Corpo A	PBT	
2	Manopola	PBT	
3	Corpo B	SUS303	
4	Spillo	SUS303	
5	Guida spillo	SUS303	
6	Anello	SUS303	
7	Dado bloccaggio	SUS303	
8	Guarnizione a U	NBR	
9	Cassetta	POM, Acciaio inox	
10	Tenuta	NBR	
11	O ring	NBR	
12	O ring	NBR	
13	O ring	NBR	
14	O ring	NBR	
15	Guarnizione	NBR/SUS304	solo tipo M5

AS

ASN

AQ

ASV

AK

ASS

Serie AS-FG

Costruzione/Esec. universale

Regolazione in scarico

Tipo M5

Tipo U10/32

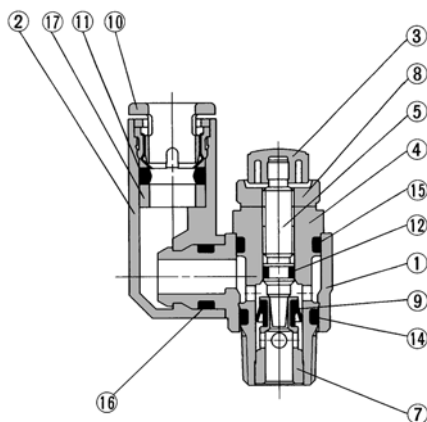
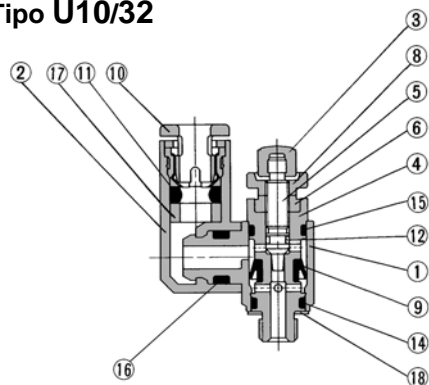

AS3301FG-02

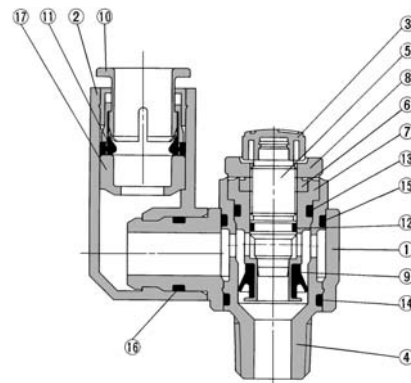

Regolazione in alimentazione

Tipo M5

Tipo U10/32

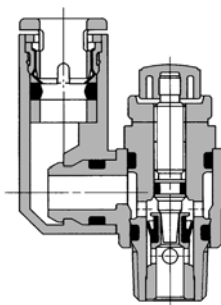
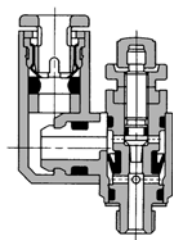

AS3311FG-02

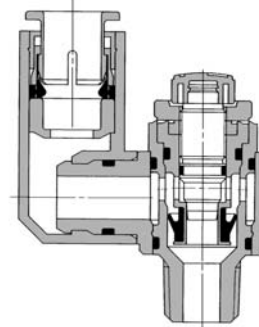

Componenti

N.	Descrizione	Materiale	Nota
1	Corpo A	PBT	
2	A gomito	PBT	
3	Manopola	PBT	
4	Corpo B	SUS303	
5	Spillo	SUS303	
6	Guida spillo	SUS303	
7	Anello	SUS303	
8	Dado bloccaggio	SUS303	
9	Guarnizione a U	NBR	
10	Cassetta	POM, Acciaio inox	
11	Tenuta	NBR	
12	O ring	NBR	
13	O ring	NBR	
14	O ring	NBR	
15	O ring	NBR	
16	O ring	NBR	
17	Distanziale	POM (Nota 1)	
18	Guarnizione	Acciaio inox, NBR	

Nota 1) $\varnothing 3/16''$, $\varnothing 3/8''$ sono $\varnothing 1/2''$ sono SUS303.

Dimensioni/Esec. a gomito

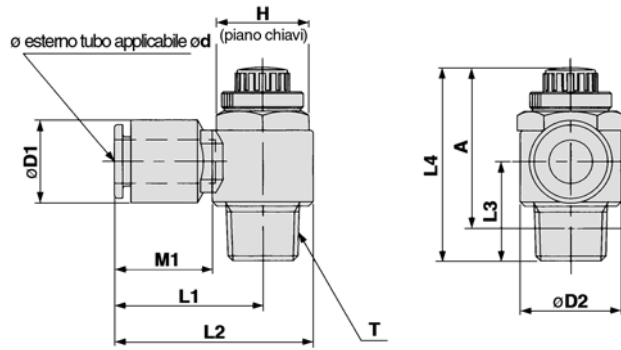

Tipo M5
Tipo U10/32

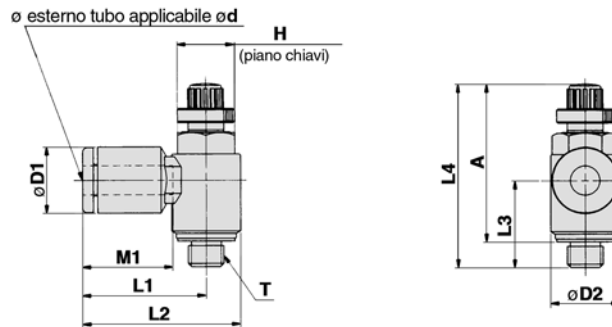

(mm)

Modello	d	T	H	D1	D2	L1	L2	L3	L4		A*		M1	Peso g	
									Max.	Min.	Max.	Min.			
AS12□1FG-M5-23	3.2	M5	8	8.4	9.6	17.3	22.1	12.3	28.6	25.8	25	22.2	12.7	7	
AS22□1FG-01-23	3.2	R(PT)1/8	12	9.3	14.2	20.4	27.5	14.3	36.1	31.1	32.1	27.1	12.7	16	
AS12□1FG-M5-04	4	M5	8	9.3	9.6	17.3	22.1	12.3	28.6	25.8	25	22.2	12.7	7	
AS12□1FG-M5-06	6			11.6		18.1	22.9	11.7							13.5
AS22□1FG-01-04	4	R(PT)1/8	12	9.3	14.2	20.4	27.5	14.3	36.1	31.1	32.1	27.1	12.7	17	
AS22□1FG-01-06	6			11.6		20.4	27.5						13.5		
AS22□1FG-01-08	8			15.2		25.3	32.4						18.5		19
AS22□1FG-01-10	10	18.5	33.1	40.2	21	21									
AS22□1FG-02-04	4	R(PT)1/4	17	10.4	18.5	25.2	34.4	18.2	40.4	35.4	34.4	29.4	16	32	
AS22□1FG-02-06	6			12.8		25.2	34.4						17		
AS22□1FG-02-08	8			15.2		27.2	36.4						18.5		34
AS22□1FG-02-10	10	18.5	33.9	43.2	21	36									
AS32□1FG-02-06	6	R(PT)1/4	19	12.8	23	27.8	39.3	21.8	48.8	43.8	42.8	37.8	17	60	
AS32□1FG-02-08	8			15.2		29.5	41						18.5		63
AS32□1FG-02-10	10			18.5		31.8	43.3						21		67
AS32□1FG-02-12	12	20.9	32.8	44.3	22	69									
AS32□1FG-03-06	6	R(PT)3/8	19	12.8	23	27.8	39.3	20.9	46.5	41.5	40.2	35.2	17	55	
AS32□1FG-03-08	8			15.2		29.5	41						18.5		57
AS32□1FG-03-10	10			18.5		31.8	43.3						21		59
AS32□1FG-03-12	12	20.9	32.8	44.3	22	61									
AS42□1FG-04-10	10	R(PT)1/2	24	18.5	28.6	33.6	47.9	25.4	57.6	50.1	49.6	42.1	21	100	
AS42□1FG-04-12	12	20.9	34.6	48.9		22	101								

* Dimensioni di riferimento per filettatura dopo l'installazione.

pollici

Modello	d	T	H	D1	D2	L1	L2	L3	L4		A*		M1	Peso g	
									Max.	Min.	Max.	Min.			
AS12□1FG-U10/32-01	1/8"	10-32UNF	8	8.4	9.6	17.3	22.1	12.3	28.6	25.8	25	22.2	12.7	7	
AS12□1FG-U10/32-03	5/32"			9.3		20.4	27.5	13.5							
AS12□1FG-U10/32-05	3/16"			11.4		21.3	26.1	11.7							16.5
AS12□1FG-U10/32-07	1/4"			12		18.3	23.1	13.5							
AS22□1FG-N01-01	1/8"	NPT 1/8	12.7	9.3	14.2	20.4	27.5	14.3	36.1	31.1	32.1	27.1	12.7	16	
AS22□1FG-N01-03	5/32"			11.4		23.1	30.2						13.5		
AS22□1FG-N01-05	3/16"			13.2		23.9	31						18.5		19
AS22□1FG-N01-07	1/4"	15.2	25.3	32.4	21	21									
AS22□1FG-N01-09	5/16"	15.2	25.3	32.4	21	21									
AS22□1FG-N02-03	5/32"	NPT 1/4	17.5	10.4	18.5	25.2	34.4	18.2	40.4	35.4	34.4	29.4	16	32	
AS22□1FG-N02-05	3/16"			11.4		24.9	34.2						17		
AS22□1FG-N02-07	1/4"			13.2		25.2	34.5						18.5		34
AS22□1FG-N02-11	3/8"	15.2	27.2	36.4	21	36									
AS22□1FG-N02-09	5/16"	17.9	33.9	43.2	20	36									
AS32□1FG-N02-07	1/4"	NPT 1/4	19	13.2	23	27.8	39.3	21.8	48.8	43.8	42.8	37.8	17	60	
AS32□1FG-N02-09	5/16"			15.2		29.5	41						18.5		63
AS32□1FG-N02-11	3/8"			17.9		31.8	43.3						21		67
AS32□1FG-N03-07	1/4"	NPT 3/8	19	13.2	23	27.8	39.3	20.9	46.5	41.5	40.2	35.2	17	55	
AS32□1FG-N03-09	5/16"			15.2		29.5	41						18.5		57
AS32□1FG-N03-11	3/8"			17.9		31.8	43.3						21		59
AS42□1FG-N04-11	3/8"	NPT 1/2	23.8	17.9	28.6	33.6	47.9	25.4	57.6	50.1	49.6	42.1	21	100	
AS42□1FG-N04-13	1/2"			21.7		35.2	49.5						22		101

* Dimensioni di riferimento per filettature 10-32UNF e NPT dopo installazione.

- AS
- ASN
- AQ
- ASV
- AK
- ASS

Serie AS-FG

Dimensioni/Esec. universale

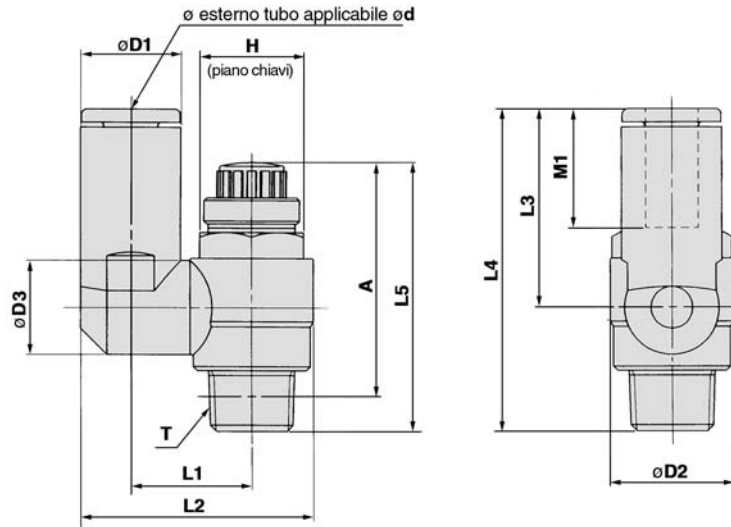

Per tipo M5
Per tipo U10/32

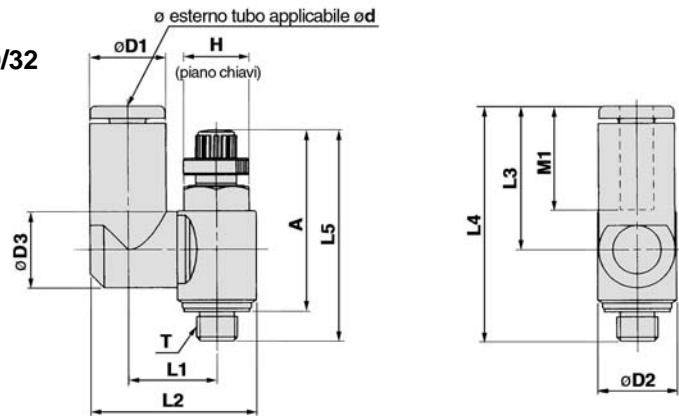

(mm)

Modello	d	T	H	D1	D2	D3	L1	L2	L3	L4	L5		A *		M1	Peso g	
											Max.	Min.	Max.	Min.			
AS13□1FG-M5-23	3.2			8.4				19.8									
AS13□1FG-M5-04	4	M5	8	9.3	9.6	9.3	10.8	20.3	17.5	28.7		28.6	25.8	25	22.2	12.7	7
AS13□1FG-M5-06	6			11.6				21.4	20.6	31.8						13.5	
AS23□1FG-01-23	3.2			8.4				24.4								12.7	17
AS23□1FG-01-04	4			9.3		9.3	13.1	24.9	17.5	31.8						13.5	18
AS23□1FG-01-06	6	R(PT)	12	11.6		14.2		26.9	22.9	37.2		36.1	31.1	32.1	27.1	13.5	18
AS23□1FG-01-08	8	1/8		15.2		12.9	16.2	30.9	28.2	41.7						18.5	21
AS23□1FG-02-04	4			10.4		10.9	16.2	30.6	21.9	40.1						16	32
AS23□1FG-02-06	6			12.8		18.4	34	25.2	42.6			40.4	35.4	34.4	29.4	17	33
AS23□1FG-02-08	8	R(PT)	17	15.2		18.5		28.2	45.6							18.5	36
AS23□1FG-02-10	10	1/4		18.5		20.2	38.7	31	48.4							21	40
AS33□1FG-02-06	6			12.8		12.9	20.6	38.5	25.2	47						17	60
AS33□1FG-02-08	8			15.2		23		39.7	28.2	50						18.5	63
AS33□1FG-02-10	10			18.5		23		43.7	32.6	54.4		48.8	43.8	42.8	37.8	21	67
AS33□1FG-02-12	12	R(PT)	19	20.9		16.2	23	44.9	34.4	56.2						22	69
AS33□1FG-03-06	6			12.8		12.9	20.6	38.5	25.2	46.1						17	56
AS33□1FG-03-08	8			15.2		23		39.7	28.2	49.1						18.5	59
AS33□1FG-03-10	10			18.5		23		43.7	32.6	53.5		46.5	41.5	40	35	21	63
AS33□1FG-03-12	12	R(PT)	3/8	20.9		16.2	23	44.9	34.4	55.3						22	65
AS43□1FG-04-10	10			18.5		25.8	49.4	32.6	58							21	104
AS43□1FG-04-12	12	R(PT)	1/2	20.9	28.6	19.4	26.8	52	36.3	61.7		57.6	50.1	49.6	42.1	22	105

* Le dimensioni di riferimento della filettatura M5 X 0.8, R(PT) dopo installazione.

pollici

Modello	d	T	H	D1	D2	D3	L1	L2	L3	L4	L5		A *		M1	peso g		
											Max.	Min.	Max.	Min.				
AS13□1FG-U10/32-01	1/8"			8.4				19.8										
AS13□1FG-U10/32-03	5/32"			9.3				20.3	17.5	28.7						12.7	7	
AS13□1FG-U10/32-05	3/16"			11.4		9.6	9.3	10.8	21.3	23.3	34.5					16.5		
AS13□1FG-U10/32-07	1/4"			12					21.6	20.7	31.9					13.7	8	
AS23□1FG-N01-01	1/8"			8.4				9.3	13.1	24.4						12.7	17	
AS23□1FG-N01-03	5/32"			9.3				10.9	14	24.9	17.5	31.8				13.5	18	
AS23□1FG-N01-05	3/16"			11.4				12.7	11.4	14						16.5	18	
AS23□1FG-N01-07	1/4"			13.2				10.9	14	26.8	23.9	36.1	31.1	32.1	27.1	18.5	19	
AS23□1FG-N01-09	5/16"			15.2				12.9	16.2	30.9	28.2	41.7				21	21	
AS23□1FG-N02-03	5/32"			10.4				10.9	16.2	30.6	21.9	40.1				16	32	
AS23□1FG-N02-05	3/16"			11.4				12.9	16.2	31.1	23.9	42.6				17	33	
AS23□1FG-N02-07	1/4"			13.2				17.5	13.2	19			40.4	35	34.4	29.4	18.5	36
AS23□1FG-N02-09	5/16"			15.2				12.9	18.3	35.2	28.2	48.4				21	39	
AS23□1FG-N02-11	3/8"			17.9				20.2	38.7	31	47					21	40	
AS33□1FG-N02-07	1/4"			13.2				12.9	20.6	38.7	25.6	46.1				17	60	
AS33□1FG-N02-09	5/16"			15.2				15.2	23	39.7	28.2	54.4	48.8	43.8	42.8	37.8	18.5	63
AS33□1FG-N02-11	3/8"			17.9				16.2	23	43.7	32.6	56.2				21	69	
AS33□1FG-N03-07	1/4"			13.2				12.9	20.6	38.7	25.6	46.1				17	56	
AS33□1FG-N03-09	5/16"			15.2				15.2	23	39.7	28.2	49.1	46.5	41.5	40.2	35.2	18.5	59
AS33□1FG-N03-11	3/8"			17.9				16.2	23	43.7	32.6	53.5				21	65	
AS43□1FG-N04-11	3/8"			17.9				16.2	25.8	49.4	32.6	55.3				21	104	
AS43□1FG-N04-13	1/2"			21.7				19.4	26.8	52	36.3	58	57.6	50.1	49.6	42.1	22	106

* Dimensioni di riferimento per filettature 10-32UNF e NPT dopo installazione.