

IB IL 24 DI 16

INTERBUS Inline Terminal With 16 Digital Inputs

Data Sheet 5553A

07/1999

5553A001

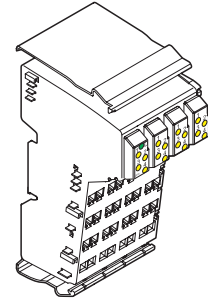

This data sheet is intended to be used in conjunction with the "INTERBUS Inline System Manual" IB IL SYS PRO UM E (Order No. 27 43 04 8).

Function

This terminal is used to accept 24 V digital input signals from sourcing devices.

Features

- Connections for 16 digital sensors
- Connection of 2- and 3-wire sensors
- Maximum permissible load current per sensor: 250 mA
- Maximum permissible load current from the terminal: 4.0 A
- Diagnostic and status indicators

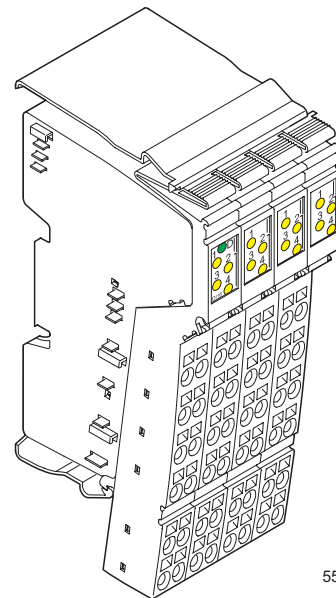

5553A002

Figure 1 IB IL 24 DI 16 terminal with the connectors plugged in



Please note that the connectors are not supplied with the terminal. Refer to the "Ordering Data" Table at the end of this data sheet to choose the appropriate connectors for your application.

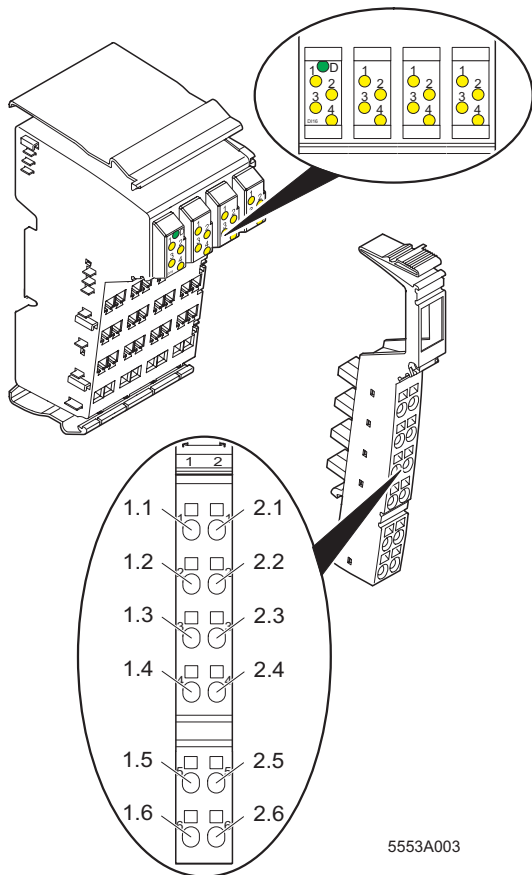

5553A003

Figure 2 IB IL 24 DI 16 terminal with an appropriate connector

Local Diagnostic and Status Indicators

Des.	Color	Meaning
D	Green	Bus diagnostics
Each connector		
1, 2, 3, 4	Yellow	Status indication of the inputs

Terminal Assignment for Each Connector

Terminal Point	Assignment
1.1, 2.1	Signal input (IN)
1.2, 2.2	Segment voltage U_S for 2- and 3-wire termination
1.3, 2.3	Ground contact (GND) for 3-wire termination
1.4, 2.4	Signal input (IN)
1.5, 2.5	Segment voltage U_S for 2- and 3-wire termination
1.6, 2.6	Ground contact (GND) for 3-wire termination



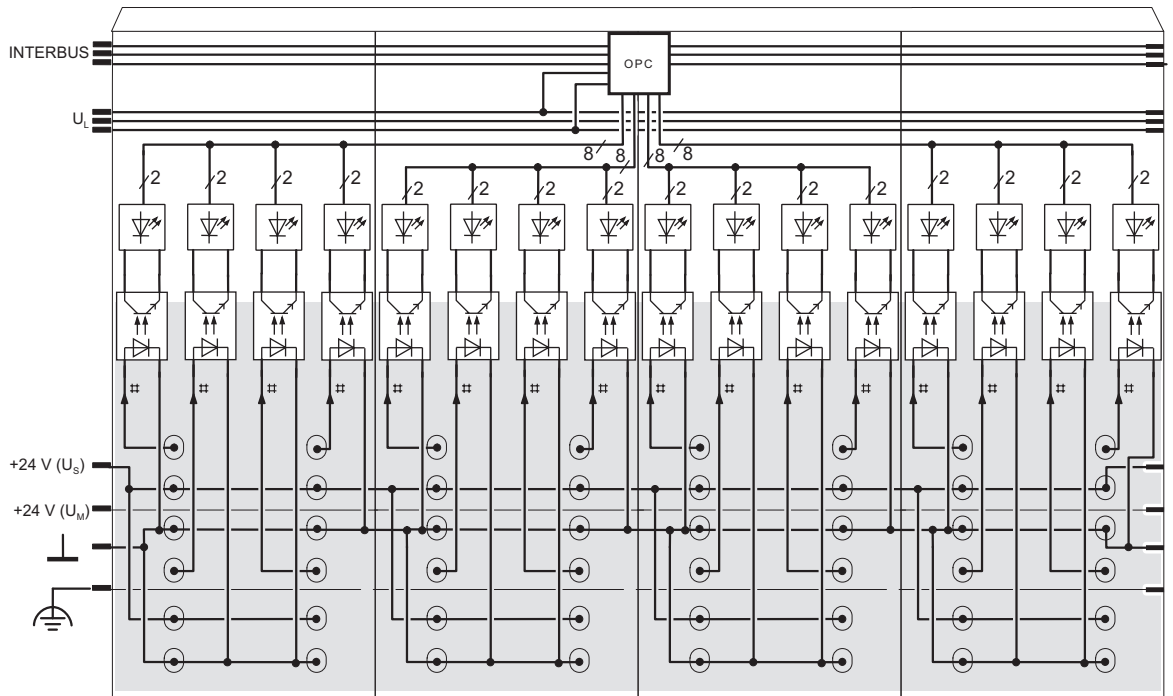

Internal Circuit Diagram



55523003

Figure 3 Internal wiring of the terminal points

Key:

-  INTERBUS protocol chip (bus logic including voltage conditioning)
-  LED (status indicators)
-  Optocoupler
-  Digital input
-  Isolated area



Other symbols are explained in the IB IL SYS PRO UM E User Manual.

Connection Example



When connecting the sensors, observe the assignment of the terminal points to the INTERBUS reference (see page 5).

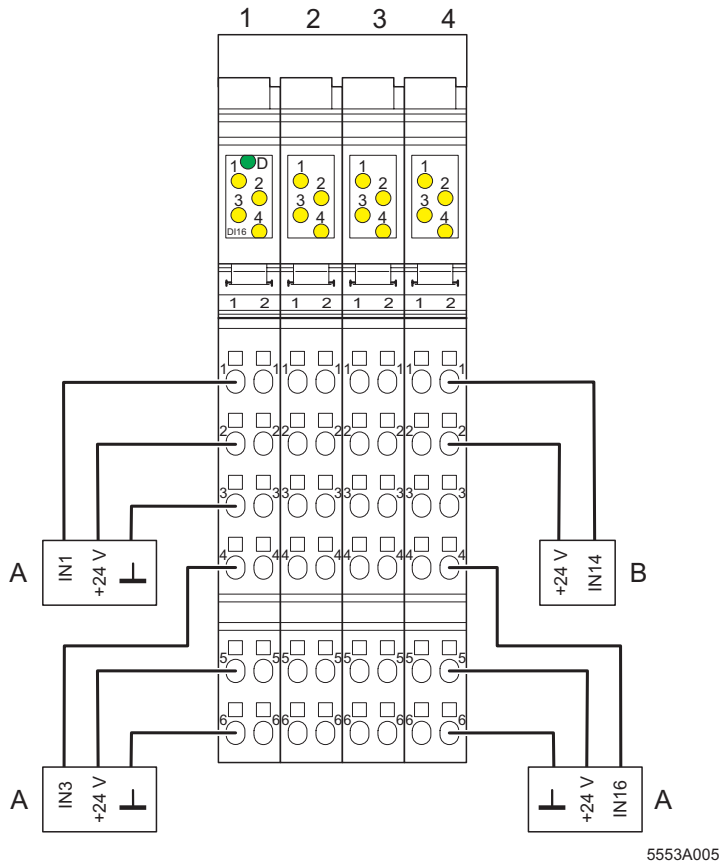

Figure 4 Typical sensor connections

- A 3-wire termination
- B 2-wire termination

The numbers shown above the terminal indicate the mounting locations of the connectors.

Programming Data

ID code	BE _{hex} (190 _{dec})
Length code	01 _{hex}
Input address area	2 bytes
Output address area	0 bytes
Parameter channel (PCP)	0 bytes
Register length (bus)	2 bytes

INTERBUS Process Data Words



Assignment of the Terminal Points to the Process Data Input Word

INTERBUS reference	Word	Word 0															
	Bit	15	14	13	12	11	10	9	8	7	6	5	4	3	2	1	0
(Byte.bit) view	Byte	Byte 0								Byte 1							
	Bit	7	6	5	4	3	2	1	0	7	6	5	4	3	2	1	0
Module	Slot	4				3				2				1			
	Terminal point (signal)	2.4	1.4	2.1	1.1	2.4	1.4	2.1	1.1	2.4	1.4	2.1	1.1	2.4	1.4	2.1	1.1
	Terminal point (+24 V)	2.5	1.5	2.2	1.2	2.5	1.5	2.2	1.2	2.5	1.5	2.2	1.2	2.5	1.5	2.2	1.2
	Terminal point (GND)	2.6	1.6	2.3	1.3	2.6	1.6	2.3	1.3	2.6	1.6	2.3	1.3	2.6	1.6	2.3	1.3
Status indication	Slot	4				3				2				1			
	LED	4	3	2	1	4	3	2	1	4	3	2	1	4	3	2	1



The process data output word is not used.

Technical Data

General	
Housing dimensions (width x height x depth)	48.8 mm x 120 mm x 71.5 mm (1.921 in. x 4.724 in. x 2.815 in.)
Weight	122 g (without connectors)
Operating mode	Process data operation with 2 bytes
Connection type of the sensors	2- and 3-wire technology
Permissible temperature (operation)	-25°C to +55°C (-13°F to +131°F)
Permissible temperature (storage/transport)	-25°C to +85°C (-13°F to +185°F)
Permissible humidity (operation)	75% on average, 85% occasionally
 Ranging from -25°C to +55°C (-13°F to +131°F) appropriate measures against increased humidity (> 85%) must be taken.	
Permissible humidity (storage/transport)	75% on average, 85% occasionally
 For a short period, slight condensation may appear on the housing if, for example, the terminal is brought into a closed room from a vehicle.	
Permissible air pressure (operation)	80 kPa to 106 kPa (up to 2000 m [6562 ft.] above sea level)
Permissible air pressure (storage/transport)	70 kPa to 106 kPa (up to 3000 m [9843 ft.] above sea level)
Degree of protection	IP 20 according to IEC 60529
Class of protection	Class 3 according to VDE 0106, IEC 60536
Interface	
INTERBUS interface	Through data routing
Power Consumption	
Communications power	7.5 V
Current consumption from the local bus	60 mA, maximum
Power consumption from the local bus	0.45 W, maximum
Segment supply voltage U_S	24 V DC (nominal value)
Nominal current consumption of U_S	4 A, maximum

Supply of the Module Electronics and I/O Through Bus Terminal/Power Terminal

Connection method	Through potential routing
-------------------	---------------------------

Digital Inputs

Number	16
Input design	According to EN 61131-2 Type 1
Definition of switching thresholds	
Maximum low level voltage	$U_{Lmax} < 5 \text{ V}$
Minimum high level voltage	$U_{Hmin} > 15 \text{ V}$
Common potentials	Segment supply, ground
Nominal input voltage U_{IN}	24 V DC
Permissible range	$-30 \text{ V} < U_{IN} < +30 \text{ V DC}$
Nominal input current U_{IN}	3 mA, minimum
Delay time	None
Permissible cable length to the sensor	30 m (98.4 ft.) (to ensure conformance with EMC directive 89/336/EEC)
Use of AC sensors	AC sensors in the voltage range $< U_{IN}$ are limited in application. (corresponding to the input design)

Characteristic Curve: Current Depending on the Input Voltage and the Ambient Temperature T_U

Supply voltage	Input current	Input current after $t \geq 20 \text{ s}$	
		At $T_U = 25^\circ\text{C} (77^\circ\text{F})$	At $T_U = 55^\circ\text{C} (131^\circ\text{F})$
18 V	3.0 mA	2.9 mA	2.5 mA
24 V	3.9 mA	3.8 mA	3.5 mA
30 V	4.5 mA	4.2 mA	3.0 mA

The current is reduced depending on the ambient temperature T_U and the number of inputs that are switched on (internal terminal temperature).

Power Dissipation	
<p>Formula to calculate the power dissipation of the electronics</p> $P_{\text{tot}} = 0.525 \text{ W} + \sum_{n=0}^{16} [U_{\text{INn}} \times 0.003 \text{ A}]$ <p>With P_{tot} Total power dissipation of the terminal n Index of the number of set inputs $n = 0$ to 16 U_{INn} Input voltage of the input n</p>	
<p>Power dissipation of the housing P_{HOU}</p>	<p>2.8 W, maximum (within the permissible operating temperature)</p>

Concurrent Channel Derating	
<p>Derating</p>	<p>No limitation of the channel simultaneity. All outputs can be on at maximum current without exceeding housing maximum power dissipation.</p>

Safety Devices	
<p>Overload in segment circuit</p>	<p>No</p>
<p>Surge voltage</p>	<p>Protective circuits of the power terminal</p>
<p>Polarity reversal</p>	<p>Protective circuits of the power terminal</p>

Electrical Isolation	
	To provide electrical isolation between the logic level and the I/O area, it is necessary to supply the bus terminal and this digital input terminal from separate power supply units. Interconnection of the 24 V power supplies is not allowed! (For detailed information refer to the user manual.)
Common potentials	
24 V I/O voltage, 24 V segment voltage, and GND have the same potential. FE (functional earth ground) is a separate potential area.	
Separate system potentials consisting of bus terminal/power terminal and I/O terminal	
- Test distance	- Test voltage
5 V supply incoming remote bus / 7.5 V supply (bus logic)	500 V AC, 50 Hz, 1 min.
5 V supply outgoing remote bus / 7.5 V supply (bus logic)	500 V AC, 50 Hz, 1 min.
7.5 V supply (bus logic) / 24 V supply (I/O)	500 V AC, 50 Hz, 1 min.
24 V supply (I/O) / functional earth ground	500 V AC, 50 Hz, 1 min.
Error Messages to the Higher-Level Control or Computer System	
None	

Ordering Data

Description	Order Designation	Order No.
Terminal with 16 digital inputs	IB IL 24 DI 16	27 26 23 0
 You need 4 connectors for the DI 16 terminal.		
Connector with 12 terminal points using the spring-clamp method (green, w/o color print); pack of 10	IB IL SCN-12	27 26 34 0
Connector with 12 terminal points using the spring-clamp method (green, with color print); pack of 10	IB IL SCN-12-ICP	27 27 61 1
"INTERBUS Inline System Manual"	IB IL SYS PRO UM E	27 43 04 8

Phoenix Contact GmbH & Co.
Flachsmarktstr. 8
32825 Blomberg
Germany

 + 49 - (0) 52 35 - 3-00

 + 49 - (0) 52 35 - 3-4 12 00

 www.phoenixcontact.com