

**JUMO GmbH & Co. KG**  
 Delivery address: Mackenrodtstraße 14,  
 36039 Fulda, Germany  
 Postal address: 36035 Fulda, Germany  
 Phone: +49 661 6003-0  
 Fax: +49 661 6003-607  
 e-mail: mail@jumo.net  
 Internet: www.jumo.net

**JUMO Instrument Co. Ltd.**  
 JUMO House  
 Temple Bank, Riverway  
 Harlow, Essex CM 20 2TT, UK  
 Phone: +44 1279 635533  
 Fax: +44 1279 635262  
 e-mail: sales@jumo.co.uk  
 Internet: www.jumo.co.uk

**JUMO PROCESS CONTROL INC.**  
 885 Fox Chase, Suite 103  
 Coatesville PA 19320, USA  
 Phone: 610-380-8002  
 1-800-554-JUMO  
 Fax: 610-380-8009  
 e-mail: info@JumoUSA.com  
 Internet: www.JumoUSA.com



# JUMO dTRANS T01 / T01T

## Programmable 2-wire transmitter

for connection to resistance thermometers and thermocouples  
 for installation in: terminal head Form B to DIN 43 729  
 for mounting on: rail



### Brief description

The 2-wire transmitter uses resistance thermometers or thermocouples to acquire the temperature. With resistance thermometers, the probe can be connected in 2-/3- or 4-wire circuit. The versions 707015/... and 707016/... are intended for installation inside the hazardous area.

Probe type, connection circuit and range can be configured using the setup program. The 4 – 20mA output signal (or reversed 20 – 4mA) is available in linearized form (linear with temperature).

The instrument is designed for industrial application and conforms to the corresponding European Standards, to ensure electromagnetic compatibility (EMC).

The versions 707015/... and 707016/... conform to the Directives of EN 50 014, and to EN 50 020 "Electrical apparatus for use in hazardous areas" according to the Certificate of Conformity.

The transmitters JUMO dTRANS T01 (Types 707011/..., 707013/... and 707016/...) can also be programmed using a HART® communicator or a HART® modem in conjunction with a PC setup program.



Type 707010/..., Type 707011/... (HART®)  
 Type 707015/... (Ex), Type 707016/... (HART® / Ex)



Type 707012/..., Type 707013/... (HART®)

### System diagrams

Connection example (Types 707010/... to 707013/...) with power supply unit

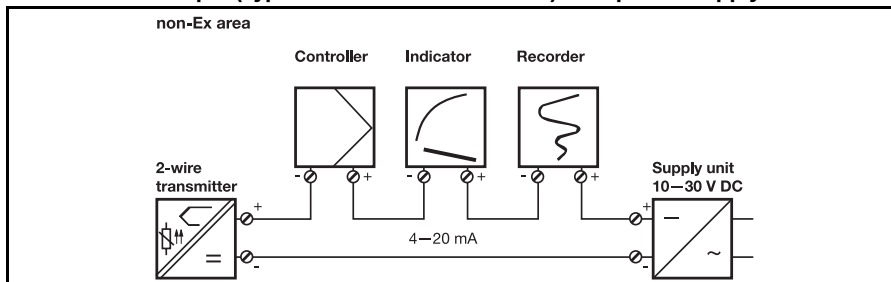

Connection example (Types 707015/... and 707016/...) for Ex application with Ex supply isolator

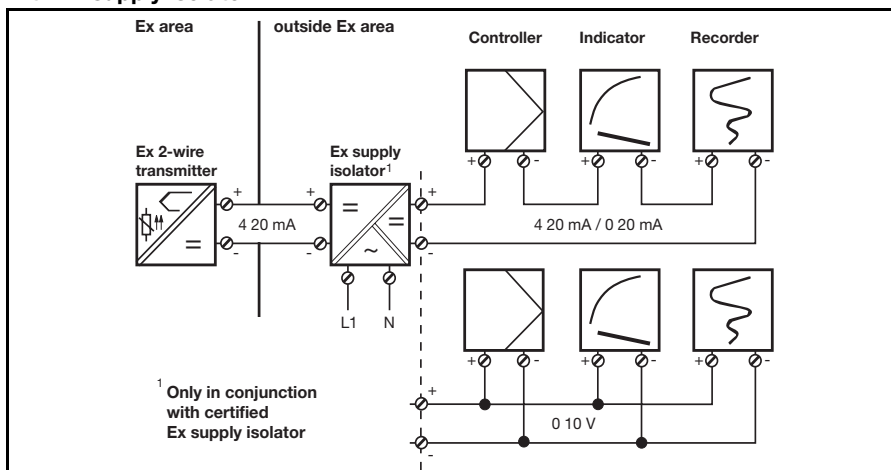

### Features

- Types 707011/..., 707013/... and 707016/... with HART® interface
- Type 707015/... Ex version  
 CE II 1 G EEx ia IIC T6/T5/T4
- Type 707016/... with HART® interface and as Ex version  
 CE II 1 G EEx ia IIC T6/T5/T4  
 II 2 G EEx ia IIC T6/T5/T4
- Types 707012/... and 707013/... in rail-mounting housing
- input and output electrically isolated
- freely configurable ranges
- customized linearization for resistance thermometer and thermocouple
- configuration via Windows setup program



## Technical data

### Input for thermocouple

Designation	Range limits	Accuracy <sup>1</sup> (typical)
Fe-Con L DIN 43 710 <sup>3</sup>	-200 to +900°C	0.5°C
Fe-Con J EN 60 584	-210 to +1200°C	0.5°C above -150°C
Cu-Con U DIN 43 710 <sup>3</sup>	-200 to +600°C	0.5°C
Cu-Con T EN 60 584 <sup>3</sup>	-270 to +400°C	0.5°C above -200°C
NiCr-Ni K EN 60 584	-270 to +1372°C	0.5°C above -140°C
NiCr-Con E EN 60 584 <sup>3</sup>	-270 to +1000°C	0.5°C above -150°C
NiCrSi-NiSi N EN 60 584 <sup>3</sup>	-270 to +1300°C	1°C above -100°C
Pt10Rh-Pt S EN 60 584 <sup>3</sup>	-50 to +1768°C	2°C above 20°C
Pt13Rh-Pt R EN 60 584 <sup>3</sup>	-50 to +1768°C	2°C above 50°C
Pt30Rh-Pt6Rh B EN 60 584 <sup>3</sup>	0 to 1820°C	2°C above 400°C
MoRe5-MoRe41 <sup>2</sup>	0 to 2000°C	2°C above 500°C
W3Re-W25Re D <sup>3</sup>	0 to 2495°C	1°C above 500°C
W5Re-W26Re C <sup>3</sup>	0 to 2320°C	1°C above 500°C
Shortest span	Type L, J, U, T, K, E, N: 50°C Type S, R, B: 500°C Type MoRe5-MoRe41, D, C: 500°C	
Cold junction	Pt100 internal or external cold junction (adjustable from 0 to 80°C)	
Cold junction accuracy	± 1°C	
Sampling rate	> 1 measurement per second	
Sensor current	350nA	
Input filter	1st order digital filter; filter constant adjustable: - on Types 707010/..., 707012/... and 707015/... within the range 0 – 125sec - on Types 707011/..., 707013/... and 707016/... within the range 0 – 100sec	
Features	also programmable in °F; freely programmable range limits; input isolated from output	

<sup>1</sup> The accuracy refers to the maximum range span.

<sup>2</sup> Not available on Types 707011/..., 707013/... and 707016/...

<sup>3</sup> For types 707012/... and 707013/... on request only.

### Input for resistance thermometer

Designation	Range limits	Range	Accuracy <sup>1</sup>
Pt 100 EN 60 751	-200 to +850°C	-100 to +200°C -200 to +850°C	±0.2°C ±0.4°C
Pt 100 JIS	-200 to +649°C	-100 to +200°C -200 to +649°C	±0.2°C ±0.4°C
Pt 500 DIN	-200 to +250°C	-100 to +200°C -200 to +250°C	±0.2°C ±0.4°C
Pt 1000 DIN	-200 to +250°C	-100 to +200°C -200 to +250°C	±0.2°C ±0.4°C
Ni 100	-60 to +250°C	-60 to +250°C	±0.2°C
Ni 500	-60 to +150°C	-60 to +150°C	±0.2°C
Ni 1000	-60 to +150°C	-60 to +150°C	±0.2°C
Connection circuit	2-, 3- or 4-wire circuit		
Shortest span	10°C		
Sensor lead resistance - for 3-, 4-wire connection - for 2-wire connection	≤ 11Ω per conductor measuring resistance + ≤22Ω internal lead resistance		
Sensor current	< 0.6mA		
Sampling rate	> 1 measurement per second		
Input filter	1st order digital filter; filter constant adjustable: - on Types 707010/..., 707012/... and 707015/... within the range 0 – 125sec - on Types 707011/..., 707013/... and 707016/... within the range 0 – 100sec		
Features	also programmable in °F; freely programmable range limits; input isolated from output		

<sup>1</sup> The accuracy refers to the maximum range span.

**Measurement circuit monitoring**

Underrange	linear drop to 3.8mA (as per NAMUR recommendation 43)
Overrange	linear rise to 20.5mA (as per NAMUR recommendation 43)
Probe short circuit / probe and lead break	resistance thermometer: $\leq 3.5\text{mA}$ or $\geq 21.0\text{mA}$ (configurable) thermocouple: $\leq 3.5\text{mA}$ or $\geq 21.0\text{mA}$ (configurable) <sup>1</sup>
Current limiting on probe short circuit or probe break	$\leq 23\text{mA}$

<sup>1</sup> Probe short-circuit recognition is not possible for thermocouple.

**Output**

	Types 707010/..., 707012/..., 707015/...	Types 707011/..., 707013/..., 707016/...
Output signal	proportional DC current 4 – 20 mA, 20 – 4 mA	
Electrical isolation	between input and output	between input and output
Test voltage	$U_{\text{peak}} = 3.75\text{kV}/50\text{Hz}$	$U = 2.0\text{kV}/50\text{Hz}$
Transfer characteristic	linear with temperature	
	customized linearization	
	reversion of output signal	
Burden (Rb)	$Rb = (Ub - 8V) / 0.022A$	$Rb = (Ub - 10V) / 0.022A$
Burden error	$\leq \pm 0.02\% / 100\Omega^1$	
Calibration conditions / accuracy	24V DC at approx. 22°C / $\leq \pm 0.05\%^1$	
1st order digital filter	0 – 125sec configurable	0 – 100sec configurable
Step response 0 – 100 %	< 2sec (with filter constant 0sec)	
Switch-on delay (correct measurement after connecting the supply voltage only after ...)	5sec	4sec

<sup>1</sup> All specified values refer to 20mA full scale.

**Custom linearization<sup>1</sup>**

Number of calibration points	maximum: 40
Interpolation	linear

<sup>1</sup> On Types 707011/..., 707013/... and 707016/... through 4th order polynomial.

**Supply**

Supply voltage (Ub) with reverse polarity protection	Type 707010/...: 8 – 35V DC Type 707012/...: 8 – 35V DC Type 707015/...: 8 – 30V DC	Type 707011/...: 10 – 35V DC Type 707013/...: 10 – 35V DC Type 707016/...: 10 – 30V DC
Supply voltage error	$\leq \pm 0.01\%$ per V deviation from 24V <sup>1</sup>	

<sup>1</sup> All specified values refer to 20mA full scale.

**Environmental influences**

Operating temperature range	-40 to +85°C	
Storage temperature range	-40 to +100°C	
Temperature error	resistance thermometer: $\leq \pm 0.005\%$ per °C deviation from 22°C <sup>1</sup> thermocouple: $\leq \pm 0.005\%$ per °C deviation from 22°C <sup>1</sup> plus accuracy of cold junction	
Long-term stability	$\leq 0.1\text{°C}$ per year <sup>2</sup> or $\leq 0.05\%$ per year <sup>2,3</sup>	
Climatic conditions	rel. humidity $\leq 95\%$ , with condensation	
Vibration strength	according to GL characteristic 2	
EMC	EN 61 326 Class B to industrial requirements	
IP protection	Types 707010/... and 707015/...: IP54 Types 707010/... and 707015/...: IP00 Type 707012/...: IP20	Types 707011/... and 707016/...: IP66 Types 707011/... and 707016/...: IP00 Type 707013/...: IP20

<sup>1</sup> All specified values refer to 20mA full scale

<sup>2</sup> under calibration conditions

<sup>3</sup> % refer to the selected span. The larger value applies.

**Housing**

	<b>Types 707010/..., 707011/..., 707015/..., 707016/...</b>	<b>Types 707012/..., 707013/...</b>
Material	polycarbonate (encapsulated)	polycarbonate
Screw terminal	≤ 1.75mm <sup>2</sup> ; max. tightening torque 0.6Nm	≤ 2.5mm <sup>2</sup> ; max. tightening torque 0.6Nm
Mounting	in terminal head Form B DIN 43 729; in surface-mounting case (on request); in switchgear cabinet (mounting bracket is required)	on DIN rail 35mm x 7.5mm (EN 50 022); on DIN rail 15mm (EN 50 045); on G rail (EN 50 035)
Operating position	unrestricted	
Weight	approx. 40g	approx. 90g



**Version 707015/... (Ex) - Extract from the EC Type-Examination Certificate ZELM 99 ATEX 0018X**

Marking	CE <sub>0032</sub> Ex II 1 G EEx ia IIC T6/T5/T4
Temp. range in "II 2 G" and "II 3 G"	T6 = -40 to +55°C / T5 = -40 to +70°C / T4 = -40 to +85°C
Temp. range in "II 1 G"	T6 = -40 to +40°C / T5 = -40 to +50°C / T4 = -40 to +60°C
Supply circuit Max. values at the terminals 1(+) and 2(-)	U <sub>i</sub> = 30V DC I <sub>i</sub> = 100mA P <sub>i</sub> = 750mW
Internal inductance and capacitance	L <sub>i</sub> = negligible C <sub>i</sub> = negligible
Sensor circuit Max. values at the terminals 3, 4, 5 and 6	U <sub>o</sub> = 9.6V DC I <sub>o</sub> = 4.5mA P <sub>o</sub> = 11mW linear output characteristic
Max. permissible external inductance and capacitance EEx ia IIC EEx ia IIB	L <sub>o</sub> = 4.5mH / C <sub>o</sub> = 709nF L <sub>o</sub> = 8.5mH / C <sub>o</sub> = 1300nF



**Version 707016/... (Ex) - Extract from the EC Type-Examination Certificate PTB 01 ATEX 2124**

Marking	CE <sub>0032</sub> Ex II 1 G EEx ia IIC T6/T5/T4 II 2 G EEx ia IIC T6/T5/T4
Temp. range in "II 2 G" and "II 3 G"	T6 = -40 to +55°C / T5 = -40 to +70°C / T4 = -40 to +85°C
Temp. range in "II 1 G"	T6 = -20 to +40°C / T5 = -20 to +50°C / T4 = -20 to +60°C
Supply circuit Max. value at the terminals 1(+) and 2(-)	U <sub>i</sub> = 30VDC I <sub>i</sub> = 100mA P <sub>i</sub> = 750mW
Internal inductance and capacitance	L <sub>i</sub> = negligible C <sub>i</sub> = negligible
Sensor circuit Max. values at the terminals 3, 4, 5 and 6	U <sub>o</sub> = 5V DC I <sub>o</sub> = 5.4mA P <sub>o</sub> = 6.6mW linear characteristic
Internal inductance and capacitance	L <sub>i</sub> = negligible C <sub>i</sub> = negligible
Connected circuit <b>without</b> lumped external inductance or capacitance	L <sub>o</sub> = 1000mH C <sub>o</sub> = 100µF
Connected circuit <b>with</b> lumped external inductance or capacitance	
EEx ia IIC EEx ia IIB, EEx ia IIA	L <sub>o</sub> = 100mH / C <sub>o</sub> = 2µF L <sub>o</sub> = 100mH / C <sub>o</sub> = 9.9µF

### Connection diagram

	Connection for		Terminals	
		Supply voltage for Type 707010/... 8 – 35V DC  Supply voltage for Type 707011/... 10 – 35V DC  Supply voltage for Type 707015/... 8 – 30V DC (Ex) <sup>1</sup>  Supply voltage for Type 707016/... 10 – 30V DC (Ex) <sup>1</sup>  Current output 4 – 20mA	+1 $R_B = \frac{U_b - 8V}{22mA}$  -2 $R_B = \frac{U_b - 10V}{22mA}$  $R_B = \frac{U_b - 8V}{22mA}$  $R_B = \frac{U_b - 10V}{22mA}$  R <sub>B</sub> = burden resistance U <sub>b</sub> = supply voltage	
Ex version only in conjunction with certified Ex transmitter supply unit				
	Analog inputs			
	Thermocouple	+4 -6		
	Resistance thermometer in 2-wire circuit	3 6	$R_L \leq 11\Omega$ R <sub>L</sub> = lead resistance per conductor	
	Resistance thermometer in 3-wire circuit	3 5 6	$R_L \leq 11\Omega$ R <sub>L</sub> = lead resistance per conductor	
	Resistance thermometer in 4-wire circuit	3 4 5 6	$R_L \leq 11\Omega$ R <sub>L</sub> = lead resistance per conductor	
Ex version: please note connection data of the Ex input circuit!				

<sup>1</sup> On Types 707015/... and 707016/... only up to 30V. The connection must only be made to an intrinsically safe circuit.

<p>Depth behind panel 98 max.</p>	Connection for		Terminals	
		Supply voltage for Type 707012/... 8 – 35V DC  Supply voltage for Type 707013/... 10 – 35V DC  Current output 4 – 20mA	+81 $R_B = \frac{U_b - 8V}{22mA}$  -82 $R_B = \frac{U_b - 10V}{22mA}$  R <sub>B</sub> = burden resistance U <sub>b</sub> = supply voltage	
	Analog inputs			
	Thermocouple (special feature: see order details)	+11 -12		
	Resistance thermometer in 2-wire circuit	11 13	$R_L \leq 11\Omega$ R <sub>L</sub> = lead resistance per conductor	
	Resistance thermometer in 3-wire circuit	11 12 13	$R_L \leq 11\Omega$ R <sub>L</sub> = lead resistance per conductor	
Resistance thermometer in 4-wire circuit	11 12 13 14	$R_L \leq 11\Omega$ R <sub>L</sub> = lead resistance per conductor		

Caution: the order details on P. 8 must be observed

## Setup program

The setup program is available for configuring the transmitter from a PC. With Types 707010/..., 707012/... and 707015/..., the connection is via the PC interface with a TTL/RS232 converter (or an USB/RS232 converter) and the setup interface of the transmitter, in the case of Types 707011/..., 707013/... and 707016/..., via a HART® modem. The connection for the setup circuit must only be used outside the hazardous area. It is not permissible to configure the transmitter inside the Ex area. The protective cover must be closed after programming (Types 707010/... and 707015/...).

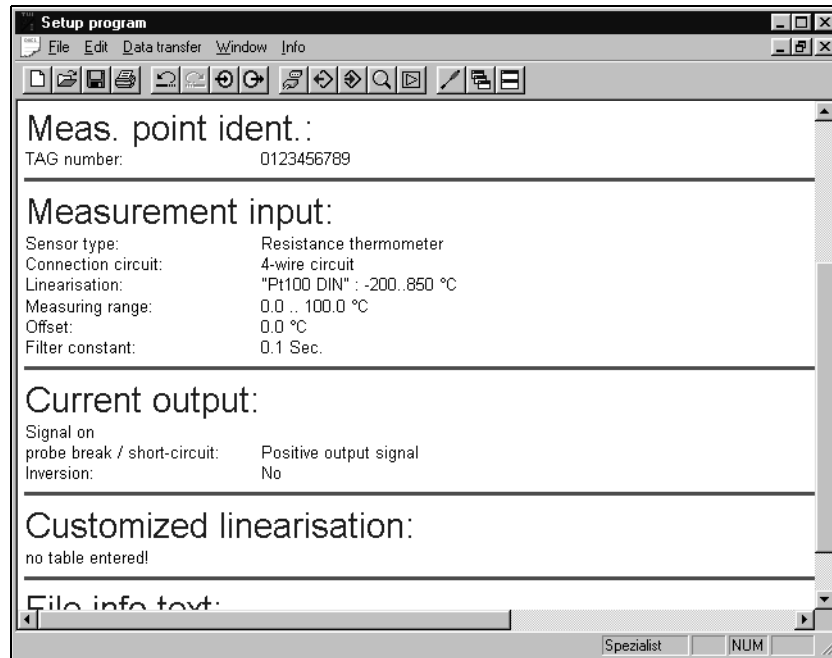

### Configurable parameters

TAG number (10 characters) on Types 707011/..., 707013/... and 707016/..., 8 characters only, but with additional 16-character description	Sensor type
Connection circuit (2-/3-/4-wire)	External and internal cold junction
Customized linearization	Range limits
Output signal rising/falling (reversion)	Digital filter
Response to probe break/short circuit	Recalibration/fine calibration (not on Types 707011/..., 707013/... and 707016/...)
Lead resistance with 2-wire circuit	

If no power supply (supply isolator) is available, the 2-wire transmitter Type 707010/..., 707012/... or 707015/... has to be configured using a 9V block battery as a power source.

### Fine calibration (not on Types 707011/..., 707013/... and 707016/...)

Fine calibration means correction of the output signal. The signal can be adjusted within  $\pm 5\%$  of the 20 mA full-scale value. Fine calibration is performed through the setup program. Values for 4 mA (zero), 20 mA (full scale) and offset can be calibrated separately, via the setup program.

### Hardware and software requirements

The following hardware and software requirements must be met when installing and operating the setup program:

IBM-PC or compatible PC from 486DX-2-100	16 MB main memory
15MB free space on hard disk	CD-ROM drive
1 free serial interface	Windows 95 or above, Windows NT4.0 or Windows 2000

## Setup interface (Types 707010/... and 707015/...)

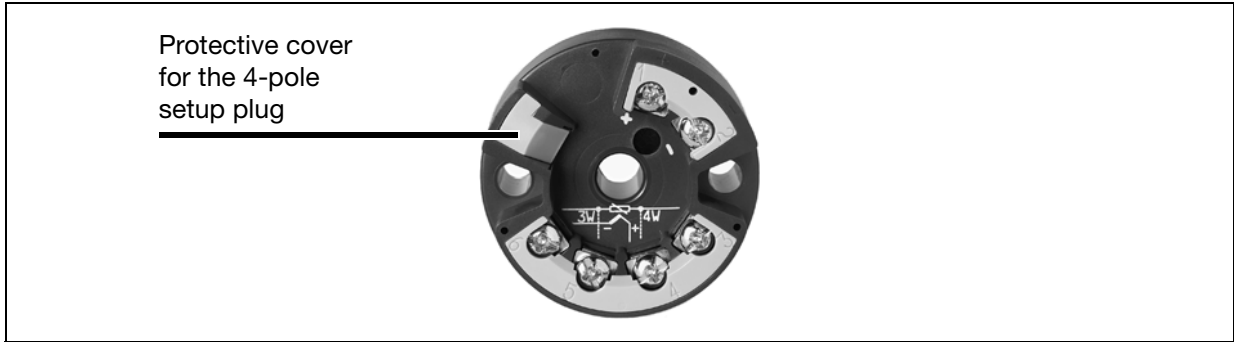

## HART® interface (Types 707011/... and 707013/...)

### Connection via HART® communicator and HART® modem

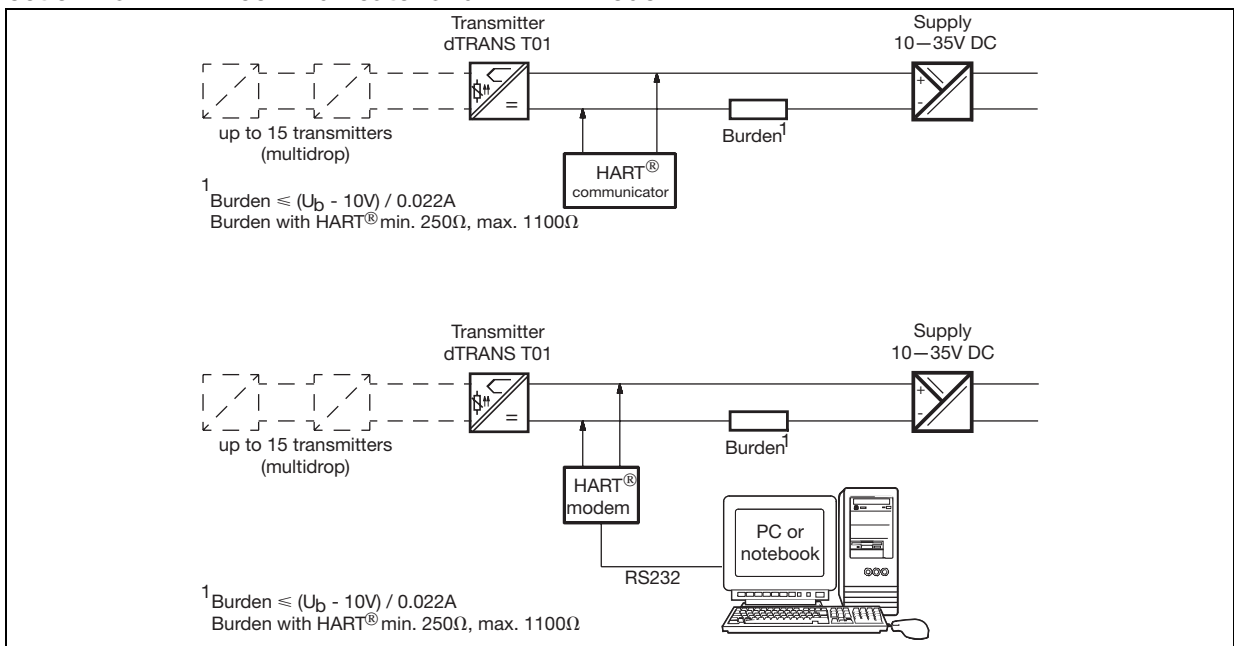

## HART® interface (Type 707016/...)

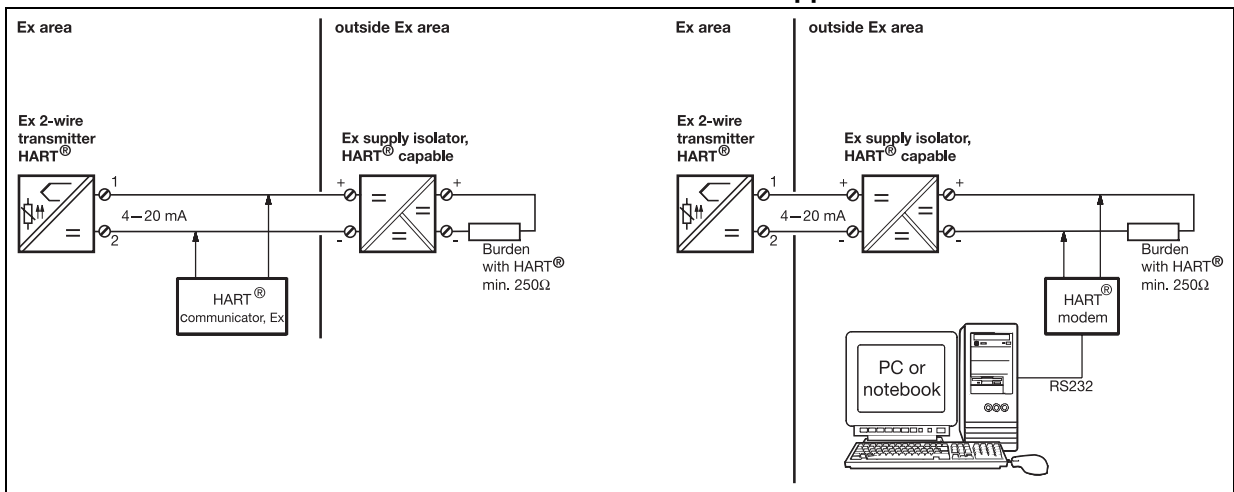

### Connection via HART® communicator and HART® modem for Ex application



## Order details: JUMO dTRANS T01 / T01T

### Programmable 2-wire transmitter

#### (1) Basic version

	707010	programmable 2-wire transmitter	
	707011	programmable 2-wire transmitter with HART® interface	
	707012	programmable 2-wire transmitter installed in rail-mounting housing <sup>1</sup> (Caution: observe the footnotes)	
	707013	programmable 2-wire transmitter with HART® interface installed in rail-mounting housing <sup>1</sup> (Caution: observe the footnotes)	
	707015	programmable 2-wire transmitter with Ex protection EEx ia IIC T6	
	707016	programmable 2-wire transmitter with HART® interface and Ex protection	
	<b>(2) Input (programmable)</b>		
x x x x x x	888	factory-set (Pt100 DIN 4w / 0 – 100°C)	
x x x x x x	999	configuration to customer specification <sup>2</sup>	
	<b>(3) Output (proportional DC current)</b>		
x x x x x x	888	factory-set (4 – 20mA)	
x x x x x x	999	configuration to customer specification (20 – 4mA)	
	<b>(4) Probe break/ short circuit</b>		
x x x x x x	888	factory-set (positive protection)	
x x x x x x	999	configuration to customer specification (negative protection)	

Order code

(1) / (2) - (3) - (4)

Order example

707010 / 888 - 888 - 888

<sup>1</sup> When ordering, please specify the type of sensor required (thermocouple or resistance thermometer). For thermocouple inputs, the sensor input cannot be changed retrospectively, because of the internal compensating cable. For resistance thermometer inputs, all types of resistance thermometers listed on P. 2 can be connected, but no thermocouples. Thermocouple inputs are available on request.

<sup>2</sup> Probe type and range have to be specified in plain text for configuration to customer specification.

## Standard accessories

- 1 Operating Instructions
- Fixing items: 2 screws, 2 compression springs (not for Types 707012/... and 707013/...)

## Accessories

- PC setup program, multilingual
- PC interface cable with TTL/RS232 converter and adapter (socket) for Types 707010/..., 707012/... and 707015/...
- PC interface cable with USB/RS232 converter and adapter (socket) for Types 707010/..., 707012/... and 707015/...
- HART® modem (for Types 707011/..., 707013/... and 707016/...), Sales No. 40/00345666
- HART® communicator (for Types 707011/..., 707013/... and 707016/...) Sales No. 40/00345668 (German) and 40/00384998 (English)
- Power supply units 1- and 4-way (Data Sheet 70.7500)
- Isolating amplifier and supply isolator (Data Sheet 70.7510)
- Ex transmitter supply unit (Data Sheet 70.7520)
- Ex supply unit with isolating transformer, HART® capable for Type 707016/... (Data Sheet 40.4757)
- Bracket for mounting on DIN rail, Sales No. 70/00352463