

**M. K. Juchheim
GmbH & Co**
36035 Fulda, Germany
Phone (0661) 6003 - 0
Fax (0661) 6003 - 607
Telex 49 701 juf d
email JUMO_de@e-mail.com

**UK
Jumo Instrument Co. Ltd.**
Temple Bank, Riverway
Harlow, Essex CM20 2TT
Phone (01279) 63 55 33
Fax (01279) 63 52 62

**USA
Jumo Process Control Inc.**
735 Fox Chase
Coatesville, PA 19320
Phone 610 - 380 - 8002
800 - 554 JUMO
Fax 610 - 380 - 8009



Controller module

Brief description

The unit is a module of the JUMO mTRON control and automation system. The plastic housing measures 91 mm x 85.5 mm x 73.5 mm (W x H x D) and is mounted on a standard rail.

Using the function blocks ramp, maths, controller and limit comparator, it is possible to build up a great variety of automation structures. Each of the analogue inputs is monitored against adjustable limit values. In addition to four definable setpoints the memory stores two controller parameter sets. A fully developed auto-tuning function automatically adapts the controller to the characteristics of the process.

In addition to two logic inputs there are 2 analogue inputs for standard signals, Pt100 and thermocouples. There are 2 switching outputs and one analogue output. The analogue inputs and the analogue output can be configured without hardware changes. The controller module incorporates a network connection for data interchange.

A screened twisted pair is used as transmission line. There is a setup interface for module parameter setting and configuration from a PC under the JUMO mTRON-iTOOL project design software. The electrical connections are made through plug-in connectors with screw terminals.



Type 704010/0-...

Block structure

2 analogue inputs

for Pt 100, thermocouples, standard signals, potentiometer, resistance or AC current.
Functions:
- control variable
- external setpoint
- input variable for maths functions
- input variable for the limit comparator
- output of measurements to the network
- stroke retransmission
- heater current monitoring

2 logic inputs

for floating contacts, TTL or CMOS level
Functions:
- setpoint changeover
- ramp reset
- ramp stop
- ramp inactive
- changeover to manual operation
- start of self-optimisation
- parameter set switching

Input

network variables

Analogue network variables
Logic network variables



Setup interface

for configuration and parameter setting

JUMO mTRON-iTOOL

Functions:
- linking to other JUMO mTRON modules
- configuration and parameter setting
- project archiving
- online process diagnostics

3 outputs

2 switching outputs (e. g. relays) and 1 analogue output
Functions:
- controller output 1
- controller output 2
- limit comparator output
- operation via a network variable
- measurement 1 + 2
- maths function

Output

network variables

Analogue network variables
Logic network variables



1. LON[®] = Local Operating Network
Registered trademark of the
ECHELON Corporation

Features

- **Maths functions**
Difference, humidity, ratio, square root, square, minimum, maximum, absolute value, sum, product, mean value
- **Ramp function**
Setpoint ramp for a time-defined approach of the process to the setpoint
- **Limit comparator**
Comparator and window functions, direct or reversed
- **Switching setpoint/parameter set**
Facility for switching between 4 setpoints and 2 controller parameter sets through logic inputs and network variables.
- **Range monitor**
The analogue inputs are monitored against defined limit values
- **Cascade output**
Conversion of the setpoint input for an external slave controller
- **Setup interface**
For configuration and setting of parameters, the module is linked to a PC via a PC interface
- **Plug & Play function**
Problem-free replacement of modules without re-configuration

Technical data

Hardware inputs

Analogue inputs

Measurement input

- resistance thermometer
- thermocouples
- standard signals (current/voltage)
- AC current (50/60Hz sinusoidal)
- resistance
- potentiometer

Sampling time

420msec for all inputs

Functions

- control variable
- limit comparator
- maths function
- network output
- external setpoint
- heater current monitoring
- stroke retransmission
- analogue output

Sensor	Measurement range ¹	Internal resistance/voltage drop	Measurement circuit monitoring		Resolution	Measurement accuracy	
			Recognition of sensor break	Recognition of sensor short-circuit		Maximum measurement error ¹ at 23°C	Ambient temperature drift per 10°C
Pt 100	-200 to +850°C (-200 to +850°C)		X	X	0.025°C	± 0.4°C	± 0.21°C
Fe-Con L	-200 to +900°C (-200 to +900°C)	47MΩ	X	-	0.05°C	± 1.8°C	± 0.9°C
Fe-Con J	-200 to +1200°C (-100 to +1200°C)	47MΩ	X	-	0.05°C	± 1.8°C	± 1.2°C
NiCr-Ni K	-200 to +1372°C (-100 to +1372°C)	47MΩ	X	-	0.07°C	± 1.9°C	± 1.4°C
Cu-Con U	-200 to +600°C (-100 to +600°C)	47MΩ	X	-	0.07°C	± 1.7°C	± 0.6°C
Cu-Con T	-200 to +400°C (-200 to +400°C)	47MΩ	X	-	0.07°C	± 1.6°C	± 0.4°C
NiCrSi-NiSi N	-100 to +1300°C (-100 to +1300°C)	47MΩ	X	-	0.07°C	± 2.3°C	± 1.3°C
Pt10Rh-Pt S	0 – 1768°C (100 – 1768°C)	47MΩ	X	-	0.3°C	± 3.4°C	± 1.7°C
Pt13Rh-Pt R	0 – 1768°C (100 – 1768°C)	47MΩ	X	-	0.25°C	± 3.4°C	± 1.7°C
Pt30Rh-Pt6Rh B	0 – 1820°C (400 – 1820°C)	47MΩ	X	-	0.3°C	± 4.4°C	± 1.4°C
Standard signals	-50 to +50mV	47MΩ	X	-	2.5µV	± 0.04mV	± 0.05mV
Standard signals	0 – 50mV	47MΩ	X	-	2.5µV	± 0.04mV	± 0.05mV
Standard signals	10 – 50mV	47MΩ	X	X	2.5µV	± 0.04mV	± 0.05mV
Standard signals	-10 to +10V	2MΩ	-	-	500µV	± 8mV	± 15mV
Standard signals	0 – 10V	2MΩ	-	-	500µV	± 8mV	± 15mV
Standard signals	2 – 10V	2MΩ	X	X	500µV	± 8mV	± 15mV
Standard signals	-1 to +1V	2MΩ	-	-	50µV	± 0.8mV	± 1.5mV
Standard signals	0 – 1V	2MΩ	-	-	50µV	± 0.8mV	± 1.5mV
Standard signals	0.2 – 1V	2MΩ	X	X	50µV	± 0.8 mV	± 1.5mV
Standard signals	0 – 20mA	less than 1V	-	-	1µA	± 15µA	± 30µA
Standard signals	4 – 20mA	less than 1V	X	X	1µA	± 15µA	± 30µA
AC current	0 – 50mA	less than 1V	-	-	5µA	1mA	± 100µA
Resistance	0 – 400Ω		X	X	0.01Ω	± 0.15Ω	± 0.1Ω
Potentiometer	0.1 – 10KΩ		X (slider)	-	0.01 %	0.25 %	0.1 %

X: recognized -: not recognized

1. The accuracy given refers to the ranges given in brackets. With thermocouples, the accuracy is obtained only in the specified operating position and after an operating time of at least 1 hour.

Displays and controls

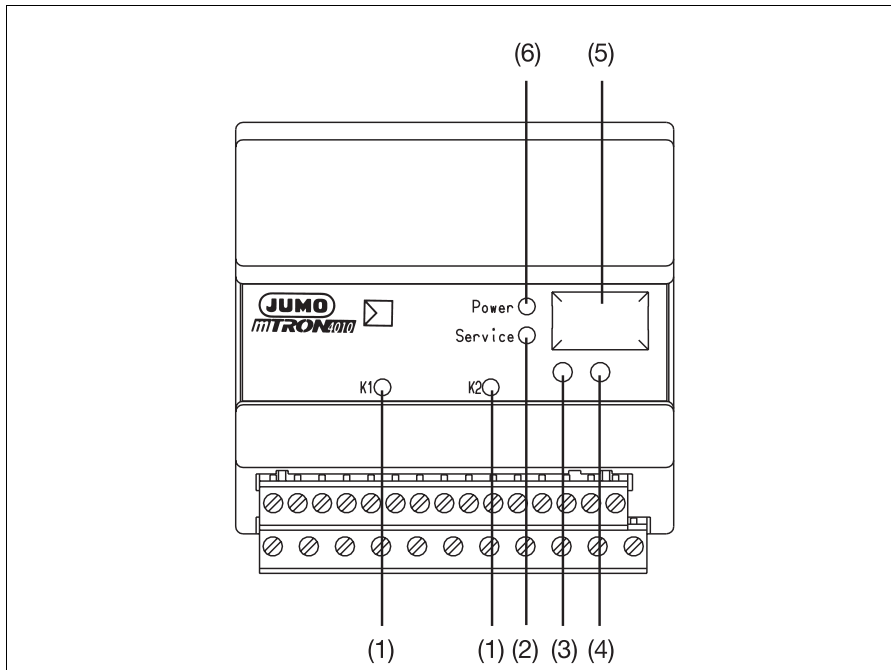

(1)	Status LED, yellow for the logic outputs K1 and K2; lights up when relay is energised or logic output is activated	(4)	Installation key the module reports to the JUMO mTRON-iTOOL project design software or the operating unit
(2)	Service LED, red - lights up on operating fault - flashes when the mechanical con- nection to the module from JUMO mTRON-iTOOL or the operat- ing unit is being checked by a test signal ("wink"). - long flashing pulses (3 sec on, 1 sec off) when a Plug & Play fault occurs	(5)	Setup interface for the PC interface line which links the module to the PC
(3)	Switch for the termination resistance of the LON network	(6)	Power LED, green lights up when the supply is switched on

Logic inputs

activation: floating contacts,
TTL or CMOS level

Functions:

- setpoint selection
- ramp reset
- ramp stop
- ramp inactive
- changeover to manual operation
- start autotuning
- parameter set switching

Hardware outputs

Analogue output

Signal	Burden
0 – 10V	500Ω min.
2 – 10V	500Ω min.
0 – 20mA	500Ω max.
4 – 20mA	500Ω max.

Accuracy: 0.25 %
Resolution: 16 bit

Functions:

- controller output 1 or 2
- output of a maths function
- output of a network variable
- output of a measurement value of
the analogue inputs

Switching outputs

Functions:

- controller output 1 or 2
- limit comparator output
- output of a network variable

Relay outputs

Type: changeover contact

Nominal voltage: 250V

Nominal current: 3A

Contact rating: 3A, 250V AC
resistive load

Life: 5·10⁵ operations
on resistive load

Contact material: AgCdO (hard gold plated)

Contact protection circuit:

Varistor (make contact only)

Minimum load: 10mA 5V DC

Solid-state relay output

Type: 1A 250V AC

Overvoltage protection: varistor

Logic output

Type: 0/12V

internal resistance: 600Ω

Input

network variables

Analogue network variables

Functions:

- external setpoint
- maths function
- ramp start
- external control variable
- stroke retransmission
- manual control output
- additive disturbance
- multiplying disturbance
- analogue output

Logic network variables

Functions:

- setpoint selection
- ramp reset
- ramp stop
- ramp inactive
- changeover to manual operation
- start of self-optimisation
- parameter set switching
- direct operation of the relays

Output

network variables

Analogue network variables

Output cycle:

420msec – 8.4sec, adjustable

Functions:

- measurement analogue input 1
- measurement analogue input 2
- process variable
- setpoint
- setpoint output for slave controller
(cascade control)
- controller analogue output 1
- controller analogue output 2

Logic network variables

Output cycle: controlled by event,
but at least every 6sec

Functions:

- limit comparator output
- monitoring the analogue inputs
- monitoring function for the
network inputs (combined alarm)

Controller structures

Controller type	Controller structure
1-setpoint controller	P, I, PI, PD, PID
2-setpoint controller	P, I, PI, PD, PID
Proportional controller.	P, I, PI, PD, PID
Modulating controller	PI, PID
Proportional control- ler with integral actuator driver	P, I, PI, PD, PID

General data

Environmental conditions to EN 61 010

Operating and ambient temperature:

0 – 55 °C

Permitted storage temperature:

–40 to +70 °C

Relative humidity: rH 80 % max.

Pollution degree 2

Overvoltage category 2

Housing

Material: plastic,
self-extinguishing

Flammability Class: UL 94 VO

Protection: IP20 (to EN 60 529)

Mounting: on standard rail

Supply

110 – 240 V AC, +10/–15%, 48 – 63 Hz,

or 20 – 53 V AC/DC, 48 – 63 Hz

Power consumption: 5 VA max.

Network (LON interface)

Transceiver: free topology FTT-10A

Topology: ring, star, line or
mixed structure

Baud rate: 78 kbaud

Max. lead length (depending on lead type):

line: 2700m

star: 500m

ring: 500m

mixed: 500m

Max. number of modules: 64

Operation and project design

Operation, parameter setting and configuration of JUMO mTRON modules can be carried out from the JUMO mTRON operating unit.

The JUMO mTRON-iTOOL project design software permits convenient design and start-up of a JUMO mTRON system.

The projects can be archived and documented. Individual modules are linked via LON by assigning network variable (NV) names.

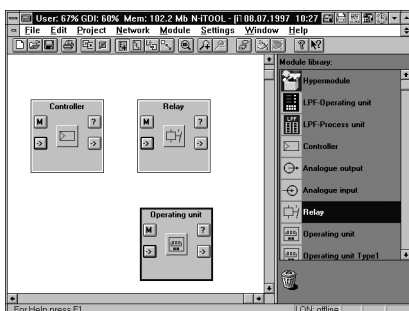

Connection diagram

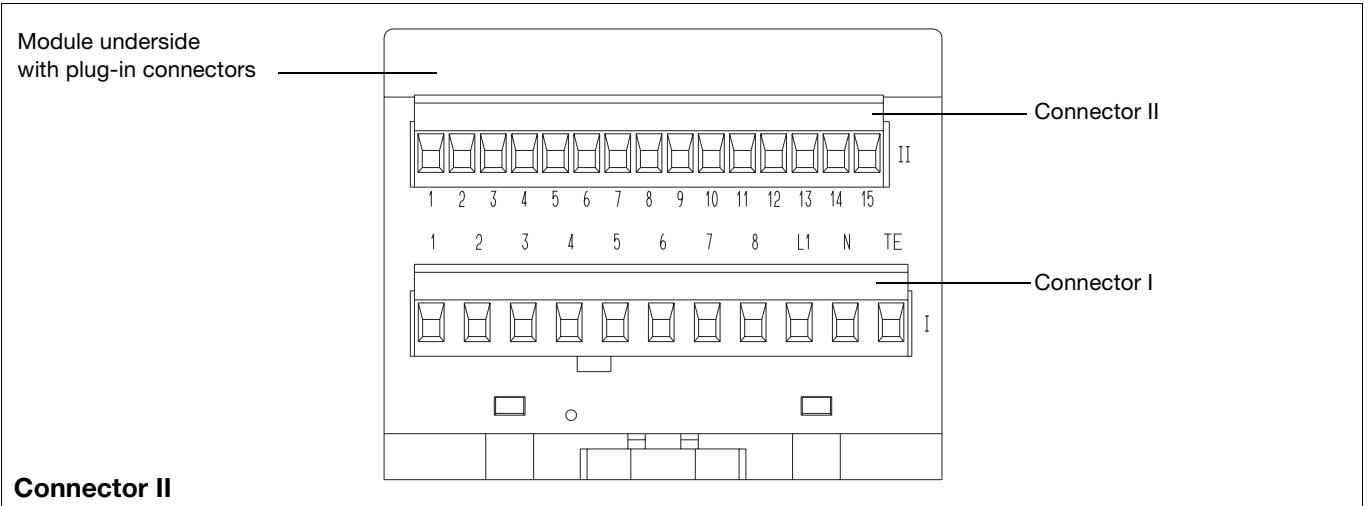

Connection for	Terminals		Notes	Diagram
Analogue inputs	Input 1	Input 2		
Thermocouple	II_8+ II_7-	II_12+ II_11-		
Resistance thermometer in 3-wire circuit	II_8 II_6 II_7	II_12 II_10 II_11		
Resistance thermometer in 2-wire circuit	II_6 II_8 II_7	II_10 II_12 II_11	$R_A = R_{lead}$	
Potentiometer	II_6 II_8 II_7	II_10 II_12 II_11	E=end S=slider A=start	
Voltage input -50 to +50mV	II_8+ II_7-	II_12+ II_11-		
Voltage input -1 to + 1V -10 to +10V	II_5+ II_7-	II_9+ II_11-		
Current input 0 — 20mA	II_8+ II_7-	II_12+ II_11-		
AC current input 0 — 50mA	II_8 II_7	II_12 II_11		
Logic inputs floating contact	II_1 II_2	II_1 II_3		
LON interface	II_13 = TE		screen	
	II_14 = Net_A II_15 = Net_B		any polarity	
Technical earth	II_4			

Connector I

Connection for	Terminals			Notes	Diagram
	Output 1	Output 2	Output 3		
Relay output 3A 250VAC, resistive load	I_3 I_4 I_5	I_6 I_7 I_8		O=n.c.(break) P=common S=n.o. (make)	
Logic output 12V 20mA	I_5+ I_4-	I_8+ I_7-			
Solid-state relay output 250V 1A	I_4 I_5	I_7 I_8			
Analogue output 0 – 10V/ 2 – 10V 0 – 20mA/ 4 – 20mA			I_1 – I_2 +		
Supply as label	AC	DC			
	I_L1 line I_N neutral I_TE technical earth	I_L1 } any I_N } polarity I_TE technical earth			

Dimensions

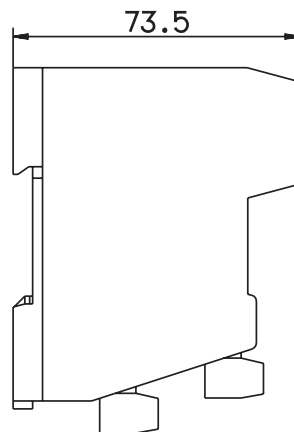
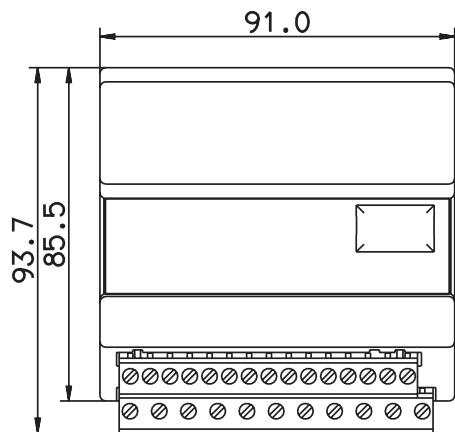

mm	inch
73.5	2.89
85.5	3.37
91.0	3.58
93.7	3.69

Isolation

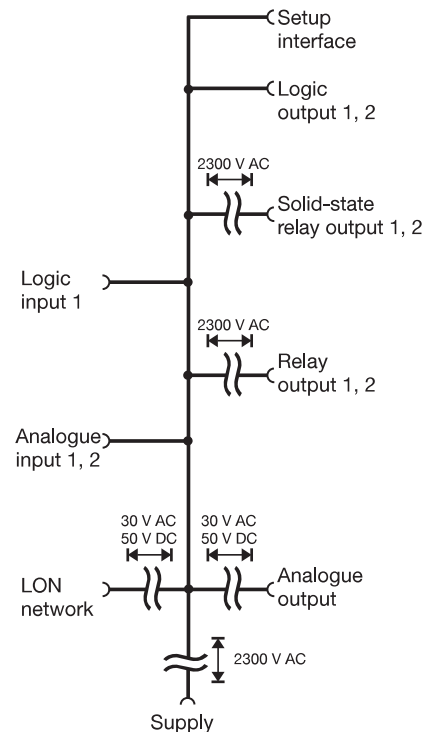

Ordering details

704010/0- (1) (2) (3)
 ... - ... - ..

(1) Inputs

Standard version 888

Measurement input	Inputs	
	1	2
Pt 100 resistance thermometer	X	X
Thermocouples Fe-Con L Fe-Con J NiCr-Ni K Cu-Con U Cu-Con T NiCrSi-NiSi N Pt10Rh-Pt S Pt13Rh-Pt R Pt30Rh-Pt6Rh B		
Standard signals 0 – 50 mV 10 – 50 mV -50 to +50 mV 0 – 1 V 0.2 – 1 V -1 to +1 V 0 – 10 V 2 – 10 V -10 to +10 V 0 – 20 mA 4 – 20 mA -20 to +20 mA		
AC current 0 – 50mA		
Resistance 0 – 400Ω		
Potentiometer 0.1 – 10KΩ		

Special version 999

Factory configured to customer specification.
Please specify inputs in plain language.

(2) Outputs

Outputs	Code
2 relays (changeover) and 1 analogue output ¹ (selectable)	302
2 logic outputs 12V 20mA and 1 analogue output ¹ (selectable)	304
2 solid-state relay outputs 250V 1A and 1 analogue output ¹	305

1. analogue outputs:

0 – 10V	
2 – 10V	
0 – 20mA	X
4 – 20mA	

Special version 999

Factory configured to customer specification.
Please specify outputs in plain language.

X = factory-set, freely programmable

(3) Supply

Type	Code
110 – 240V AC +10/-15%, 48 – 63Hz	23
20 – 53V AC/DC, 48 – 63Hz	22

Standard accessory

1 Installation Instructions M 70.4010

Accessories

PC interface

with TTL/RS232C converter

for connecting the module to a PC;
length 2m.

Sales No. 70/00301315

Project design software

JUMO mTRON-iTOOL

Using the JUMO mTRON- iTOOL project design software the modules can be designed graphically on the PC. The user is able to link modules of the JUMO mTRON family and to configure the application-specific parameters.

System Manual JUMO mTRON

Documentation of configuration, parameter setting and installation of the modules.

Sales No. 70/00334336

JUMO mTRON modules

Controller module

Data Sheet 70.4010

Relay module

Data Sheet 70.4015

Analogue input module

Data Sheet 70.4020

Analogue output module

Data Sheet 70.4025

Logic module

Data Sheet 70.4030

Operating unit

Data Sheet 70.4035

Communication module

Data Sheet 70.4040

Project design software

JUMO mTRON-iTOOL

Data Sheet 70.4090