

# PACSystems™ RX7i

## IC698CPE010/CPE020

### Central Processing Unit

GFK-2226C  
August 2004

The RX7i CPUs are programmed and configured by the programming software to perform real time control of machines, processes, and material handling systems. The CPU communicates with I/O and smart option modules over a rack-mounted backplane using the VME64 Standard format. It communicates with the programmer and HMI devices via the embedded Ethernet ports or a serial port using SNP Slave protocol.

- CPE010:** 300MHz Celeron microprocessor
- CPE020:** 700MHz Pentium III microprocessor

## Features

**Note:** For additional features, refer to the Important Product Information document provided with each CPU.

- Contains 10 Mbytes of battery-backed user memory and 10 Mbytes of non-volatile flash user memory.
- Provides access to bulk memory via reference table %W. The upper limit of this memory area can be configured to the maximum available user RAM.
- Configurable data and program memory.
- Programming in Ladder Diagram and C.
- Supports auto-located Symbolic Variables that can use any amount of user memory.
- Reference table sizes include 32Kbits for discrete %I and %Q and up to 32Kwords each for analog %AI and %AQ.
- Supports Series 90-70 discrete and analog I/O, communications, and other modules. For a list of modules supported, refer to the PACSystems RX7i Installation Manual, GFK-2223.
- Supports all non-GE Fanuc VME modules supported by Series 90-70.
- Supports PLC data monitoring over the web. Allows a combined total of up to 16 web server and FTP connections.
- Supports up to 512 program blocks. Maximum size for a block is 128KB.
- Test Edit mode allows you to easily test modifications to a running program.
- Bit-in-word referencing allows you to specify individual bits in a WORD reference in retentive memory as inputs and outputs of Boolean expressions, function blocks, and calls that accept bit parameters.
- Battery-backed calendar clock.
- In-system upgradeable firmware.
- Three isolated serial ports: an RS-485 serial port, an RS-232 serial port, and an RS-232 Ethernet station manager serial port.
- The embedded Ethernet interface provides:
  - Data exchange using Ethernet Global Data (EGD)
  - TCP/IP communication services using SRTTP
  - Full PLC programming and configuration services
  - Comprehensive station management and diagnostic tools
  - Two full-duplex 10BaseT/100BaseT/TX (RJ-45 Connector) ports with an internal network switch providing auto-negotiated network speed, duplex mode, and crossover detection.

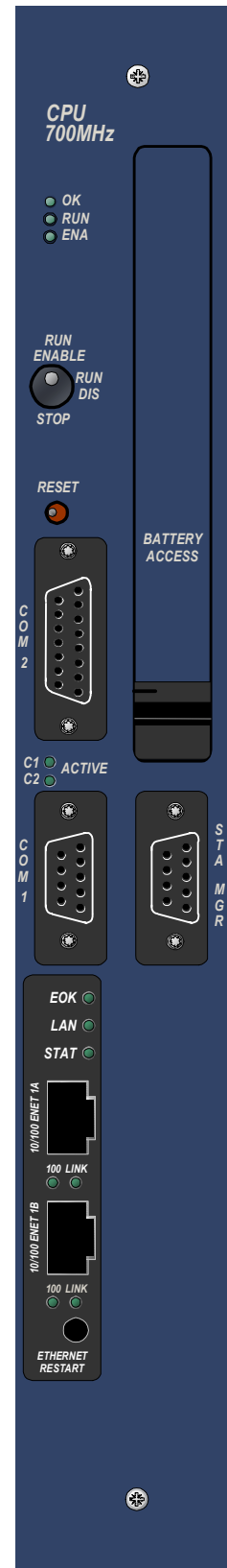

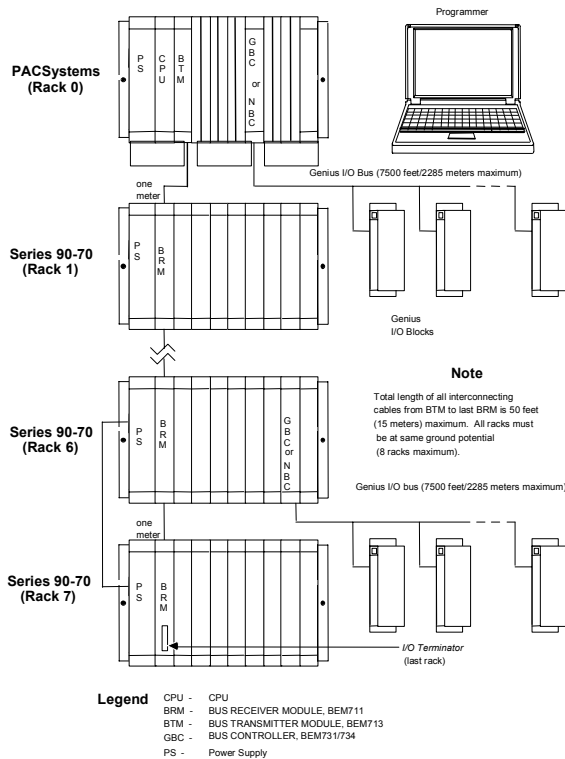

Figure 1. Control System Configuration Example

## User RAM Memory

The RX7i CPUs have 10 Mbytes of battery-backed CMOS RAM memory for user data (program, configuration, register data, and symbolic variable) storage.

## User Flash Memory

The RX7i CPUs have 10 Mbytes of built-in flash memory for user data (program, configuration, register data, and symbolic variable) storage. Use of this flash memory is optional.

## Firmware Storage in Flash Memory

This CPU uses non-volatile flash memory for storing the operating system firmware. This allows firmware to be updated without disassembling the module or replacing EPROMs. The operating system firmware is updated by connecting a PC compatible computer to the module's RS-232 serial port and running the software included with the firmware upgrade kit.

## Operation, Protection, and Module Status

Operation of this module can be controlled by the three-position RUN/STOP switch or remotely by an attached programmer and programming software. Program and configuration data can be locked through software passwords. The status of the CPU is indicated by the three CPU LEDs on the front of the module. (For details, see "Indicators.") Two LEDs indicate activity on the serial ports. Seven additional LEDs indicate the status of the Ethernet interface. The RUN/STOP switch can be disabled.

## Battery

A three-cell lithium battery pack (IC698ACC701) is installed as shown in the figure below. The battery maintains program and data memory when power is removed and operates the calendar clock. When replacing the battery, be sure to install a new battery before disconnecting the old one.

**Disposal of lithium batteries must be done in accordance with federal, state, and local regulations.** Be sure to consult with the appropriate regulatory agencies before disposing of batteries. For details, refer to the Material Safety Data Sheet provided with the battery.

Specific indication of a low or failed battery is described in the *PACSystems CPU Reference Manual*, GFK-2222.

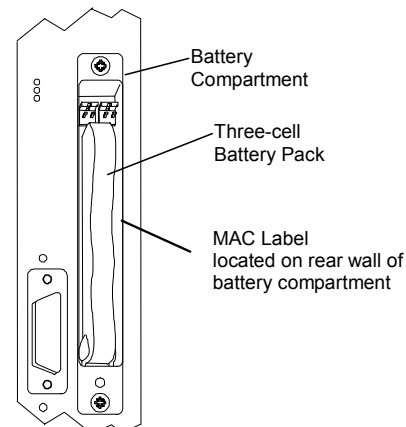

Figure 2. Battery Compartment

## Installation

It is the responsibility of the OEM, system integrator, or end user to properly install the control system equipment for safe and reliable operation. Product manuals provide detailed information about installation, startup, and proper use of the control system equipment.

Installation should not be attempted without referring to the *PACSystems RX7i Installation Manual*, GFK-2223.

1. Read and record the 12-digit hexadecimal MAC Address from the printed label located inside the battery compartment.
2. Make sure that rack power is off.
3. Install the CPU module in slot 1 of rack 0 (see Figure 1). Ensure mounting screws are tightened to completely secure the CPU in the rack.
4. Connect one or both Ethernet ports to the Ethernet network.
5. Turn on power. The module should power up. When the CPU has successfully completed initialization, the OK LED stays on and the RUN and EN LEDs are off; the EOK LED stays on. The CPU is now ready to be programmed.
6. Connect the battery to either of the battery connectors on the module. (You can connect the battery at any step in the installation process but it will begin to drain immediately unless power is applied. To maximize battery life, install it after power has been turned on).

After the program has been verified, the toggle switch can be moved to the appropriate operation mode position: RUN EN (run with outputs enabled), RUN DIS (run with outputs disabled), or STOP. The LEDs indicate the position of the toggle switch, status of serial port activity, status of Ethernet interface including Ethernet OK, LAN, STATus, activity, and 10 or 100Mbps rate used. For details, see “LEDs” on page 6.

## Programmer Connection

The programmer can communicate with the CPU via the embedded or rack-based Ethernet interface, or via serial port 1 or serial port 2.

The programmer uses SNP for serial communications with the CPU. For information on connecting to a serial port, see “Serial Cable Lengths and Shielding” on page 4.

Connecting your programmer via an Ethernet TCP/IP network requires a CAT5 standard Ethernet cable with RJ-45 connectors. Before connecting the programmer and RX7i to the Ethernet TCP/IP network you must set the IP address in

the CPU, using the Initial IP Address software tool. After setting the IP address, connect the RX7i and the computer running the programming software to the Ethernet Interface. For detailed information on programmer connection via Ethernet TCP/IP, refer to the *TCP/IP Ethernet Communications for PACSystems RX7i User’s Manual*, GFK-2224.

For a description of programming functions, consult *Proficy™ Machine Edition Logic Developer-PLC Getting Started*, GFK-1918 and the programming software online help.

## Serial Ports

The CPU has three independent, on-board serial ports, accessed by connectors on the front of the module. Two of these ports provide serial interfaces to external devices. Port 1 is also used for firmware upgrades. The third on-board serial port is used as the Ethernet station manager port. All serial ports are isolated.

### Protocols Supported

Protocol	Port 1 (COM 1)	Port 2 (COM 2)	Station Mgr
RTU (slave)	Yes	Yes	No
SNP Slave	Yes	Yes	No
Serial I/O	Yes	Yes	No
Firmware Upgrade	RX7i in STOP/No I/O mode		No
Message Mode (C Runtime Library Functions: serial read, serial write, sscanf, sprintf)	Yes	Yes	No

### Serial Port Baud Rates and Functions

Protocol	Port 1 (RS-232)	Port 2 (RS-485)	Station Mgr (RS-232)
Modbus RTU Slave protocol	1200, 2400, 4800, 9600, 19.2K, 38.4K, 57.6K, 115.2K		not supported
Message	1200, 2400, 4800, 9600, 19.2K, 38.4K, 57.6K, 115.2K		1200, 2400, 4800, 9600, 19.2K, 38.4K, 57.6K, 115.2K (Default: 9600)
Firmware Upgrade via Winloader	2400, 4800, 9600, 19.2K, 38.4K, 57.6K, 115.2K		not supported
SNP Slave	1200, 2400, 4800, 9600, 19.2K, 38.4K, 57.6K, 115.2K		not supported
Serial I/O	1200, 2400, 4800, 9600, 19.2K, 38.4K, 57.6K, 115.2K		not supported

## Serial Cable Lengths and Shielding

The connection from a CPU serial port COM1 to the serial port on a computer or other serial device requires a serial cable. This connection can be made with the IC200CBL001 cable kit or you can build cables to fit the needs of your particular application. See the *PACSystems CPU Reference Manual*, GFK-2222 for more information on serial communications, cables, and converters.

Maximum cable lengths (the total length from the CPU to the last device attached to the serial cable) are:

- Port 1 (RS-232) – 15 meters (50 ft.), shielded cable optional
- Port 2 (RS-485) – 1200 meters (4000 ft.), shielded cable required
- Station Manager (RS-232) – 15 meters (50 ft.), shielded cable optional

### Port 1

Port 1 (COM 1), the lower left port, is RS-232 compatible and is optocoupler isolated. It has a 9-pin, female, D-sub connector with a standard pin out. This is a DCE (data communications equipment) port that allows a simple straight-through cable to connect with a standard AT-style RS-232 port.

The Port 1 indicator provides the status of serial port activity.

#### Port 1 RS-232 Signals

Pin Number	Signal Name	Description
1*	NC	No Connection
2	TXD	Transmit Data
3	RXD	Receive Data
4	DSR	Data Set Ready
5	0V	Signal Ground
6	DTR	Data Terminal Ready
7	CTS	Clear To Send
8	RTS	Request to Send
9	NC	No Connection

\* Pin 1 is at the bottom right of the connector as viewed from the front of the module.

### Port 2

Port 2 (COM 2), the top serial port, is RS-485 compatible and is optocoupler isolated. Port 2 has a 15-pin, female D-sub connector. This port does not support the RS-485 to RS-232 adapter (IC690ACC901). This is a DCE port.

The Port 2 indicator provides the status of serial port activity.

#### Port 2 RS-485 Signals

Pin No.	Signal Name	Description
1*	Shield	Cable Shield
2	NC	No Connection
3	NC	No Connection
4	NC	No Connection
5	NC	No Connection
6	RTS(A)	Differential Request to Send
7	0V	Signal Ground
8	CTS(B')	Differential Clear To Send
9**	RT	Resistor Termination
10**	RD(A')	Differential Receive Data
11	RD(B')	Differential Receive Data
12	SD(A)	Differential Send Data
13	SD(B)	Differential Send Data
14	RTS(B)	Differential Request To Send
15	CTS(A')	Differential Clear To Send

\* Pin 1 is at the bottom right of the connector as viewed from the front of the module.

\*\* Termination resistance for the RD A' signal should be connected on units at the end of the line. To make this termination, connect a jumper between pins 9 and 10 inside the 15-pin D-shell.

### Station Manager Port

The station manager port, labeled **STA MGR**, is RS-232 compatible, DCE, and isolated. It has a 9-pin, female, D-connector that accepts a standard straight-through cable (such as IC200CBL001) to connect with a standard AT-style RS-232 port. This port contains full use of the standard RS-232 signals for future use with point-to-point protocol.

#### Station Manager RS-232 Signals

Pin Number	Signal Name	Description
1*	DCD	Data Carrier Detect
2	TXD	Transmit Data
3	RXD	Receive Data
4	DSR	Data Set Ready
5	0V	Signal Ground
6	DTR	Data Terminal Ready
7	CTS	Clear To Send
8	RTS	Request to Send
9	RI	Ring Indicator

\* Pin 1 is at the bottom right of the connector as viewed from the front of the module.

### Station Manager Operation

The Ethernet Interface contains features that support LAN management activities such as network performance measurement, status information, and fault diagnosis. Some of these features are accessed via the Station Manager, a portion of the Ethernet Interface operating firmware that responds to user commands. The Station Manager operates locally via an ASCII terminal or terminal emulator connected to the dedicated Station Mgr (RS-232) serial port, or remotely over the Ethernet LAN. Refer to the *PACSystems TCP/IP Ethernet Communications Station Manager Manual*, GFK-2225 for complete information on the Station Manager.

Each RX7i Ethernet interface provides a dedicated RS-232 serial port for local Station Manager use. The Ethernet Interface does not use this port for firmware upgrades. See "Firmware Upgrades" on page 8 for firmware upgrade details.

### RJ-45 Ethernet Network Ports

**Caution**

**The two ports on the Ethernet interface must not be connected, directly or indirectly, to the same device. The hub or switch connections in an Ethernet network must form a tree and not a ring; otherwise duplication of packets and network overload may result.**

**Note:** The CPU module has two RJ-45 connectors but only one IP address.

Each RX7i Ethernet interface contains two eight-conductor RJ-45 shielded twisted pair Ethernet ports, labeled **Port 1** and **Port 2**, for connection to either a 10BaseT or 100BaseTX IEEE 802.3 network. Either shielded or unshielded twisted pair cable can be attached to a port. Each Ethernet port automatically senses whether it is connected to a 10BaseT or 100BaseTX network, half-duplex or full-duplex. The user does not configure the network type. (The automatic negotiation of speed and/or duplex mode can be overridden by using AUP settings.) Standard twisted pair Ethernet cable is used for connection to other devices. Category 5 cable is required for 100BaseTX operation.

Each network port automatically operates in normal or crossover mode. This capability allows directly wiring the Ethernet interface to another device without an intervening network hub/switch, and without a special crossover cable. This allows you to connect RX7i Ethernet interfaces in a daisy chain arrangement. Care should be taken when using daisy chaining, since power loss or reset at an Ethernet interface will cause loss of communication to devices

downstream from that Ethernet interface in the daisy chain. Restarting the Ethernet interface (using the Ethernet Restart pushbutton, for example) also disrupts daisy chain communication.

#### Ethernet Port Signals

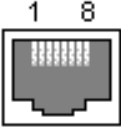
Pin No.	Ethernet 10BaseT 100BaseTX	Pin Position on RJ-45 Connector
1	Transmit +	
2	Transmit -	
3	Receive +	
4	N/A	
5	N/A	
6	Receive -	
7	N/A	
8	N/A	

\* Pin 1 is at the bottom of the connector as viewed from the front of the module.

### Configuration

The RX7i CPU and I/O system is configured with Proficy Machine Edition PLC-Logic Developer programming software.

The CPU verifies the actual module and rack configuration at power-up and periodically during operation. The actual configuration must be the same as the programmed configuration. Deviations are reported to the CPU alarm processor function for configured fault response. Refer to the *Proficy Machine Edition Logic Developer-PLC Getting Started Manual*, GFK-1918 and the online help for a description of configuration functions.

#### Ethernet Configuration

Essential network addresses for an Ethernet Interface are set up using the Machine Edition configuration software and stored to the CPU. These addresses must be properly configured before the Ethernet Interface can be used by your application. The configuration process is described in the *TCP/IP Ethernet Communications for PACSystems User's Manual*, GFK-2224.

For initial installation when there is no IP addressing information in the RX7i Ethernet Interface, Machine Edition (or Local Station Manager) is used to initially assign an IP address to the Ethernet Interface. Once set up, the Ethernet Interface retains the IP addressing information. The IP addressing information can be changed by storing a new configuration to the CPU.

## Advanced User Parameters

Advanced User Parameters (AUP) are internal operating parameters used by the Ethernet interface. For most applications, the default AUP should *not* be changed.

### Caution

**The IEEE 802.3 standard strongly discourages the manual configuration of duplex mode for a port (as would be possible using Advanced User Parameters). Before manually configuring duplex mode for a port using AUP, be sure that you know the characteristics of the link partner and are aware of the consequences of your selection. In the words of the IEEE standard: “Connecting incompatible DTE/MAU combinations such as full duplex mode DTE to a half duplex mode MAU, or a full-duplex station (DTE or MAU) to a repeater or other half duplex network, can lead to severe network performance degradation, increased collisions, late collisions, CRC errors, and undetected data corruption.”**

**Note:** If both speed and duplex mode of an Ethernet interface port are forced using AUP, that port will no longer perform automatic cable detection. This means that if the Ethernet interface port is connected to an external switch or hub port, a crossover cable must be used. If the Ethernet interface port is connected to the uplink port on an external switch or hub, or the Ethernet interface port is directly connected to another Ethernet device, a normal (straight-through) cable must be used.

## LEDs

The three CPU LEDs indicate the operating status of various CPU functions. During powerup, the LEDs are turned on and off in the initialization sequence. When the CPU has successfully completed initialization, the OK LED stays on. The RUN and EN LEDs are off or on, depending on the CPU state at last power-down.

The two port LEDs indicate activity on COM 1 and COM 2. The following table lists the CPU LED functions during normal operation.

The Ethernet Interface indicators consist of seven LEDs. All are single-color green LEDs controlled by the Ethernet interface.

- Module OK (EOK)
- LAN online (LAN)
- Status (STAT)
- Two activity LEDs (LINK)
- Two speed LEDs (100)

The **EOK**, **LAN**, and **STAT** LEDs are grouped together and indicate the state and status of the Ethernet interface.

*Each* Ethernet port has two green LED indicators, **100** and **LINK**. The Ethernet LED operation is described on page 7.

### CPU LED Operation\*

LED State			CPU Operating State
● On	⊕ Blinking	○ Off	
●	OK	On	CPU has passed its powerup diagnostics and is functioning properly.
○	OK	Off	CPU has failed.
⊕	OK	Blinking	CPU is in Stop/Halt mode.
●	RUN	On	CPU is in Run mode
○	RUN	Off	CPU is in Stop mode.
●	EN	On	Output scan is enabled.
○	EN	Off	Output scan is disabled.
⊕	Port 1 Port 2	Blinking Blinking	Signal activity on port.

\*After initialization sequence is complete.

**Ethernet LED Operation**

LED State			Ethernet Operating State
	● On	✚ Blinking	○ Off
✚	<b>EOK</b>	Blink error code	Hardware Failure
○	<b>LAN</b>	Off	
○	<b>STAT</b>	Off	
✚	<b>EOK</b>	Fast Blink	Performing Diagnostics
○	<b>LAN</b>	Off	
○	<b>STAT</b>	Off	
✚	<b>EOK</b>	Slow Blink	Waiting for Ethernet configuration from CPU
○	<b>LAN</b>	Off	
○	<b>STAT</b>	Off	
✚	<b>EOK</b>	Slow Blink*	Waiting for IP Address
● ✚ ○	<b>LAN</b>	On/Traffic/Off	
✚	<b>STAT</b>	Slow Blink*	
(* EOK and STAT blink in unison)			
● ✚ ○	<b>EOK</b>	On	Operational
	<b>LAN</b>	On/Traffic/Off	
	<b>STAT</b>	On/Off	
✚	<b>EOK</b>	Slow Blink*	Software Load
✚	<b>LAN</b>	Slow Blink*	
✚	<b>STAT</b>	Slow Blink*	
(* All LEDs blink in unison)			

**EOK LED Operation**

The EOK LED indicates whether the Ethernet interface is able to perform normal operation. This LED is on for normal operation and flashing for all other operations. When a hardware or unrecoverable runtime failure occurs, the EOK LED blinks a two-digit error code identifying the failure. The LED first blinks to indicate the most significant error digit, then after a brief pause blinks again to indicate the least significant error digit. After a long pause the error code display repeats. For definitions of LED blink codes, refer to the *TCP/IP Ethernet Communications for PACSystems User's Manual, GFK-2224*.

**LAN LED Operation**

The LAN LED indicates access to the Ethernet network. During normal operation and while waiting for an IP address, the LAN LED blinks to indicate network activity. This LED remains on when the Ethernet interface is not actively accessing the network but the network is available, and it is off if network access is not available. The definition of the network being available as indicated by this LED is that the Ethernet physical interface is available and one or both of the Ethernet ports is connected to an active network.

**STAT LED Operation**

The STAT LED indicates the condition of the Ethernet interface in normal operational mode. If the STAT LED is off, an event has been entered into the exception log and is available for viewing via the Station Manager interface. The STAT LED is on during normal operation when no events are logged.

In the other states, the STAT LED is either off or blinking and helps define the operational state of the module.

**Ethernet Port LEDs Operation (100Mb and Link/Activity)**

Each of the two Ethernet ports has two green LED indicators, **100** and **LINK**. The **100** LED indicates the network data speed (10 or 100 Mb/sec). This LED is illuminated if the network connection is 100 Mbps.

The **LINK** LED indicates the network link status and activity. This LED is illuminated when the link is physically connected and blinks when traffic is detected at the port. Note that traffic at the port does not necessarily mean that traffic is present at the RX7i Ethernet interface, since the traffic may be going between ports of the switch.

### ***Ethernet Restart Pushbutton***

This pushbutton is used to manually restart the Ethernet firmware without power cycling the entire control system. It is recessed to prevent accidental operation.

#### ***LED Operation during Restart***

When the Ethernet firmware is manually restarted by the Ethernet pushbutton in any state, the EOK, LAN and STAT LEDs are briefly turned on in unison as an LED test. These three LEDs are turned on for ½ second and are then turned off when the firmware is restarted. The Ethernet port LEDs are not affected by a manual restart of the Ethernet firmware.

The LED test is performed only upon a manual pushbutton restart; there is no LED test when the Station Manager initiates a restart.

### ***Ethernet Global Data (EGD)***

Each RX7i CPU supports up to 255 simultaneous Ethernet Global Data (EGD) exchanges across all Ethernet interfaces in the PLC. EGD exchanges must be configured in the programming software and stored into the CPU. The EGD configuration can also be loaded from the CPU into the programming software. Both produced and consumed exchanges can be configured. RX7i CPUs support using only part of a consumed EGD exchange, and EGD exchange production and consumption to the broadcast IP address of the local subnet.

The RX7i CPU supports 2msec EGD exchange production and timeout resolution. RX7i EGD exchanges can be

configured for a production period of 0, indicating the exchange is to be produced every output scan. These “as fast as possible” exchanges are not produced more often than 2msec. RX7i CPUs support enhanced EGD freshness, providing better EGD timeliness than Series 90-70 CPU products.

During EGD configuration, RX7i Ethernet interfaces are identified by their Rack/Slot location.

### ***User Web Pages (Web Server)***

The CPU Ethernet Interface provides basic remote control system monitoring from a web browser and allows a combined total of up to 16 web server and FTP connections. The CPU Ethernet interface contains a basic set of predefined PLC web pages that display Reference Table data, PLC Fault Table contents, and IO Fault Table contents.

### ***Firmware Upgrades***

The CPU and its Ethernet interface receive their firmware upgrades through a CPU serial port (COM 1 or COM 2). Since you are connecting directly to the CPU, there is no need to specify the Rack/Slot location. During the firmware upgrade the CPU and Ethernet modules are presented as a single entity. WinLoader seamlessly upgrades first the CPU firmware and then the Ethernet firmware without user intervention.

**Specifications \***

Battery Memory retention	5 years at 20°C (68°F) 40 days nominal without applied power.
Program storage	Up to 10 Mbytes of battery-backed RAM 10 Mbytes of non-volatile flash user memory
Current required from 5V bus	CPE010: 3.2 Amps nominal CPE020: 4.5 Amps nominal
Operating Temperature	CPE010: 0 to 50°C (32°F to 122°F) 0 to 60°C (32°F to 140°F) with fan tray CPE020: 0 to 60°C (32°F to 140°F) with fan tray, required
Floating point	Yes
Boolean execution speed, typical CPE010 CPE020	0.33ms per 1000 Boolean contacts/coils 0.14ms per 1000 Boolean contacts/coils
Time of Day Clock accuracy	Maximum of 9 seconds per day
Elapsed Time Clock (internal timing) accuracy	0.01% maximum
Embedded communications	RS-232, RS-485, Ethernet interface
Ethernet Ports	Embedded auto-sensing 10/100 Mbps half/full duplex Ethernet interface
Serial protocols supported	Modbus RTU Slave, SNP, Serial I/O
VME Compatibility	System designed to support the VME64 standard ANSI/VITA 1
Program blocks	Up to 512 program blocks. Maximum size for a block is 128KB.
Memory	%I and %Q: 32Kbits for discrete %AI and %AQ: configurable up to 32Kwords %W: configurable up the maximum available user RAM Symbolic: configurable up to 10Mbytes
* For environmental specifications and compliance to standards (for example, FCC or European Union Directives), refer to Appendix A of the PACSystems RX7i Installation Manual, GFK-2223.	

**Ordering Information**

<b>Description</b>	<b>Catalog Number</b>
RX7i VME 300Mhz CPU	IC698CPE010
RX7i VME 700Mhz CPU	IC698CPE020
Lithium Battery pack	IC698ACC701
Rack Fan Assembly, 120VAC	IC697ACC721
Rack Fan Assembly, 240VAC	IC697ACC724
Rack Fan Assembly, 24VDC	IC697ACC744
RX7i PLC Power Supply, 85 to 264 VAC at 47 to 63 Hz Input, 100 watt output	IC698PSA100
RX7i PLC Power Supply, 85 to 264 VAC at 47 to 63 Hz Input, 350 watt output	IC698PSA350
[Optional] RS-232 cable; also Station Manager cable for Ethernet interface	IC200CBL001

**Note:** For Conformal Coat option, please consult the factory for price and availability.