



INSTRUCTION MANUAL

4 A SIL 3 Relay Output Module for NE Load,
DIN-Rail and Termination Board,
Model D5090S



Characteristics

General Description: The single channel Relay Output, D5090S is a relay module suitable for the switching of safety related circuits, up to SIL 3 level according to IEC 61508 for high risk industries. It provides isolation between input and output contacts.

Three mutually exclusive (by DIP-Switch programming) monitoring circuits are provided:

- 1) line input monitoring, to allow DCS/PLC line monitoring function: when enabled, the module permits a wide compatibility towards different DCS/PLC. Driving line pulse testing, executed by DCS/PLC, is permitted by a dedicated internal circuit, to prevent relay and LED flickering;
- 2) low voltage input monitoring: when enabled, the module reflects a high impedance state to the control unit when the driving voltage is below the specified threshold;
- 3) short circuit fault detection: when enabled, it allows DCS/PLC to detect short circuit fault of module.

D5090S provides two NO contacts for normally energized load and a NC contact for service purpose, in order to switch the NE load on both supply lines.

See the following pages for Functional Safety applications with related SIL value.

Mounting on standard DIN-Rail or on customized Termination Boards, in Safe Area or in Zone 2.

Technical Data

Input: 24 Vdc nom (21.6 to 27.6 Vdc) reverse polarity protected, ripple within voltage limits ≤ 5 Vpp.

The following monitoring circuits are mutually exclusive:

- 1) **Line input monitoring (DIP-Switch selectable):** to allow DCS/PLC line monitoring function (pulse test).
- 2) **Voltage monitoring (DIP-Switch selectable):** ≥ 21.6 Vdc for normal operation, ≤ 17 Vdc reflects a high impedance (≤ 10 mA consumption) to the control device.
- 3) **Short circuit fault detection (DIP-Switch selectable):** to allow DCS/PLC to detect short circuit fault of module.

Current consumption @ 24 V: 35 mA with relay energized and line input monitoring disabled, 45 mA with relay energized and line input monitoring enabled, typical.

Power dissipation: 0.85 W with 24 V input voltage, relay energized and line input monitoring disabled, 1.1 W with 24 V input voltage, relay energized and line input monitoring enabled, typical.

Isolation (Test Voltage): Input / All Outputs 2.5 KV ; Out 1 / Out 2: 500V.

Output: 1 voltage free SPDT relay contact identified with outputs: Out 1 (NO contact) terminals 7-11 and Service Load Out (NC contact) terminals 9-10;

1 voltage free SPST relay contact identified with output Out 2 (NO contact) terminals 8-12.

Terminals 7-11 (Out 1) and 8-12 (Out 2) are open when relay is de-energized, closed in energized relay condition.

Service load output (not SIL) at terminals 9-10 is normally close when relay is de-energized, open in energized relay condition.

Contact material: Ag Alloy (Cd free).

Contact rating: 4 A 250 Vac 1000 VA, 4 A 250 Vdc 120 W (resistive load).

DC Load breaking capacity:

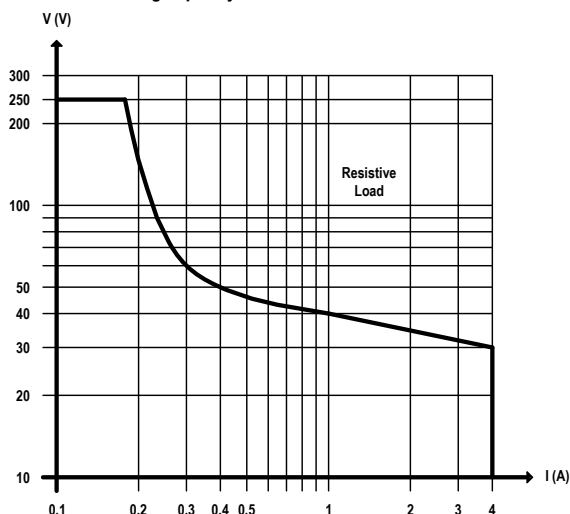

Mechanical / Electrical life: $5 * 10^6 / 3 * 10^4$ operation, typical.

Bounce time NO / NC contact: 3 / 8 ms, typical.

Frequency response: 10 Hz maximum.

Compatibility:



CE mark compliant, conforms to 94/9/EC Atex Directive and to 2004/108/CE EMC Directive.

Environmental conditions:

Operating: temperature limits - 40 to + 70 °C, relative humidity 95 %, up to 55 °C.

Storage: temperature limits - 45 to + 80 °C.

Safety Description:



ATEX: II 3G Ex nA nC IIC T4 Gc

IECEx: Ex nA nC IIC T4 Gc, non-sparking electrical equipment.

-40 °C \leq Ta \leq 70 °C.

Approvals: BVS 10 ATEX E 114 conforms to EN60079-15,

IECEx BVS 10.0072 X conforms to IEC60079-15.

Russia according to GOST 12.2.007.0-75, R 51330.0-99, R 51330.10-99, R 51330.14-99 2ExnAnCIIT4 X.

Ukraine according to GOST 12.2.007.0, 22782.0, 22782.3, 22782.5 2ExsIIT4 X.

TUV Certificate No. C-IS-204194-01, SIL 2 / SIL 3 conforms to IEC61508.

Mounting: T35 DIN-Rail according to EN50022 or on customized Termination Board.

Weight: about 120 g.

Connection: by polarized plug-in disconnect screw terminal blocks to accommodate terminations up to 2.5 mm².

Location: Safe Area/Non Hazardous Locations or Zone 2, Group IIC T4 installation.

Protection class: IP 20.

Dimensions: Width 12.5 mm, Depth 123 mm, Height 120 mm.

Ordering Information

Model: D5090S

DIN-Rail accessories: Cover and fix MCHP196

Front Panel and Features



- SIL 3 according to IEC 61508 for Tproof = 10 / 20 yrs (10 / 20 % of total SIF).
- SIL 2 according to IEC 61508 for Tproof = 20 yrs (10 % of total SIF).
- PFDavg (1 year) 7.01 E-06, SFF 99.60 % for NE Load.
- Installation in Zone 2.
- SIL 3 contact for NE load and contact for service purpose.
- Line input monitoring in-field DIP Switch selectable.
- Driving input voltage monitoring.
- Input/Output isolation.
- EMC Compatibility to EN61000-6-2, EN61000-6-4, EN61326-1, EN61326-3-1 for safety system.
- ATEX, IECEx, Russian and Ukrainian Certifications.
- Simplified installation using standard DIN-Rail and plug-in terminal blocks or customized Termination Boards.

Terminal block connections

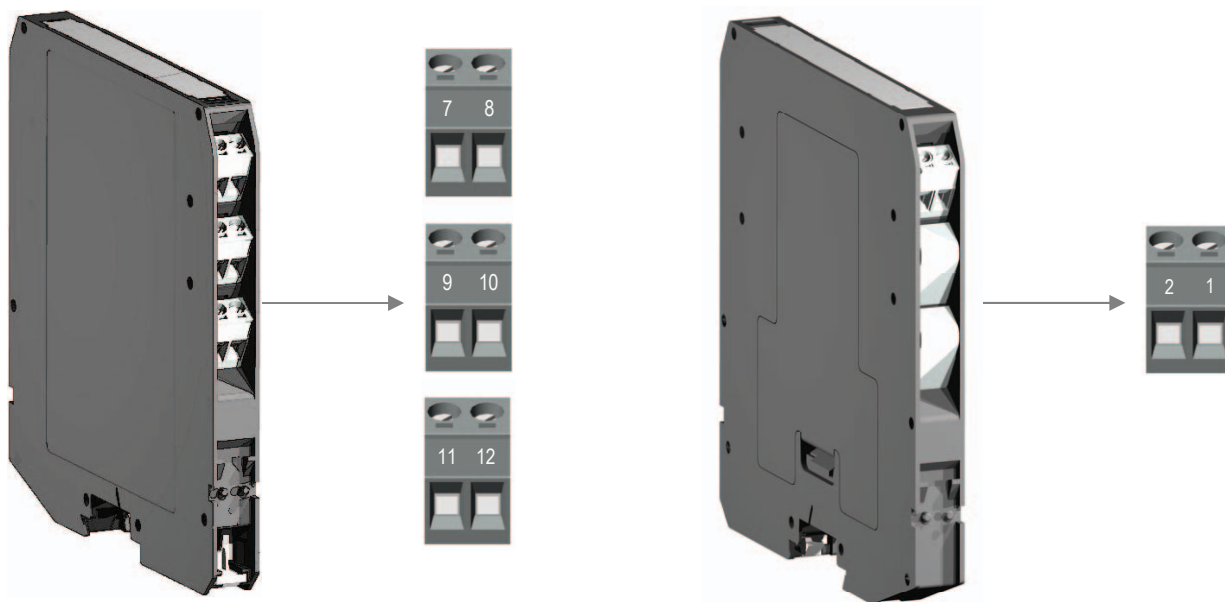

SAFE AREA

7 CM1 Common pole of Normally Open contact (Out 1)	1 + Input
8 NO1 pole of Normally Open contact (Out 2)	2 - Input
9 CM1 Common pole of Normally Closed contact (Service Load (Not SIL) out)	
10 NC1 pole of Normally Closed contact (Service Load (Not SIL) out)	
11 NO2 pole of Normally Open contact (Out 1)	
12 NO3 pole of Normally Open contact (Out 2)	

SAFE AREA, ZONE 2 GROUP IIC T4

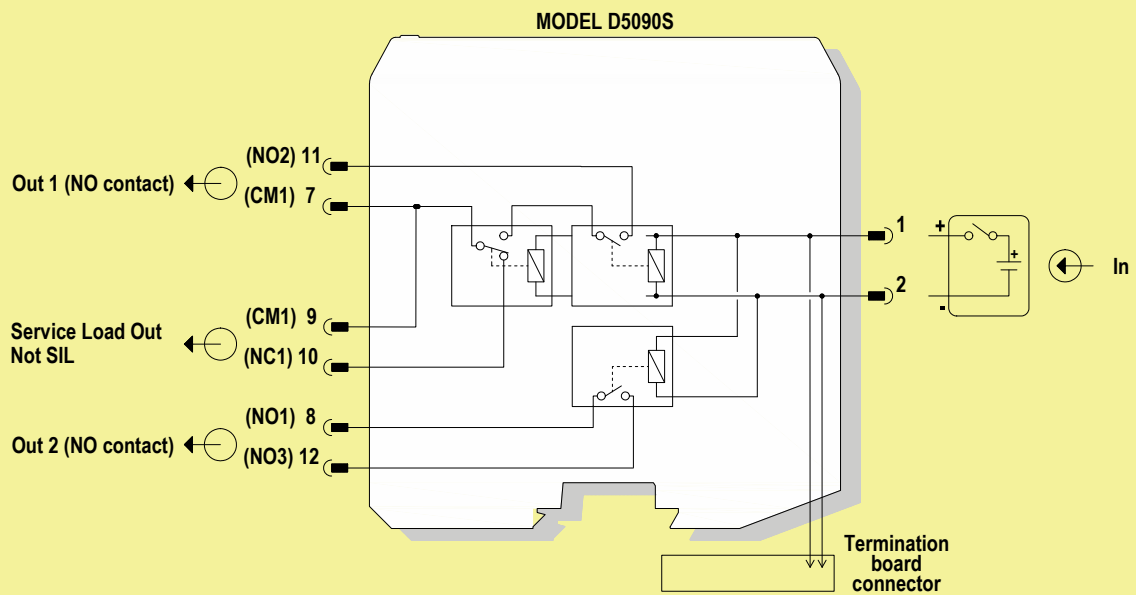

See the following pages for Functional Safety applications with related SIL value.

Relay contact shown in de-energized position.
Terminals 7-11 and 8-12 are open; terminals 9-10 are closed.

Application D5090S - SIL 3 Load Normally Energized Condition (NE) and Normally Energized Relay, with interruption of both load supply lines

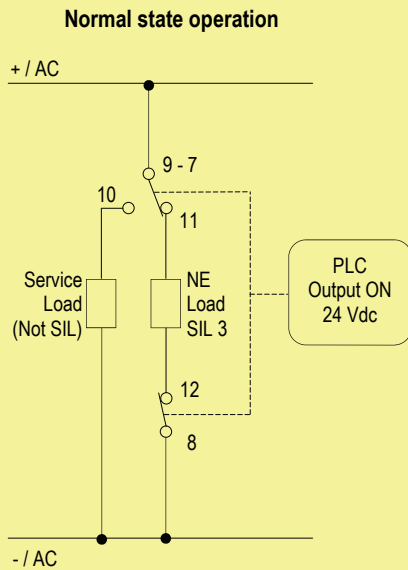

Contacts 7-11 and 8-12: in normal operation relays are energized, contacts are closed, NE load is energized.
Contact 9-10: in normal operation relay is energized, contact is open, service load for NE load is de-energized.

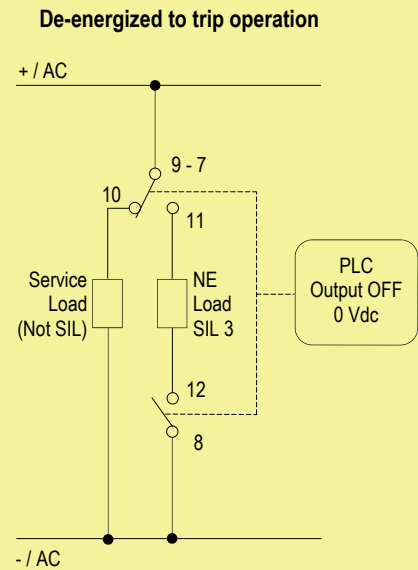

Contacts 7-11 and 8-12: the SIL 3 Safety Function is met when the relays are de-energized, contacts are open, NE load is de-energized.
Contact 9-10: in safe state the relay is de-energized, contact is closed, service load for NE load is energized.

Application D5090S - SIL 3 Load Normally Energized Condition (NE) and Normally Energized Relay, with interruption of only one load supply line

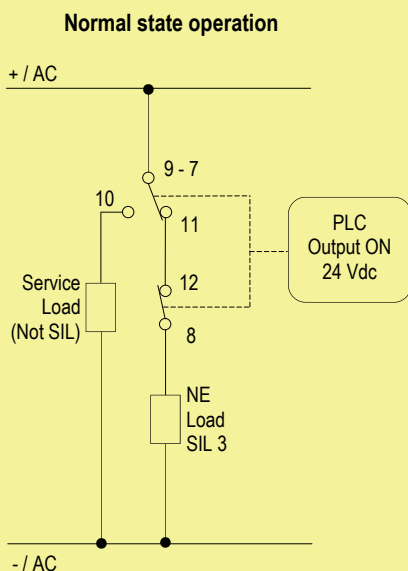

Contacts 7-11 and 8-12: in normal operation relays are energized, contacts are closed, NE load is energized.
Contact 9-10: in normal operation relay is energized, contact is open, service load for NE load is de-energized.

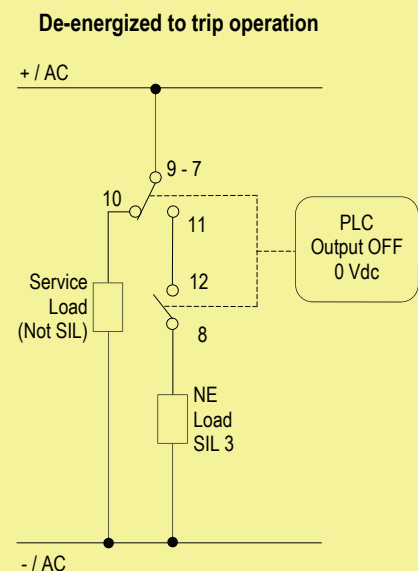

Contacts 7-11 and 8-12: the SIL 3 Safety Function is met when the relays are de-energized, contacts are open, NE load is de-energized.
Contact 9-10: in safe state the relay is de-energized, contact is closed, service load for NE load is energized.

To prevent relay contacts from damaging, connect an external protection (fuse or similar), chosen according to the relay breaking capacity diagram.

Warning

D5090S is an electrical apparatus installed into standard EN50022 T35 DIN-Rail located in Safe Area or Zone 2, Group IIC, Temperature Classification T4, Hazardous Area (according to EN/IEC60079-15) within the specified operating temperature limits Tamb - 40 to +70 °C.

D5090S must be installed, operated and maintained only by qualified personnel, in accordance to the relevant national/international installation standards (e.g. IEC/EN60079-14 Electrical apparatus for explosive gas atmospheres - Part 14: Electrical installations in hazardous areas (other than mines)), following the established installation rules.

De-energize power source (turn off power supply voltage) before plug or unplug the terminal blocks when installed in Hazardous Area or unless area is known to be nonhazardous.

Warning: substitution of components may impair Intrinsic Safety and suitability for Zone 2.

Warning: de-energize main power source (turn off power supply voltage) and disconnect plug-in terminal blocks before opening the enclosure to avoid electrical shock when connected to live hazardous potential.

Explosion Hazard: to prevent ignition of flammable or combustible atmospheres, disconnect power before servicing or unless area is known to be nonhazardous.

Failure to properly installation or use of the equipment may risk to damage the unit or severe personal injury.

The unit cannot be repaired by the end user and must be returned to the manufacturer or his authorized representative.

Any unauthorized modification must be avoided.

Operation

D5090S relay module is suitable for the switching of safety related circuits, providing isolation between the input and output contacts.

D5090S provides two NO contacts for normally energized load and a NC contact for service purpose, in order to switch the NE load on both supply lines.

See the previous pages for Functional Safety applications with related SIL value.

A "RELAY STATUS" yellow led lights when input is powered, showing that relay is energized.

Installation

D5090S is a relay output module housed in a plastic enclosure suitable for installation on T35 DIN-Rail according to EN50022 or on customized Termination Board.

D5090S unit can be mounted with any orientation over the entire ambient temperature range.

Electrical connection of conductors up to 2.5 mm² are accommodated by polarized plug-in removable screw terminal blocks which can be plugged in/out into a powered unit without suffering or causing any damage (**for Zone 2 installations check the area to be nonhazardous before servicing**).

The wiring cables have to be proportionate in base to the current and the length of the cable.

On the section "Function Diagram" and enclosure side a block diagram identifies all connections.

Identify the function and location of each connection terminal using the wiring diagram on the corresponding section, as an example (interruption of both NE load supply lines):

Connect positive input at terminal "1" and negative input at "2".

Connect positive or AC load supply line to CM1 Common pole (terminal "7" (for SIL 3 NE load) or "9" (for Not SIL Service Load)).

Connect SIL 3 Normally Energized (NE) Load at terminal "11" and "12".

Connect negative or AC load supply line at terminal "8" (for SIL 3 NE load).

Connect Not SIL Service Load at terminal "10" and to negative or AC load supply line.

Installation and wiring must be in accordance to the relevant national or international installation standards (e.g. IEC/EN60079-14 Electrical apparatus for explosive gas atmospheres Part 14: Electrical installations in hazardous areas (other than mines)), make sure that conductors are well isolated from each other and do not produce any unintentional connection.

Connect SPST relay contacts checking the load rating to be within the contact maximum rating (4 A 250 Vac 1000 VA, 4 A 250 Vdc 120 W resistive load).

To prevent relay contacts from damaging, connect an external protection (fuse or similar), chosen according to the relay breaking capacity diagram on data sheet.

The enclosure provides, according to EN60529, an IP20 minimum degree of mechanical protection (or similar to NEMA Standard 250 type 1) for indoor installation, outdoor installation requires an additional enclosure with higher degree of protection (i.e. IP54 to IP65 or NEMA type 12-13) consistent with the effective operating environment of the specific installation.

Units must be protected against dirt, dust, extreme mechanical (e.g. vibration, impact and shock) and thermal stress, and casual contacts.

If enclosure needs to be cleaned use only a cloth lightly moistened by a mixture of detergent in water.

Electrostatic Hazard: to avoid electrostatic hazard, the enclosure of D5090S must be cleaned only with a damp or antistatic cloth.

Any penetration of cleaning liquid must be avoided to prevent damage to the unit. Any unauthorized card modification must be avoided.

Relay output contact must be connected to load non exceeding category II overvoltage limits.

Warning: de-energize main power source (turn off power supply voltage) and disconnect plug-in terminal blocks before opening the enclosure to avoid electrical shock when connected to live hazardous potential.

Start-up

Before powering the inputs of unit check that all wires are properly connected, also verifying their polarity. Check conductors for exposed wires that could touch each other causing dangerous unwanted shorts. Enabling input, the "RELAY STATUS" yellow led must be lit and load circuit must be energized because relay output contacts (Out 1 and Out 2) are closed. Indeed, disabling input, the "RELAY STATUS" yellow led must be turned off and load circuit must be de-energized because relay output contacts (Out 1 and Out 2) are open.

Configuration

An eight position DIP Switch is located on component side of pcb in order to set four mutually exclusive configurations:

- 1) line input monitoring, to allow DCS/PLC line input monitoring function (driving line pulse testing);
- 2) low voltage input monitoring (UVLO—under voltage lock out): module reflects a high impedance state to the control unit when the driving voltage is below the specified threshold;
- 3) short circuit fault detection: it allows DCS/PLC to detect short circuit fault of module;
- 4) T-proof relay testing.

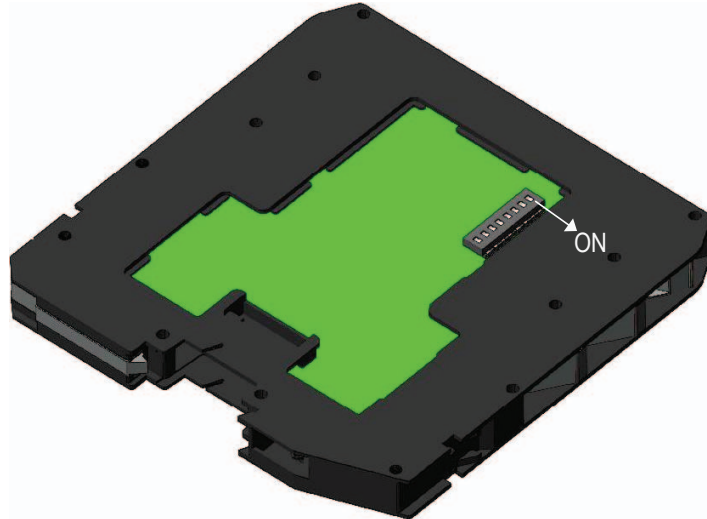

DIP switch configurations:

1) line input monitoring:

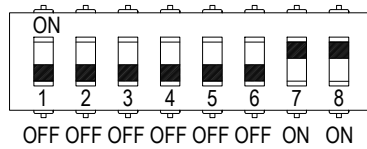

2) low voltage input monitoring:

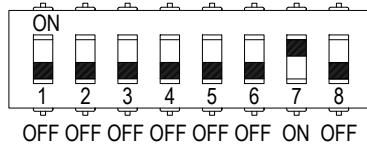

3) short circuit fault detection:

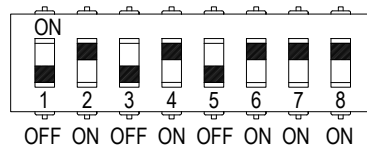

4) T-proof relay testing:

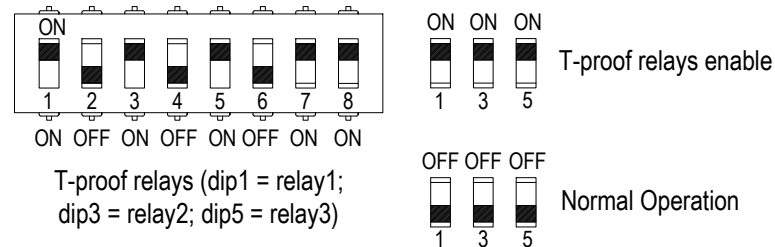

Please, see next page for testing procedure at T-proof.

WARNING: after T-proof test, dip-switch 1-3-5 must be set to “OFF” position for normal operation.

Testing procedure at T-proof

The proof test shall be performed to reveal dangerous faults which are undetected by diagnostic. This means that it is necessary to specify how dangerous undetected faults, which have been noted during the FMEDA, can be detected during proof test. The Proof test consists of the following steps:

Steps	Action
1	Bypass the safety-related PLC or take other appropriate action to avoid a false trip when removing the unit for test.
2	<p>For the single channel, verify the input-to-output functionality: the output load is normally energized by supplying the input channel, while shutdown of the input channel de-energizes the load (safe state). The channel functionality must be verified for a min to max input voltage change (21.6 to 27.6 Vdc). In addition, the use of three relays for the single output channel, where the contacts are connected in series, requires to control the single coil by means of DIP-switches (n°1, 3, 5) and to check the ohmic continuity of the contacts, as described in the following procedure.</p> <ol style="list-style-type: none"> Do not supply the input channel (terminals "1"-2") of the unit under test and verify that the ohmic continuity at the Out 1 and Out 2 contacts (terminals "7"-11" and "8"-12") is absent (i.e. both the Out 1 contact (series connection of two relay contacts) and the Out 2 contact are open: 1st requisite is verified). For Out 1 contact, this condition could also be true if only one of two relay contacts in series is open and other is blocked (for welding) into closed or open position: this will be verified by testing the channel when input is supplied, as described in the point 3 of the procedure. Instead, the presence of ohmic continuity at the Out 1 implies that both relay contacts in series are blocked (for welding) into closed position, while the presence of ohmic continuity at the Out 2 implies that the relay contact is blocked (for welding) into closed position. Supply the input channel (terminals "1"-2") of the unit under test and verify that the ohmic continuity at the Out 1 and Out 2 contacts (terminals "7"-11" and "8"-12") is present (i.e. both the Out 1 contact (series connection of two relay contacts) and the Out 2 contact are closed: 2nd requisite is verified). The absence of ohmic continuity at the Out 1 contact implies that one of two relay contacts in series is blocked (for welding) into open position: this could only be verified disassembling and individually testing each of two relay contacts. Instead, the absence of ohmic continuity at the Out 2 contact implies this relay contact is blocked (for welding) into open position. Always supplying the input channel (terminals "1"-2") of the unit under test, to verify if one of two relay contacts in series (Out 1) is blocked (for welding) into closed position, use internal DIP-switches (n°1 and 3) to put in short circuit one relay coil at a time (starting with the 1st coil by DIP-switch n°1, then going on with the 2nd one by DIP-switch n°3), verifying that the ohmic continuity is always absent between terminals "7"-11". The presence of ohmic continuity implies that a relay contact (the only one with de-energized coil) is blocked (for welding) into closed position.
3	Remove the bypass from the safety-related PLC or restore normal operation inserting the unit.

This test detects almost 100 % of all possible Dangerous Undetected failures in the relay module.

SIL Applications

D5090S Relay Output Modules for NE load

- Safety function**

The failure behaviour is described from the following definitions:

- fail-Safe State: is defined as the output load being de-energized;
 - fail Safe: failure mode that causes the module to go to the defined fail-safe state without a demand from the process;
 - fail Dangerous: failure mode that does not respond to a demand from the process (i.e. being unable to go to the defined fail-safe state), so that the output load remains energized;
 - fail "No Effect": failure mode of a component that is part of the safety function but that has no effect on the safety function.
- For the calculation of the SFF it is considered a safe undetected failure;
- fail "Not part": failure mode of a component which is not part of the safety function but part of the circuit diagram and is listed for completeness.
- When calculating the SFF this failure mode is not taken into account. It is also not considered for the total failure rate (safety function) evaluation.

- Failure rates table:

Failure category	Failure rates (FIT)
λ_{dd} = Total Dangerous Detected failures	0.00
λ_{du} = Total Dangerous Undetected failures	1.60
λ_{sd} = Total Safe Detected failures	0.00
λ_{su} = Total Safe Undetected failures	400.40
↳ Safe Undetected failures	285.80
↳ "No Effect" failures	114.60
$\lambda_{tot\ safe}$ = Total Failure Rate (Safety Function) = $\lambda_{dd} + \lambda_{du} + \lambda_{sd} + \lambda_{su}$	402.00
$\lambda_{not\ part}$ = "Not Part" failures	0.00
$\lambda_{tot\ device}$ = Total Failure Rate (Device) = $\lambda_{tot\ safe} + \lambda_{not\ part}$	402.00
MTBF (single channel) = $(1 / \lambda_{tot\ device}) + MTTR$ (8 hours)	284 years
$MTTF_S$ (Total Safe) = $1 / (\lambda_{sd} + \lambda_{su})$	285 years
$MTTF_D$ (Dangerous) = $1 / \lambda_{du}$	71347 years

- Failure rates table according to IEC 61508:

λ_{sd}	λ_{su}	λ_{dd}	λ_{du}	SFF
0.00 FIT	400.40 FIT	0.00 FIT	1.60 FIT	99.60%

- PFDavg vs T[Proof] table, with determination of SIL supposing module contributes 10% of entire safety function:

T[Proof] = 1 year	T[Proof] = 10 years	T[Proof] = 20 years
PFDavg = 7.01 E-06 Valid for SIL 3	PFDavg = 7.01 E-05 Valid for SIL 3	PFDavg = 1.40 E-04 Valid for SIL 2

- PFDavg vs T[Proof] table, with determination of SIL supposing module contributes 20% of entire safety function:

T[Proof] = 20 years
PFDavg = 1.40 E-04 Valid for SIL 3