

Pillar and wall-mounted slewing jib cranes

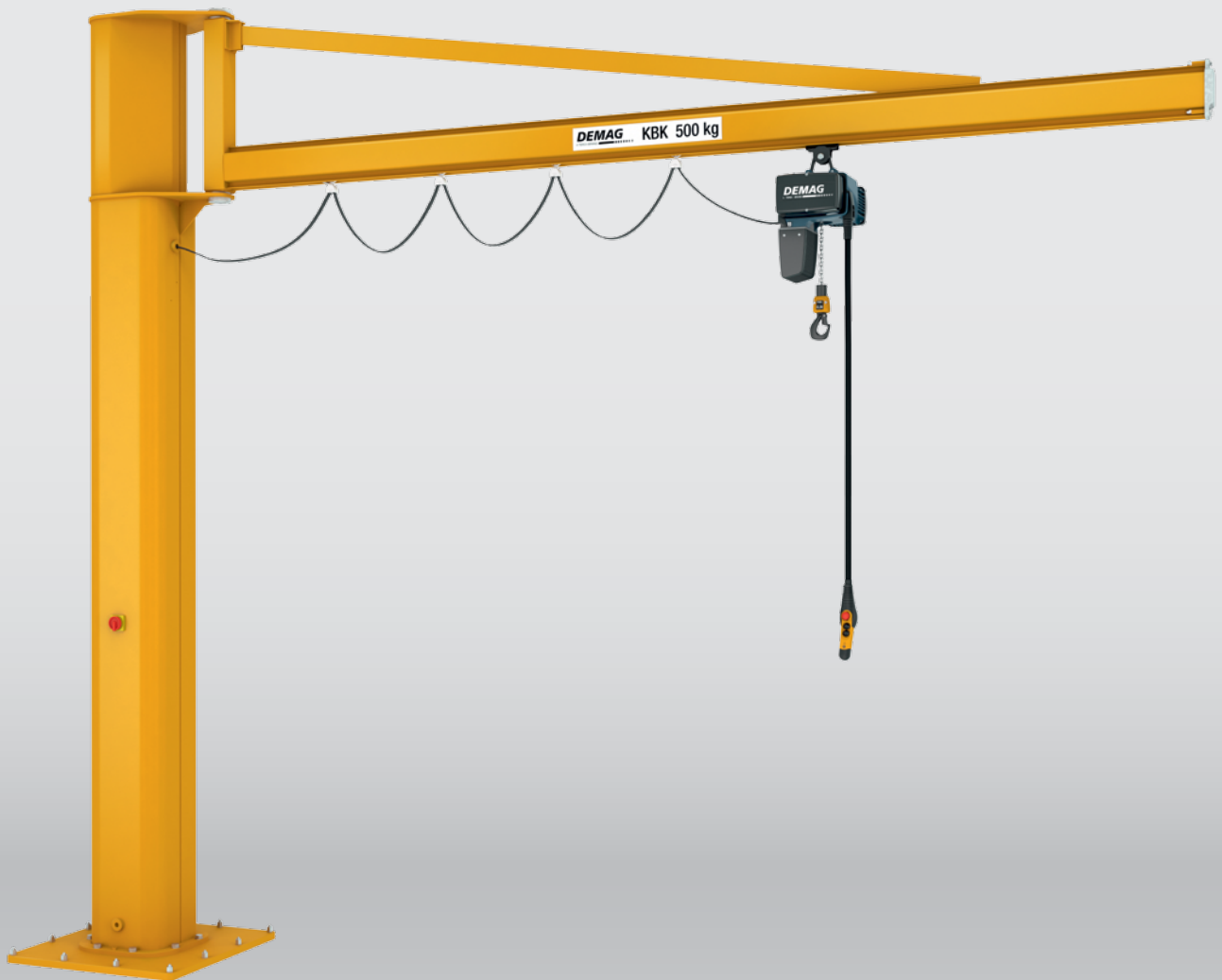

Move more

PRODUCTIVITY AND ERGONOMICS

System components and installations – everything from a single source

Demag slewing jib cranes ensure that all types of workpieces can be lifted and transported quickly and easily and deposited gently and precisely. They provide handling performance at machine tools and assembly stations, as well as in outdoor storage yards and on loading ramps. They are installed direct at the workplace and can be equipped with a wide selection of hoist units.

IMPROVED PRODUCTIVITY AND ERGONOMICS

Manual handling and combining or moving relatively light loads is often not only time-consuming, but also an ergonomic burden for employees.

Demag pillar and wall-mounted slewing jib cranes help to improve workplace ergonomics. We provide you with solutions to meet your specific requirements. For high efficiency and improved operating safety for workers, equipment and loads.

- Safe and reliable material flow
- Optimum workplace design
- Simple operation
- Ergonomic handling
- Complete solutions for your specific needs from a single source
- Highest possible quality standards
- Broad spectrum of load capacities and outreach dimensions



Move more

Productivity and ergonomics

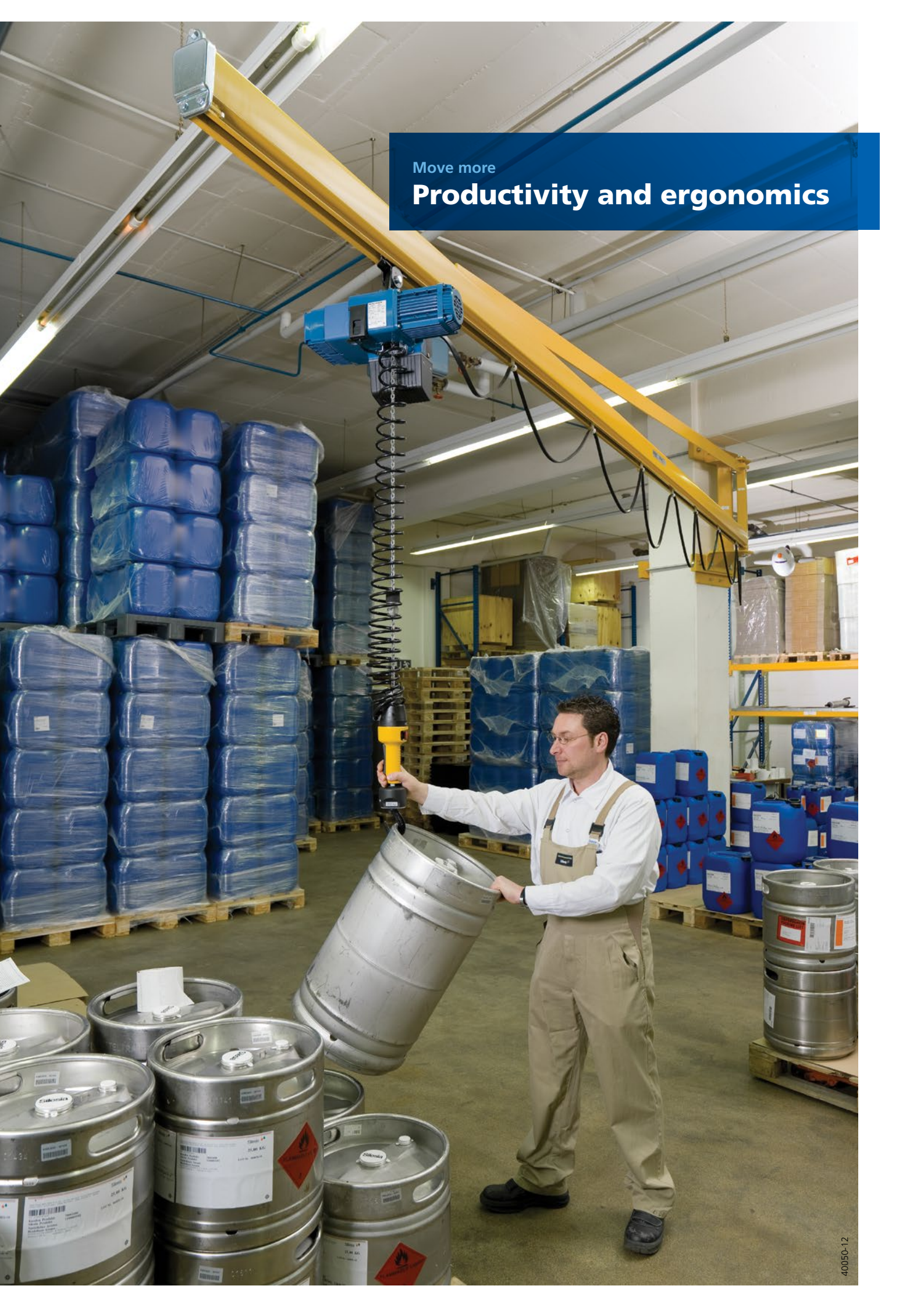

The right slewing jib crane for every application

Max. load capacity [kg]	Electric slewing	Pillar-mounted slewing jib cranes		Wall-mounted slewing jib cranes	
		Jib type/design	Max. outreach [m]	Jib type/design	Max. outreach [m]
1,000	-	KBK/fitted with brace	7	KBK/fitted with brace	7
		 Product details on page 8	 Product details on page 8		
2,000	Optional	I-beam/low-headroom design	7	I-beam/low-headroom design	7
		 Product details on page 9	 Product details on page 9		
2,000	Optional	I-beam/fitted with brace	8	I-beam/fitted with brace	8
		 Product details on page 10	 Product details on page 10		
10,000	Optional	I-beam/low-headroom design	12	I-beam/low-headroom design	12
		 Product details on page 11	 Product details on page 11		

The crane types shown on the following pages are designed for indoor operation as standard. The surfaces of steel superstructure components are coated to meet the requirements of corrosivity category C2M.

Demag Designer tool portal – Configure products to meet your needs

Configure a slewing jib crane solution to meet your needs with our Demag Designer system. When you have selected the product type, you can choose from a wide variety of available options to find the best possible solution for your requirements – a simple, reliable and plausible method.

Your direct access to our product configuration tools: www.demag-designer.com

YOUR BENEFITS:

- Simple handling
- Specify products to meet your needs
- Save your configuration
- Immediate results:
 - Product description
 - Technical data
 - CAD geometry data
 - Circuit diagrams
 - Documentation
- Online ordering via Demag Shop

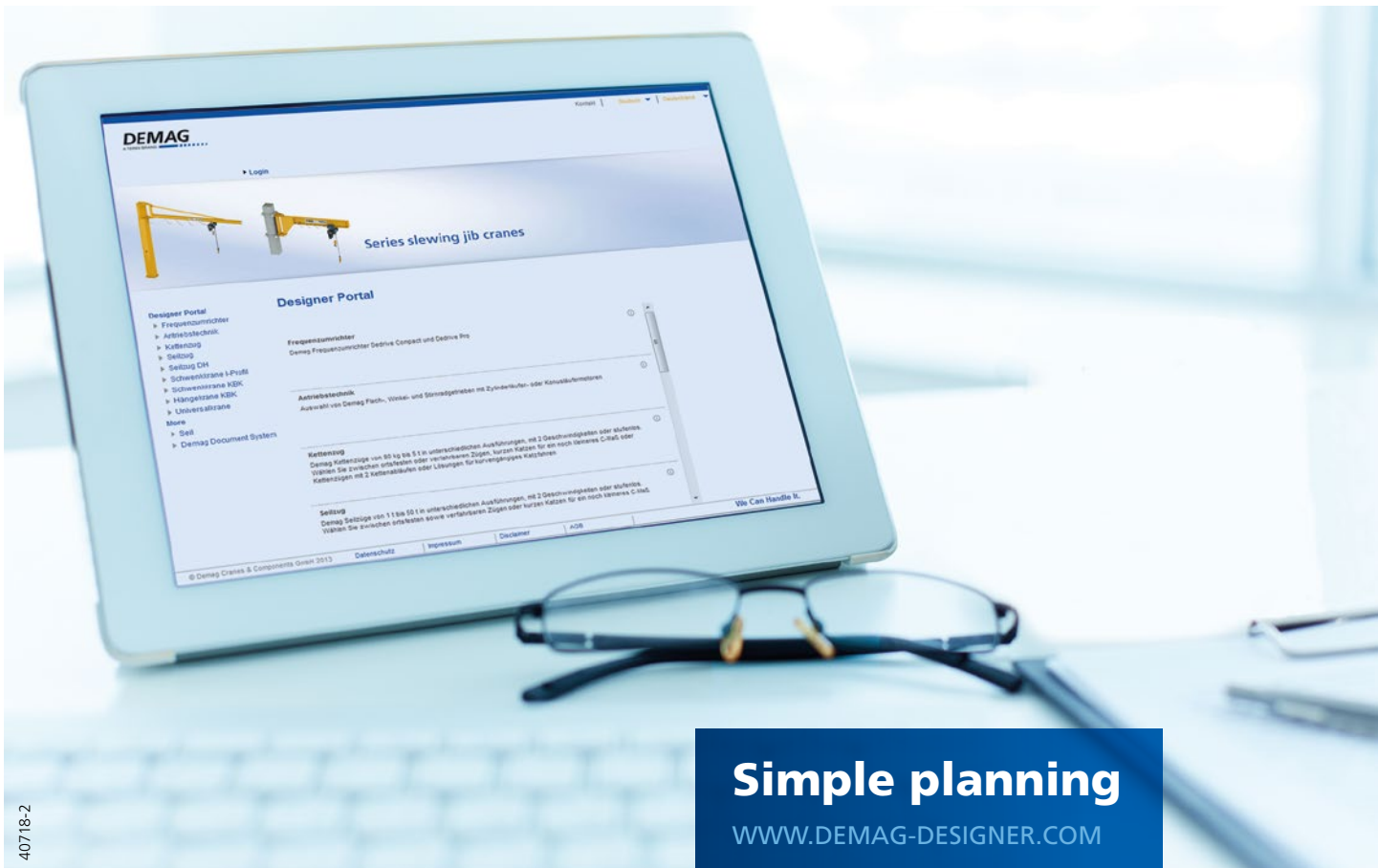

Simple planning

WWW.DEMAG-DESIGNER.COM

Pillar and wall-mounted slewing jib cranes

Advanced engineering to optimise workplaces in many industries. Highest possible quality standards for innovation and quality – for best possible customer benefits. Standard equipment includes the following sub-assemblies:

SÄULENKOPF

Hammerkopf-Design für größtmöglichen Schwenkwinkel. Höchste Präzision, da robotergeschweißt. Gleichbleibend hoher Qualitätsstandard.

PILLAR

Engineered square pillar for high rigidity and low deadweight.

POWER SUPPLY LINE

Flat trailing cable without any external fittings for minimum maintenance.

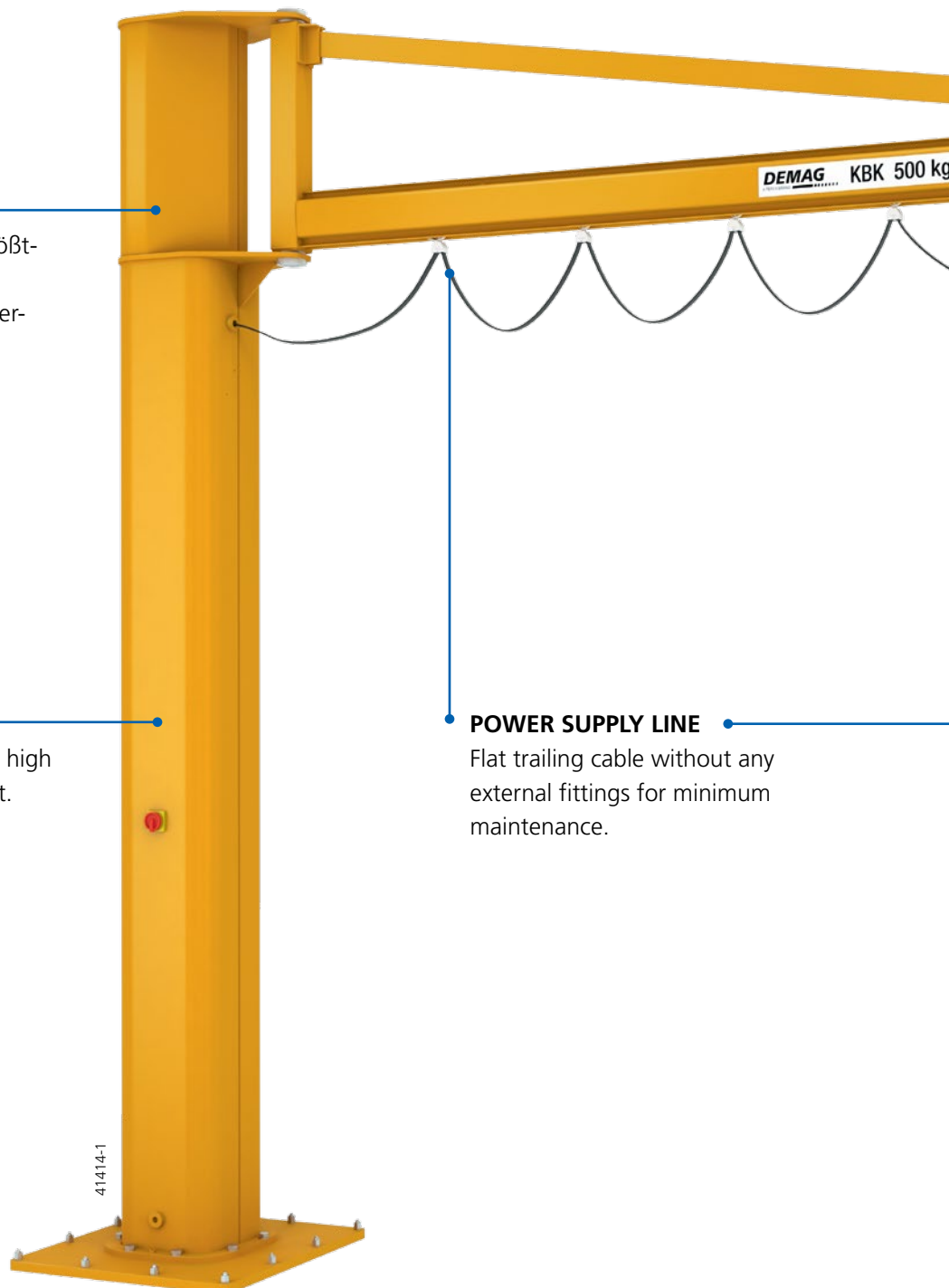

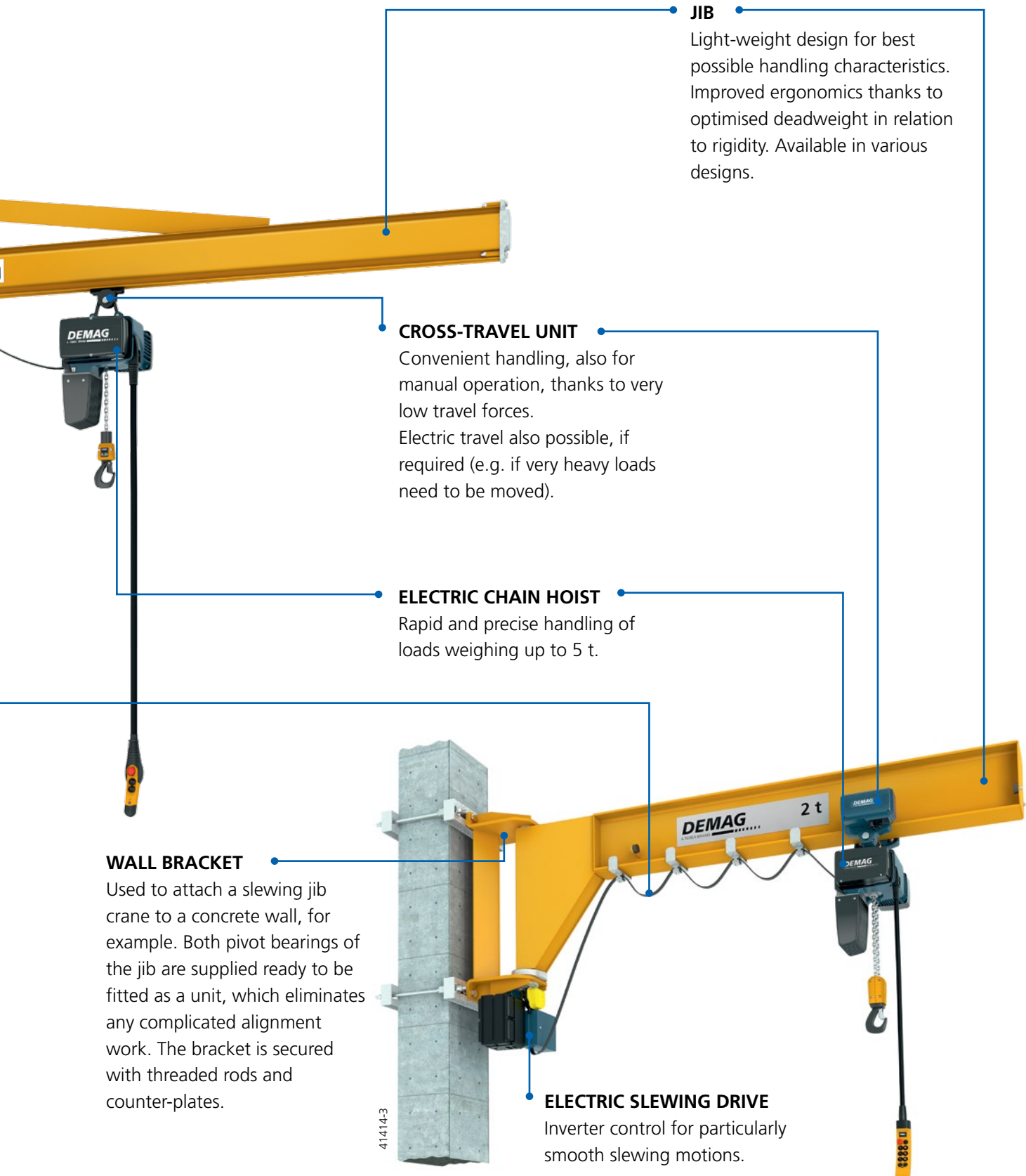

JIB

Light-weight design for best possible handling characteristics. Improved ergonomics thanks to optimised deadweight in relation to rigidity. Available in various designs.

CROSS-TRAVEL UNIT

Convenient handling, also for manual operation, thanks to very low travel forces. Electric travel also possible, if required (e.g. if very heavy loads need to be moved).

ELECTRIC CHAIN HOIST

Rapid and precise handling of loads weighing up to 5 t.

WALL BRACKET

Used to attach a slewing jib crane to a concrete wall, for example. Both pivot bearings of the jib are supplied ready to be fitted as a unit, which eliminates any complicated alignment work. The bracket is secured with threaded rods and counter-plates.

411414-3

ELECTRIC SLEWING DRIVE

Inverter control for particularly smooth slewing motions.

Light-weight design, low travel forces

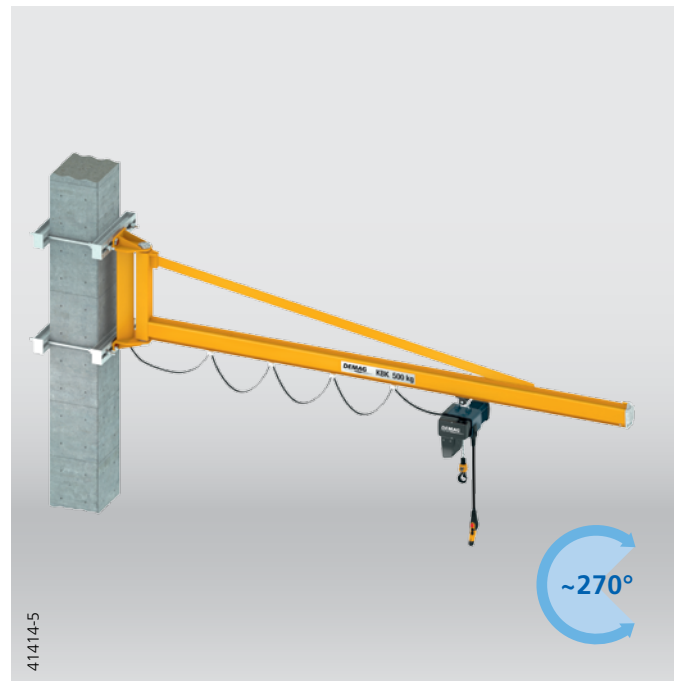

KBK JIB, FITTED WITH BRACE

Slewing jib cranes that have a braced KBK jib feature high load capacities and outreach in relation to their deadweight. Its low weight enables the jib to be moved with ease, even under load, for ergonomic handling. The proven KBK hollow section rail as the crane girder also provides for very low travel forces.

This light-weight design is ideally suited for all workplace material flow requirements and handling loads weighing up to 1,000 kg.

CAPACITY AND OUTREACH

Load capacity [kg]	Outreach [m]						
	2	3	4	5	6	7	
80							
125							
250							
500							
1,000							

MAIN TECHNICAL FEATURES

- Classification to DIN15018 H1B3
- Hollow-section jib



Long hook paths, low headroom dimension



I-BEAM JIB, LOW-HEADROOM DESIGN

Slewing jib cranes equipped with low-headroom I-beam jibs are suitable for universal applications over the entire load capacity range up to 2,000 kg. Thanks to their compact dimensions, they are the ideal solution for situations where long hook paths are needed in spite of a low ceiling height.

CAPACITY AND OUTREACH

Load capacity [kg]	Outreach [m]						
	2	3	4	5	6	7	
80							
125							
250							
500							
1,000							
1,600							
2,000							



MAIN TECHNICAL FEATURES

- Classification to DIN15018 H1B3
- I-beam jib

Long outreach, low deadweight

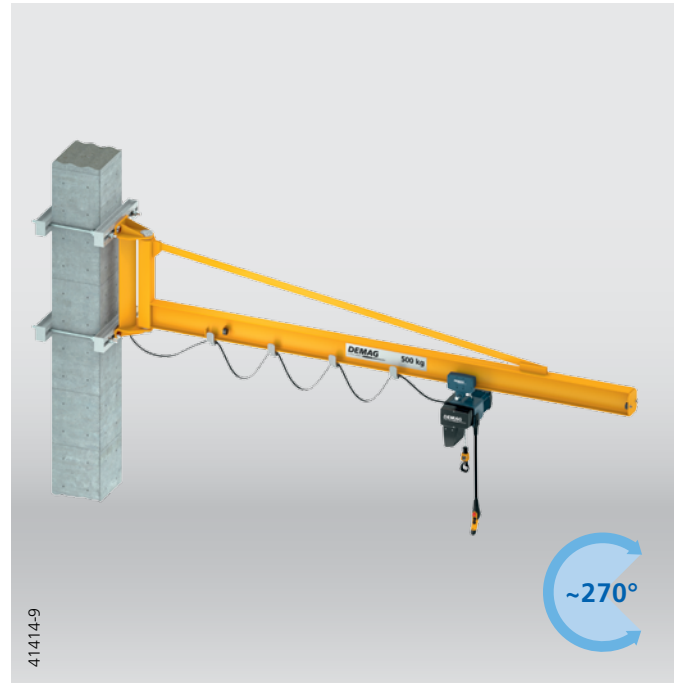

I-BEAM JIB, FITTED WITH BRACE

The braced jib design enables long outreach dimensions to be achieved for a low deadweight, which provides for easy and ergonomic manual operation for all outreach variants.

Smooth lifting and lowering motions as well as precise positioning with these slewing jib cranes enable you to handle sensitive and valuable loads gently and to avoid damage. For load capacities up to 2,000 kg.

CAPACITY AND OUTREACH

Load capacity [kg]	Outreach [m]							
	2	3	4	5	6	7	8	
80								
125								
250								
500								
1,000								
1,600								
2,000								

MAIN TECHNICAL FEATURES

- Classification to DIN15018 H1B3
- I-beam jib

High load capacities, large outreach dimensions

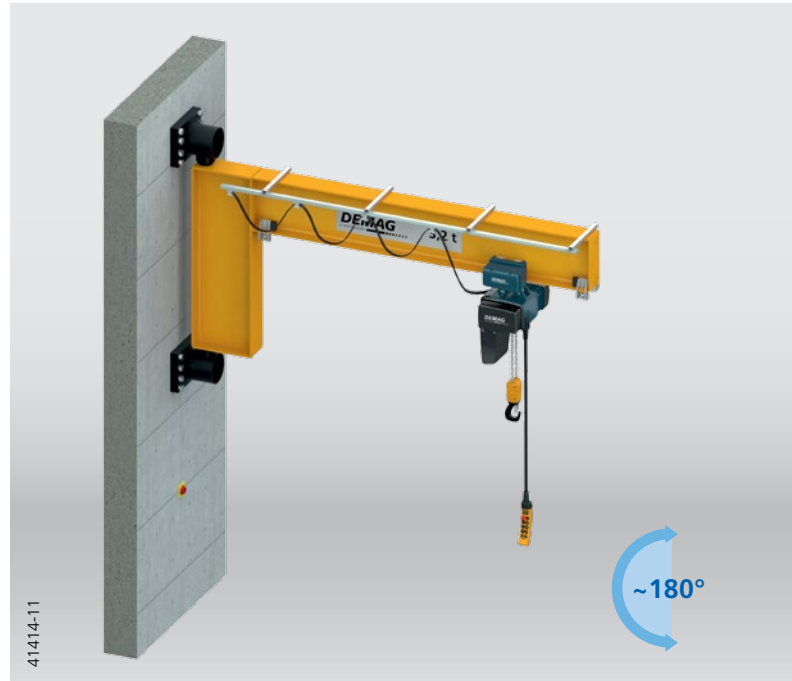

I-BEAM JIB, LOW-HEADROOM DESIGN

These slewing jib cranes offer high load capacities up to 10,000 kg for large outreach dimensions. The low-headroom jib provides for particularly long hook paths.

The unlimited slewing angle offered by the pillar-mounted slewing jib crane is a major benefit, especially for large working areas. However, the wall-mounted slewing jib cranes also provide a broad range of applications.



CAPACITY AND OUTREACH

Load capacity [kg] \ Outreach [m]	2	3	4	5	6	7	8	9	10	11	12
125											
250											
500											
1,000											
2,000											
3,200											
4,000											
5,000											
6,300											
8,000											
10,000											

MAIN TECHNICAL FEATURES

- Classification to DIN15018 H2B3
- I-beam jib
- Equipped with Demag chain or rope hoists as standard

Highly effective utilisation of space, two jibs

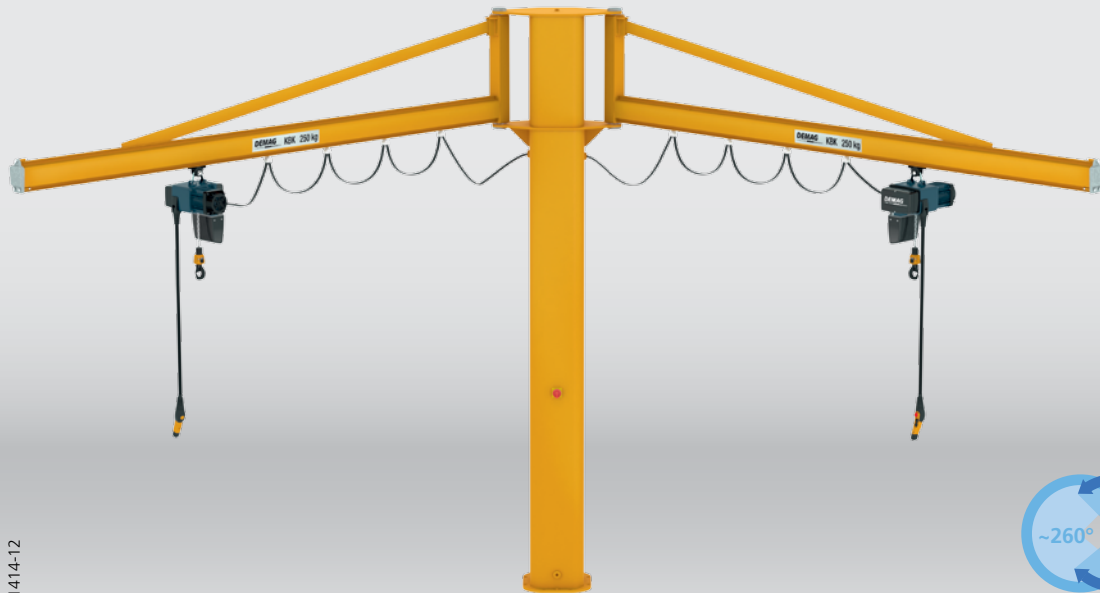

41141-12

KBK WITH TWO JIBS, FITTED WITH BRACE

Pillar-mounted slewing jib cranes fitted with two jibs are highly effective solutions: they take up the same space as slewing cranes that have one jib – but offer double the performance. Both jibs can be arranged opposite each other to create two neighbouring working areas. In this way, the efficiency of specific process sequences can be improved even further.

CAPACITY AND OUTREACH

Load capacity [kg]	Outreach [m]						
	2	3	4	5	6	7	
80/80							
125/125							
250/250							
500/500							
1,000/1,000							

MAIN TECHNICAL FEATURES

- Classification to DIN15018 H1B3
- Hollow-section jib



36517

Slewing motion options

- Hoists with electric travel
- Locking device to secure the jib in a specific position
- Electric slewing drive for particularly smooth slewing motions
- Radio control
- Alternative surface coatings – e.g. for outdoor operation
- Specific pillar heights for all pillar-mounted slewing jib cranes

SLEWING MOTION LIMITER



An adjustable slewing motion limiter can be installed to limit the slewing range of the jib, as required. The clamp-fitted design also enables it to be installed at a later date.

PILLAR CONNECTIONS

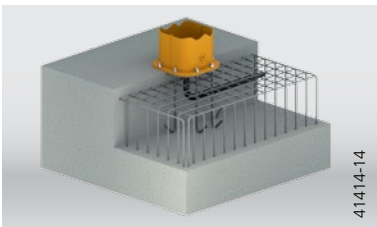

Anchors are used to fix pillars to the foundations. A template is used for precise alignment of the anchors with the mounting holes in the base of the pillar when the foundations are laid.

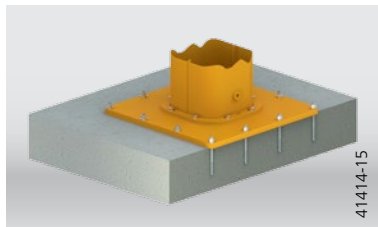

Anchor bolts are used to attach a pillar to an existing concrete floor. Chemical anchor bolts are first used to install an anchor plate to which the base of the crane pillar is then attached. This anchor variant is highly suited for relatively thin concrete floors that have a thickness ≥ 200 mm.

WALL MOUNTING ARRANGEMENT

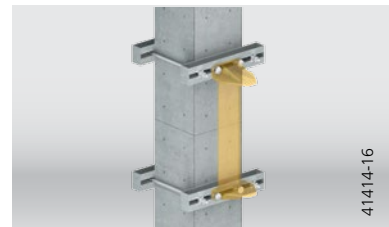

Pillar brackets can be used for simple attachment of wall-mounted slewing jib cranes to a wide range of pillar dimensions. They can be attached at the required height to all square-section pillars.

All wall and pillar connections for Demag slewing jib cranes offer maximum safety and ease of installation.

Demag hoists for every application

Demag hoist units are available with a wide range of load capacities, hoist speeds and features. They provide optimum ergonomic relief for employees and, at the same time, maximum safety and reliability wherever they are used.

COMPREHENSIVE STANDARD FEATURES FOR DEMAG CHAIN HOISTS:

- High level of safety thanks to 24 V contactor control and operating limit switches
- Flexibility thanks to two sizes of suspension bracket
- Simple commissioning thanks to plug connections
- Gearbox, brake and slipping clutch maintenance-free for up to 10 years
- Smooth and fast load handling with two lifting speeds
- Infinitely variable speed control option for even more precise handling
- Elapsed operating time counter and diagnostics interface provide information on the operating status



40343



39085



39233-5

39032-5

DEMAG DC-PRO CHAIN HOIST WITH CONTROL PENDANT

- Fatigue-free operation
- Convenient handling thanks to ergonomic housing design
- Comfortable working posture thanks to rapid height adjustability without any need for wiring
- Highly rugged design

DEMAG DCM-PRO MANULIFT

- Ergonomic single-handed load handling
- The chain hoist can be operated while the operator guides the load
- For right-hand and left-hand operation
- Quick-change coupling enables a wide variety of load handling attachments to be connected

DEMAG DC-PRO CHAIN HOIST WITH WIRELESS CONTROL

- The operator can vary his distance to the load for even more safety
- High versatility and availability
- Interference-free radio transmission
- Simple, wireless log-on of the hand-held transmitter
- Stop function according to safety category 3



389288

LOW-HEADROOM DEMAG DR ROPE HOIST

- Load capacities up to 10,000 kg
- 6 m hook path as standard
- Compact dimensions save space
- Precise positioning thanks to

- infinitely variable cross-travel speeds
- Smooth, low-sway load handling
- Convenient operation via integrated processor control
- High level of safety thanks to overload protection



Solutions to meet your needs

Assembly work



Serving machinery



Logistics



Slewing jib cranes operating outdoors



40883

The market leader working for you

We are a world leader for workplace crane solutions. Our engineering and service teams are recognised as the most experienced in the industry. Our slewing jib cranes are at home in all industries.

ALWAYS READY FOR OPERATION

One reason why our slewing jib cranes are so popular all over the world: they can also be installed with ease wherever other materials handling equipment cannot be used for structural reasons or due to the available space. If required, they can also be integrated in machinery and installations. To give you maximum flexibility both for planning and in daily operation.

MAXIMUM SAFETY, QUALITY AND RELIABILITY

The Demag crane experts are the right partner to ensure the long-term safety, reliability and availability of your crane installation. We offer you a wide range of valuable services to cover the entire life cycle of your installations. And the same applies to cranes, hoists, load handling attachments and related components of our Demag brand and to products supplied by other manufacturers. Everything from a single source – all over the world.

Terex MHPS GmbH

Wetter Site
 Ruhrstrasse 28 · 58300 Wetter, Germany
 E-mail: demag-info@terex.com

www.demagcranes.com

FAX SERVICE: +49 (0) 2335 92-7676

PLEASE SEND A QUOTATION/THE INFORMATION TO:

Company _____

PO Box/street _____

Town/post code _____

Contact _____

Telephone/extension _____

Fax _____

E-mail _____

Pillar-mounted slewing jib crane

Design _____

Jib type: fitted with brace
 low-headroom design

Weight of the load G_H : _____ kg
 Length of jib l : _____ m
 Highest hook position H : _____ mm
 Clear headroom $h + \text{min. } 100 \text{ mm}$: _____ mm

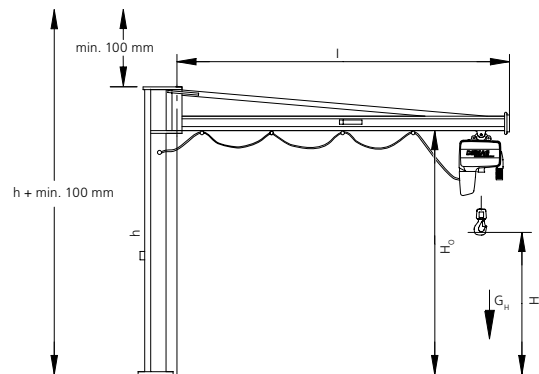

Please state dimensions

Additional information

Attachment: with anchor bolts
 anchor bolts on concrete floor

Slewing motion: manual electric
 Cross travel: manual electric

Hoist unit: _____

Wall-mounted slewing jib crane

Design _____

Jib type: fitted with brace
 low-headroom design

Weight of the load G_H : _____ kg
 Length of jib l : _____ m
 Highest hook position H : _____ mm
 Clear headroom $h + \text{min. } 100 \text{ mm}$: _____ mm

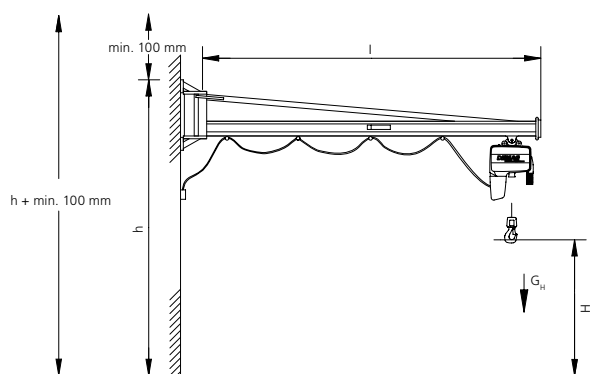

Please state dimensions

Additional information

Attachment: to steel pillar
 to reinforced concrete pillar
 to reinforced concrete wall

Mounting material: already available
 please offer

Slewing motion: manual electric
 Cross travel: manual electric

Hoist unit: _____

DEMAG

A TEREX BRAND



TEREX MATERIAL HANDLING

Terex MHPS GmbH is one of the world's leading suppliers of crane technology with Demag industrial cranes and crane components. The core competence of the Terex Material Handling business group lies in the development, design and production of technically sophisticated cranes, hoists and components and the provision of sales support and services for these products. Terex Material Handling manufactures at 19 locations on five continents and reaches its customers thanks to its presence in more than 60 countries.

Terex MHPS GmbH

Wetter Site

Ruhrstrasse 28 · 58300 Wetter, Germany

Phone: +49 (0) 2335 92-0

Fax: +49 (0) 2335 92-7676

E-mail: demag-info@terex.com

www.demagcranes.com