

DN 15 - DN 50; PN 16



Advantages / Benefits

- ▶ Easy System integration by Easy LINK provides low cost of ownership
- ▶ Easy commissioning due to multi-language, menu-guided operation
- ▶ TEACH-IN: automatic calibration in particular applications
- ▶ Shows both flow rate and volume (2 totalizers)
- ▶ Simulation: all output signals provided without real flow
- ▶ Options:
 - 2 Alarm relays
 - Pulse output on relay reed
 - Power supply 115/230 VAC
 - 9 VDC battery version
- ▶ Fittings available for all standard hydraulic interfaces

Design

The paddle-wheel flow transmitter for continuous flow measurement and batch control is specially designed for use in neutral, solid-free liquids.

The transmitter is made of a compact fitting and an electronic-module quickly and easily connected together by a bayonet.

The Burkert designed brass-fitting system (all international threaded port connections) ensures simple installation of the transmitters into all pipes from DN 15 to DN 50.

The display and menu-guided operating elements allow a customized adjustment of all measuring parameters:

- multi-language
- various engineering units
- customized measuring ranges
- teaching mode; simulation mode

Flow Transmitter

- 4...20 mA standard output signal
- Pulse output (NPN, PNP or reed),
- Local flow display,
- 2 totalizers display,
- 2 programmable thresholds (option)

Flow Switch

- 2 programmable thresholds

Stand Alone (Battery)

- Battery powered,
- 2 totalizers display,
- Local flow display,

Batch Controller

- 2 totalizers display,
- 2 programmable thresholds
- 3 Dosing modes:
 - Local
 - External (via binary inputs)
 - Time proportional (via PLC)

Applications

Flow Measurement & Dosing Control

Industrial water

Cooling water monitoring

Auxiliary plants

Irrigation

Ideal for industrial cold and hot water applications

bürkert
Easy Fluid Control Systems

Digital Flow Transmitter

for continuous flow measurement and batch control

Type 8035

Brass-INLINE

Design

The compact flow transmitter combines a flow sensor and an electronic board with display in an IP65 enclosure.

The sensor part consists of a transducer and an open-cell paddle-wheel.

The transmitter component converts the measured signal and displays the actual value. The output signals are provided via a 4-pole cable plug or via cable gland PG 13.5.

Principle of operation

When liquid flows through the pipe, the paddle-wheel is set in rotation inducing a measuring frequency in the transducer, which is proportional to the flow.

The flow transmitter 8035 can receive an optional power supply 230/115 VAC and is also available with 9 VDC battery power supply.

The transmitter measures a flow rate from 0.3 m/s (1.0 ft/s).

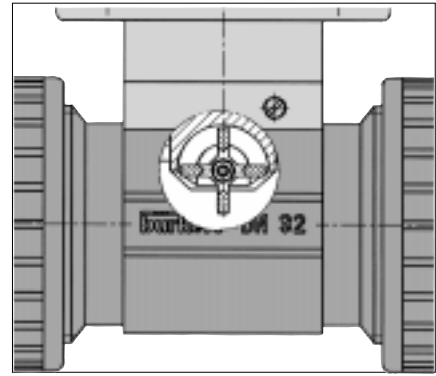

Installation

The flow transmitter is made of a compact fitting and an electronic module which can be quickly and easily connected by means of a Quarter Turn.

The recommended In- and Outflow straight pipe length should respect 10xD in and 3xD out.

According to pipe's design, necessary distances can be bigger or use a flow conditioner to obtain the best accuracy.

For more informations, please refer to EN ISO 5167-1.

The flow transmitter can be installed in either horizontal or vertical pipes.

The suitable pipe size is selected using the diagram on the next page. Pressure and temperature ratings must be respected according to the selected fitting material (see next page).

The flow transmitter is not designed for gas flow measurement.

Easy to install

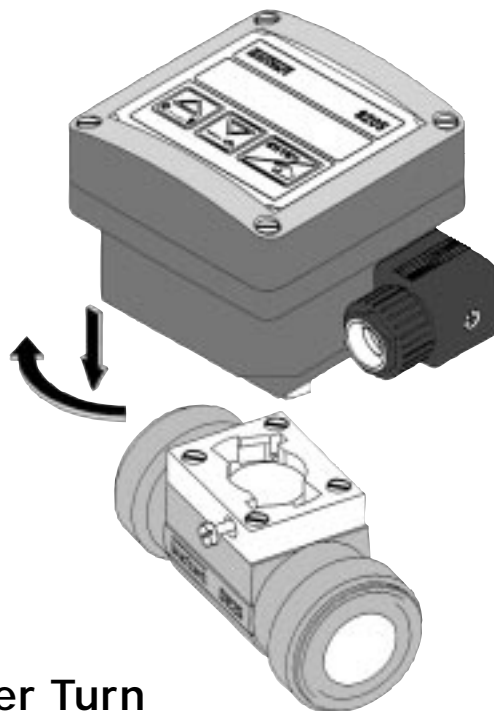

Burkert Quarter Turn

Operation / Commissioning

The device can be calibrated by means of the K-factor, or via the Teach-In function.

Customized adjustments, such as measuring range, engineering units, pulse output and filter are carried out on site.

Examples of fitting selection

The suitable pipe size is selected using the diagram below.

Example 1 :
Specification of nominal flow: 10 m³/h
Ideal flow velocity: 2...3 m/s
For these specifications, the diagram indicates a pipe size of DN 40.

Example 2 :
Specification of nominal flow: 50 gpm
Ideal flow velocity: 8 fps
For these specifications, the diagram indicates a pipe size of 1 1/2".

Diagram Flow-Pipe Size-Velocity

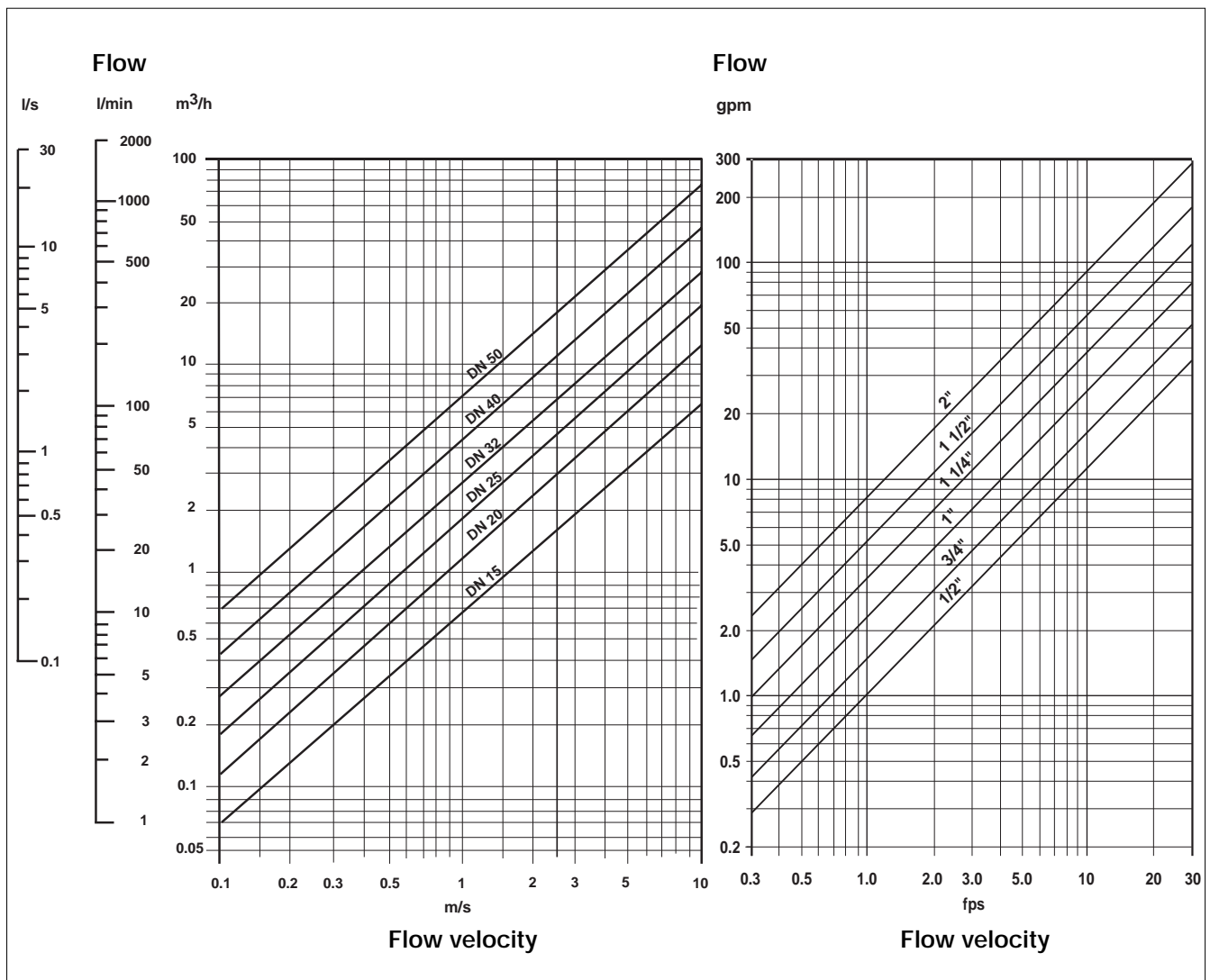

Operation and display

The operation is specified according to two or three levels:

Flow Transmitter :

- ▶ **Indication in operating mode**
 - flow
 - output current
 - main totalizer
 - daily totalizer and reset function
- ▶ **Parameter definition**
 - language
 - engineering units
 - K-factor / Teach-In function
 - measuring range 4...20 mA
 - pulse output
 - relay (option)
 - filter
 - reset of main totalizer
- ▶ **Test**
 - alteration of basic adjustment (offset, span)
 - frequency test of sensor
 - flow simulation (dry-run test operation)

Batch Controller :

- ▶ **Indication in operating mode**
 - main and daily totalizers and reset function
 - dosing amount
 - dosing mode
 - flow
- ▶ **Parameter definition**
 - language
 - engineering units
 - K-factor / Teach-In function
 - selection of batching mode
 - over-run correction
 - alarm
 - function mode of relays
 - reset of main totalizer
- ▶ **Test**
 - display of state of binary inputs
 - relay test
 - frequency test of sensor

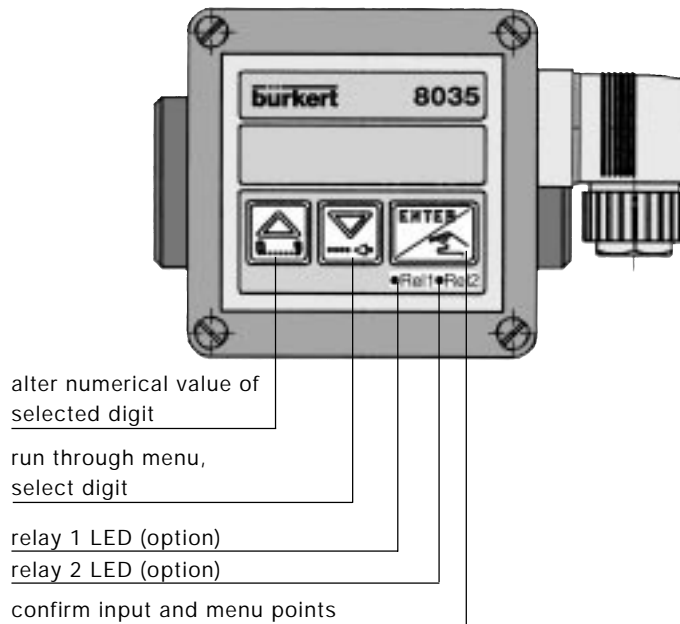

Flow Switch :

- ▶ **Indication in operating mode**
 - flow
- ▶ **Parameter definition**
 - language
 - engineering units
 - K-factor / Teach-In function
 - relay
 - filter
- ▶ **Test**
 - frequency test of sensor
 - flow simulation (dry-run test operation)

Stand Alone (Battery) :

- ▶ **Indication in operating mode**
 - main and daily totalizers with reset function
 - flow
- ▶ **Parameter definition**
 - language
 - engineering units
 - K-factor / Teach-In function
 - filter
 - reset of main totalizer

Technical data

General data

Pipe diameter from DN 15 to DN 50 (1/2" to 2")
 Measuring range 0.3 m/s to 10 m/s (1.0 fps to 33 fps)
 as from 3 l/min (DN15 pipe, 0,3 m/s flow velocity)
 as from 0.9 gpm (1/2" pipe, 1.0 fps flow velocity)

Measuring error

1. With In-line calibration (Teach-In):
 $\leq \pm 0.5\%$ o.F.S. (at 10 m/s) *
2. With standard mean K-factor:
 $\leq \pm (0.5\%$ o.F.S. + 2.5% o.R.) *

Linearity $\leq \pm 0.5\%$ o.F.S. (at 10 m/s) *
 Repeatability 0.4% o.R. *

Fluid temperature max. 0°C to 100°C (32 to 212°F)
 Ambient temperature 0°C to 60°C (32 to 140°F)
 Storage temperature 0°C to 60°C (32 to 140°F)
 Pressure class PN 16

Enclosure IP 65
 Fitting brass
 Sensor holder brass
 Paddle-wheel PVDF
 Axis and bearing Ceramic
 O-rings FPM standard
 Housing PC
 Front plate foil polyester

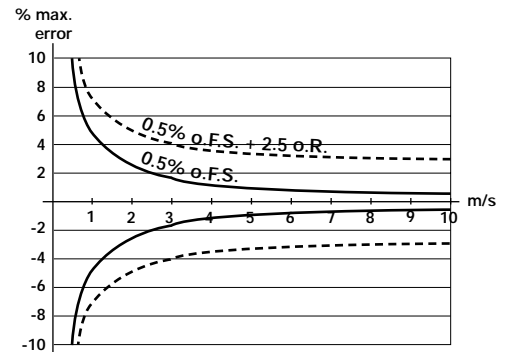

Specific data Flow Transmitter

Voltage supply 12...30 VDC
 Option: 115/230 VAC power supply
 Output signal 4...20 mA
 Load max. 900 Ω at 30V
 max. 500 Ω at 24V
 max. 100 Ω at 15V
 max. 800 Ω with power supply 115/230 VAC
 Pulse output Open collector NPN and PNP, 0...30 V, 100 mA, protected
 Option: relay Reed closing 0,1 sec., opening depending on flow rate 0,1 sec. min.
 max. 34 V, 0,2 A
 Relay output (option) 2 relays, freely programmable, 3 A, 230 V

Specific data Flow Switch

Voltage supply 12...30 VDC
 Option: 115/230 VAC power supply
 Relay output freely programmable, 3 A, 230 V

Specific data Batch Controller

Voltage supply 12...30 VDC
 Option: 115/230 VAC power supply
 Digital inputs 4 inputs, 5...30 VDC
 Digital output 1 input, Open collector NPN and PNP, 0...30 V, 100 mA, protected
 Relay output 2 relays, freely programmable, 3 A, 230 V

Specific data Stand Alone (Battery)

Voltage supply 9 VDC battery supply
 Autonomy 3...4 years with lithium batteries
 1...2 years with standard batteries

* Under reference conditions, i.e. measuring fluid = water, ambient and water temperature = 20 °C, applying the minimum inlet and outlet pipe straights, matched inside pipe dimensions
 o.R. = of reading
 o.F.S. = of full scale (10 m/s)

Dimensions [mm (inch)]

Internal threaded port connection

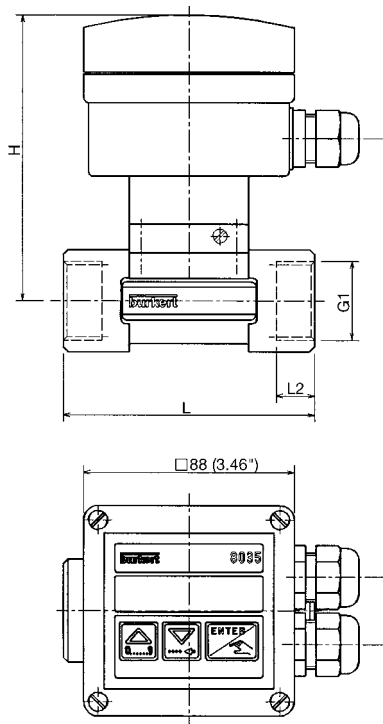

Dimensions G-Port connection

Port connection	DN	Variable dimensions [mm]		
		L	L2	H
(Dimension G1)				
G 1/2	15	85	16.0	122
G 3/4	20	95	17.0	119
G 1	25	105	23.5	120
G 1 1/4	32	120	23.5	123
G 1 1/2	40	130	23.5	127
G 2	50	150	27.5	134

Dimensions Rc-Port connection

Port connection	DN	Variable dimensions [mm]		
		L	L2	H
(Dimension G1)				
Rc 1/2	15	85	15.0	122
Rc 3/4	20	95	16.3	119
Rc 1	25	105	18.0	120
Rc 1 1/4	32	120	21.0	123
Rc 1 1/2	40	130	19.0	127
Rc 2	50	150	24.0	134

Dimensions NPT-Port connection

Port connection	DN	Variable dimensions [inch]		
		L	L2	H
(Dimension G1)				
NPT 9/16	15	3.35	0.67	4.81
NPT 3/4	20	3.74	0.72	4.69
NPT 1	25	4.14	0.71	4.73
NPT 1 1/4	32	4.73	0.83	4.85
NPT 1 1/2	40	5.12	0.79	5.00
NPT 2	50	5.91	0.95	5.28

External threaded port connection

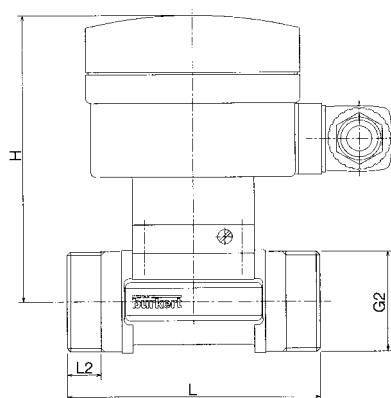

Dimensions [mm]

Port connection	DN	Variable dimensions [mm]		
		L	L2	H
(Dimension G2)				
G 3/4	15	84	11.5	122
G 1	20	94	13.5	119
G 1 1/4	25	104	14	120
G 1 1/2	32	119	18	123
M 55x2	40	129	19	127
M 64x2	50	149	20	134

Dimensions [inch]

Port connection	DN	Variable dimensions [inch]		
		L	L2	H
(Dimension G2)				
G 3/4	15	3.31	0.45	4.81
G 1	20	3.70	0.53	4.69
G 1 1/4	25	4.09	0.55	4.73
G 1 1/2	32	4.69	0.71	4.85
M 55x2	40	5.08	0.75	5.00
M 64x2	50	5.87	0.78	5.28

Digital Flow Transmitter

for continuous flow measurement and batch control

Type 8035

Brass-INLINE

Dimensions [mm (inch)]

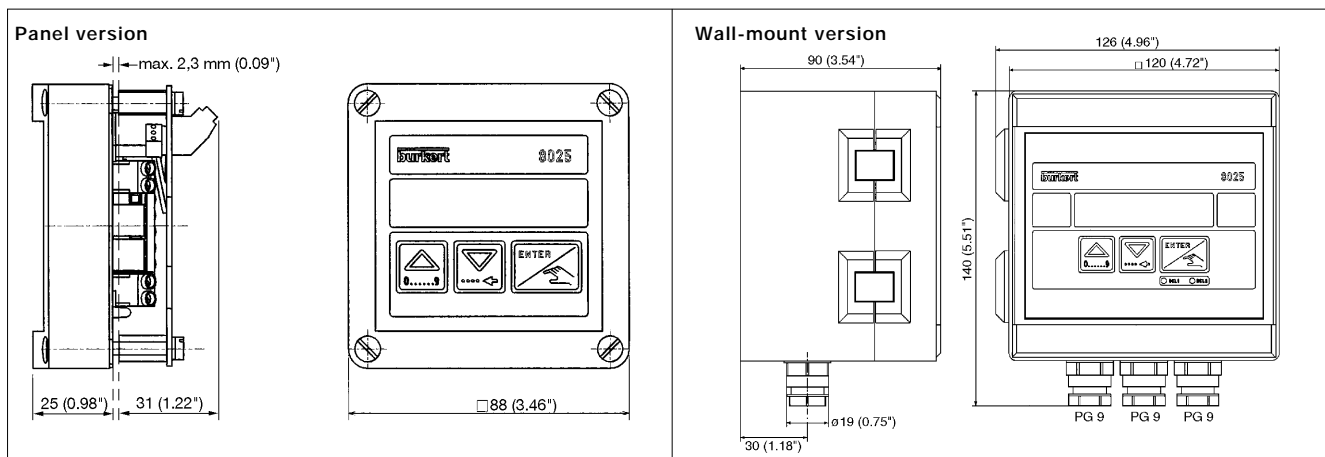

Ordering Chart

A compact Flow Transmitter System type 8035 is consisting of two basic units as to know:

- Fitting type S030 which houses the paddle-wheel,
- Transmitter electronic compact version type SE35

Selection example:

- Fitting type S030 (Brass, G-port connection internal thread, DN 25) 423 982 B
- Transmitter Electronic type SE35 (4...20 mA, pulse output, 2 totalizers, 2 relays, 12...30 VDC) 423 918 J

Ordering Chart Fittings Type S030

Brass body

Specifications	ITEM - NO.					
	DN 15	DN 20	DN 25	DN 32	DN40	DN 50
G-port connection (internal thread)	423 980 M	423 981 A	423 982 B	423 983 C	423 984 D	423 985 E
JIS (ISO 7)-port connection (internal thread)	423 992 D	423 993 E	423 994 F	423 995 G	423 996 H	423 997 A
NPT-port connection (internal thread)	423 986 F	423 987 G	423 988 R	423 989 J	423 990 P	423 991 C
G-port connection (external thread)	423 998 K	423 999 L	424 000 T	424 001 Q	424 002 R ¹⁾	424 003 J ¹⁾

¹⁾ Metric thread

Ordering Chart Transmitter Electronics Compact Type SE35

Specifications	ITEM - NO.		
	Power Supply	Cable Entry	
Flow transmitter with 4...20 mA, pulse output, 2 totalizers	12-30 VDC	DIN 43650 PG9	423 915 F
Flow transmitter with 4...20 mA, pulse output, 2 totalizers	12-30 VDC	1x PG 13.5	423 916 G
Flow transmitter with 4...20 mA, pulse output, 2 totalizers, 2 relays	12-30 VDC	2x PG 13.5	423 918 J
Flow transmitter with 4...20 mA, pulse output on relay reed, 2 totalizers	12-30 VDC	2x PG 13.5	423 919 K
Flow switch with 2 relays	12-30 VDC	2x PG 13.5	423 917 H
Batch controller with 2 totalizers, 1 flow, 2 relays	12-30 VDC	2x PG 13.5	423 920 Q
Stand alone with 2 totalizers, 1 flow	9 VDC batteries	None	423 921 D
Flow transmitter with 4...20 mA, pulse output, 2 totalizers	115-230 VAC	2x PG 13.5	423 922 E
Flow transmitter with 4...20 mA, pulse output, 2 totalizers, 2 relays	115-230 VAC	2x PG 13.5	423 924 G
Flow transmitter with 4...20 mA, pulse output on relay reed, 2 totalizers	115-230 VAC	2x PG 13.5	423 925 H
Flow switch with 2 relays	115-230 VAC	2x PG 13.5	423 923 F
Batch controller with 2 totalizers, 1 flow, 2 relays	115-230 VAC	2x PG 13.5	423 926 A

Ordering separate Flow Transmitter System (panel or wall-mount versions) see next page

In case of special application requirements, please consult for advice.

We reserve the right to make technical changes without notice.
710-GB/ 2-0006

Digital Flow Transmitter

for continuous flow measurement and batch control

Type 8035
Brass-INLINE

Ordering Chart Panel and Wall-mount Versions Type 8025

A Flow Transmitter System in separate version is consisting of three basic units as to know:

- Transmitter Electronic Type 8025 in panel or wall-mount version,
- Flow Sensor Electronic Type SE30,
- Fitting Type S030 which houses the paddle-wheel

Selection example:

-Sep. Transmitter electronic type 8025 (Wall, 4...20 mA, pulse output, 2 totalizers, 2 relays, 12...30 VDC)	418 396 S
-Fitting type S030 (G-port connection internal thread, DN 25)	423 982 B
-Sensor electronic type SE30 (Hall sensor "low power")	423 914 E

Panel version

Specifications	Power Supply	Cable Entry	ITEM - NO.
Flow transmitter with 4...20 mA, pulse output, 2 totalizers	12-30 VDC	None	418 992 Q
Flow transmitter with 4...20 mA, pulse output, 2 totalizers, 2 relays	12-30 VDC	None	418 994 J
Flow transmitter with 4...20 mA, pulse output on relay reed, 2 totalizers	12-30 VDC	None	418 395 Z
Flow switch with 2 relays	12-30 VDC	None	425 492 A
Batch controller with 2 totalizers, 1 flow, 2 relays	12-30 VDC	None	419 536 P

Wall-mount version

Specifications	Power Supply	Cable Entry	ITEM - NO.
Flow transmitter with 4...20 mA, pulse output, 2 totalizers	12-30 VDC	3x PG 9	418 397 T
Flow transmitter with 4...20 mA, pulse output, 2 totalizers, 2 relays	12-30 VDC	3x PG 9	418 396 S
Flow transmitter with 4...20 mA, pulse output on relay reed, 2 totalizers	12-30 VDC	3x PG 9	418 398 C
Flow switch with 2 relays	12-30 VDC	3x PG 9	425 493 B
Batch controller with 2 totalizers, 1 flow, 2 relays	12-30 VDC	3x PG 9	419 539 S
Stand alone with 2 totalizers, 1 flow	9 VDC batteries	1x PG 9	418 402 Z
Flow transmitter with 4...20 mA, pulse output, 2 totalizers	115-230 VAC	3x PG 9	418 400 B
Flow transmitter with 4...20 mA, pulse output, 2 totalizers, 2 relays	115-230 VAC	3x PG 9	418 399 D
Flow transmitter with 4...20 mA, pulse output on relay reed, 2 totalizers	115-230 VAC	3x PG 9	418 401 Y
Flow switch with 2 relays	115-230 VAC	3x PG 9	425 494 C
Batch controller with 2 totalizers, 1 flow, 2 relays	115-230 VAC	3x PG 9	419 542 V

Sensor Electronic for Type SE30 for separate version of 8025

Specifications	Power Supply	Cable Entry	ITEM - NO.
Coil sensor (only connectable to type 8025 wall-mount version with batteries)	None	DIN 43650 PG9	423 912 C
Hall sensor " low power" (only connectable to type 8025, 8021, 8023 and 8034)	from 8025	DIN 43650 PG9	423 914 E

