

DN 15 - DN 50; PN 10



Advantages / Benefits

- ▶ Easy System integration by Easy LINK provides low cost of ownership
- ▶ Can be upgraded to a low cost transmitter providing calibrated pulse output or 4...20 mA
- ▶ Easy mounting and demounting of sensor head by a quarterturn
- ▶ 3-wire Hall version to interface directly with PLC's (both NPN and PNP)
- ▶ Easy to connect: Directly powered from the 8025 panel or 8025 wall
- ▶ Fittings available for all standard hydraulic interfaces

Design

The paddle-wheel flow sensor for continuous flow measurement is specially designed for use in neutral and aggressive, solid-free liquids.

The sensor is made of a compact fitting and an electronic-module quickly and easily connected together by a bayonet.

The Burkert designed plastic-fitting system (PVC, PP, PVDF) ensures simple installation of the sensors into all pipes from DN 15 to DN 50.

The sensor produces a frequency signal proportional to the flow which can easily be transmitted and processed.

- 4...20 mA output signal with transmitter module
- Adjustable frequency output signal with pulse divider module
- Direct connection to batch controller type 8600 mounted on valve
- Connection to separate versions of flow transmitter/indicator type 8025/SE34:
 - Panel version
 - Wall-mount version

Applications

Flow Measurement & Dosing Control

Water treatment and process technology

Cooling water monitoring

Industrial waste water treatment

Auxiliary plants

Irrigation

Ideal system solutions for pure water and chemical aggressive liquids

burkert
Easy Fluid Control Systems

Flow Sensor

for continuous flow measurement

Type 8030
Plastic-INLINE

Design

The flow sensor consists of a transducer (coil or Hall sensor) and an open-cell paddle wheel directly connected to a compact fitting.

In a 2 or 3-wire system, the signal can be displayed or processed directly. The output signal is provided via a 4-pole cable plug according to DIN 43650.

Principle of operation

When liquid flows through the pipe, the paddle-wheel is set in rotation producing a measuring signal in the transducer. The induced voltage is AC. The frequency and amplitude are proportional to the flow.

The flow sensor 8030 with Hall sensor requires an external power of 12...30 VDC.

The flow sensor 8030 with coil requires no external power supply.

The flow sensor 8030 with 4...20 mA output requires an external power of 12...24 VDC.

The flow sensor 8030 with adjustable frequency output requires an external power of 12...30 VDC.

The sensor measures a flow rate from 0.3 m/s (1 ft/s).

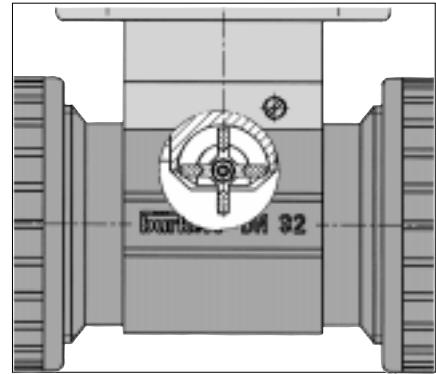

Installation

The flow sensor is made of a compact fitting and an electronic module which can be quickly and easily connected by means of a Quarter Turn.

The recommended In- and Outflow straight pipe length should respect 10xD in and 3xD out.

According to pipe's design, necessary distances can be bigger or use a flow conditioner to obtain the best accuracy. For more informations, please refer to EN ISO 5167-1.

The flow sensor can be installed in either horizontal or vertical pipes.

The suitable pipe size is selected using the diagram on the next page. Pressure and temperature ratings must be respected according to the selected fitting material (see next page).

The flow sensor is not designed for gas flow measurement.

Easy to install

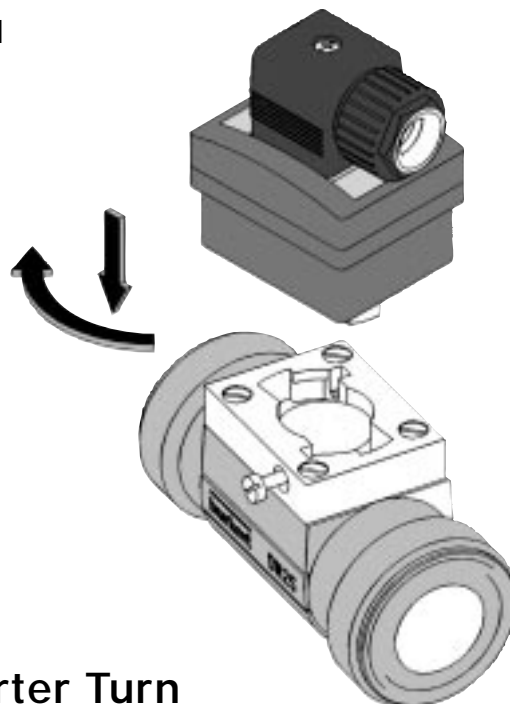

Burkert Quarter Turn

Flow Sensor

for continuous flow measurement

Type 8030
Plastic-INLINE

Examples of fitting selection

The suitable pipe size is selected using the diagram below.

Example 1 :
 Specification of nominal flow: 10 m³/h
 Ideal flow velocity: 2...3 m/s
 For these specifications, the diagram indicates a pipe size of DN 40.

Example 2 :
 Specification of nominal flow: 50 gpm
 Ideal flow velocity: 8 fps
 For these specifications, the diagram indicates a pipe size of 1 1/2".

Pressure-Temperature-Diagram

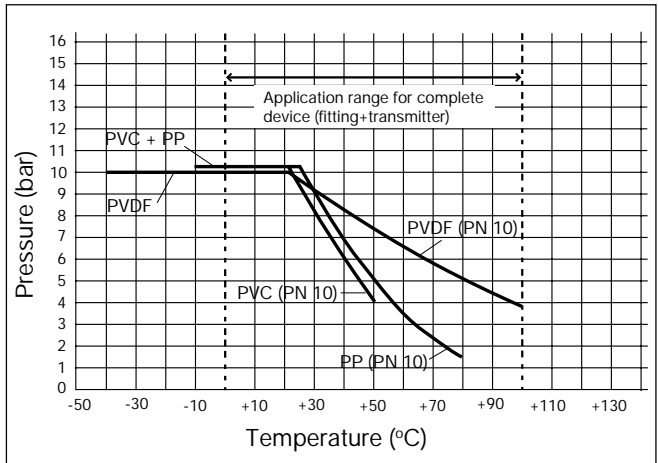
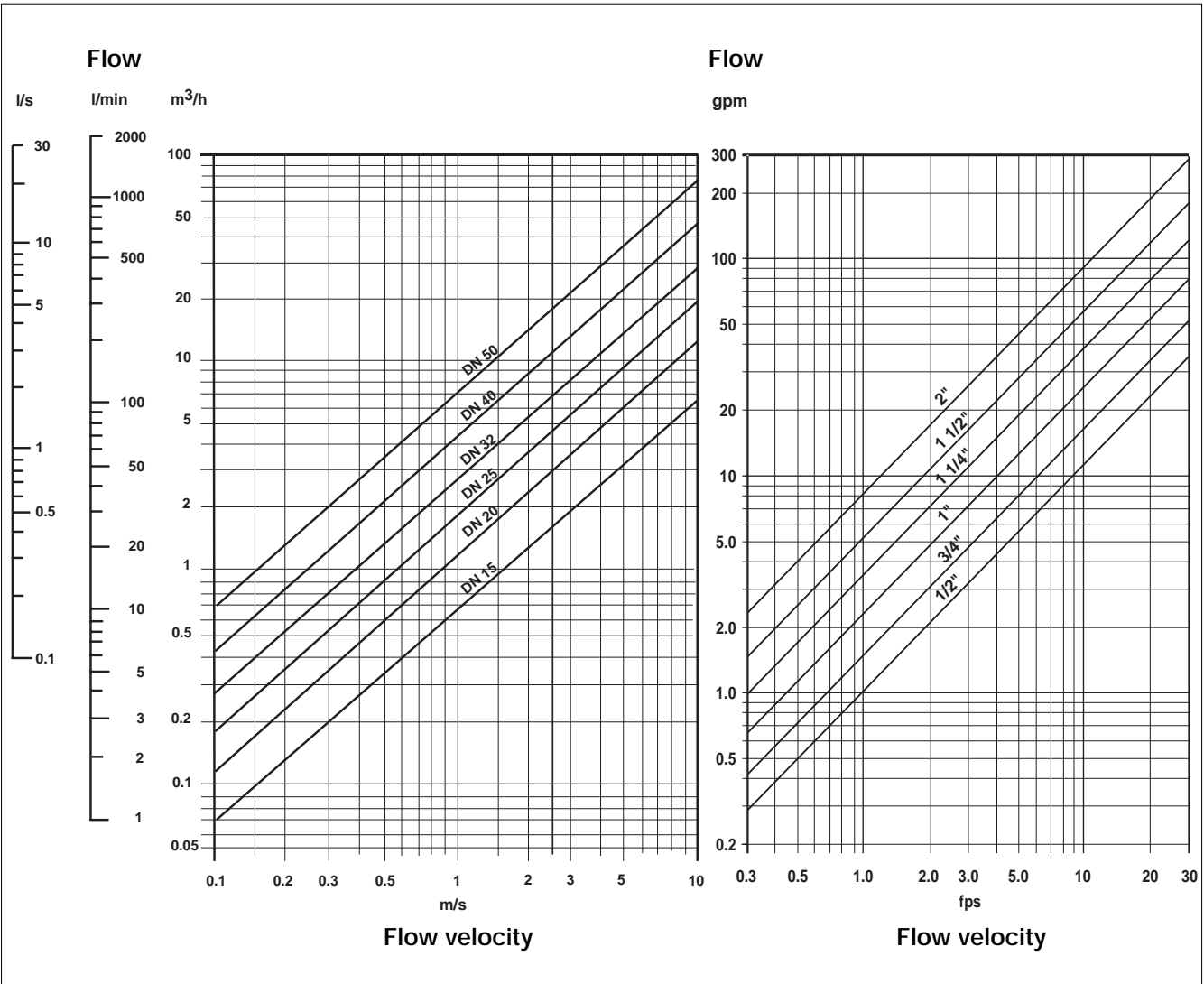

Diagram Flow-Pipe Size-Velocity



Connection to other Burkert devices

8030 with Hall sensor



Batch Controller 8600



Calibrated frequency output module 8021



8030 with Hall sensor
"low power"



8025 / SE34 panel or wall-mount version

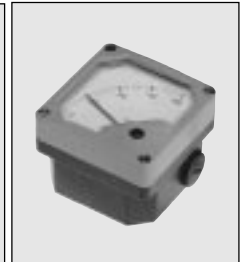

Calibrated frequency output module 8021



4...20 mA output module type 8023



8030 with coil



8025 / SE34 wall-mount with battery power supply



8025



SE34

Flow Sensor

for continuous flow measurement

Type 8030
Plastic-INLINE

Technical data

General data

Pipe diameter from DN 15 to DN 50 (1/2" to 2")
 Measuring range 0.3 m/s to 10 m/s (1.0 fps to 33 fps)
 as from 3 l/min (DN15 pipe, 0,3 m/s flow velocity)
 as from 0.9 gpm (1/2" pipe, 1.0 fps flow velocity)

Measuring error

1. With In-line calibration (Teach-In):
 $\leq \pm 0.5\%$ o.F.S. (at 10 m/s) *
2. With standard mean K-factor:
 $\leq \pm (0.5\%$ o.F.S. + 2.5% o.R.) *

Linearity $\leq \pm 0.5\%$ o.F.S. (at 10 m/s) *
 Repeatability 0.4% o.R. *

Fluid temperature max. PVC: 50°C (122°F); PP: 80°C (176°F);
 PVDF: 100°C (212°F)
 Ambient temperature 0°C to 60°C (32 to 140°F)
 Storage temperature 0°C to 60°C (32 to 140°F)
 Pressure class PN 10

Enclosure IP 65

Fitting PVC, PP, PVDF
 Sensor holder PVC, PP, PVDF
 Paddle-wheel PVDF
 Axis and bearing Ceramic
 O-rings FPM standard
 Housing PC

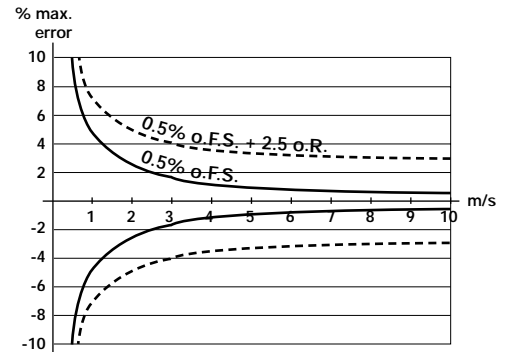

Specific data 8030 with Coil

Cable length 10 m (use shielded cable of max. 1.5 mm² wire cross section)
 (Can only be connected to flow transmitter type 8025/indicator type SE34 with battery power supply in wall-mount version)

Specific data 8030 with Hall Sensor

Supply voltage 12...30 VDC
 Output signal transistor PNP and NPN open collector max. 100 mA
 frequency: 0...200 Hz
 Cable length 50 m (use shielded cable of max. 1.5 mm² wire cross section)

Specific data 8030 with Hall Sensor "low power"

Cable length 10 m (use shielded cable of max. 1.5 mm² wire cross section)
 (Can only be connected to separate versions of flow transmitter type 8025/indicator type SE34 and to 4...20 mA or calibrated frequency output modules)

Specific data 8030 with 4...20 mA Output (8023)

Associated flow sensor Hall sensor "low power"
 Supply voltage 12...24 VDC
 Output signal 4...20 mA
 Load max. 500Ω at 12 V
 max. 1000Ω at 24 V
 Accuracy $\leq 2\%$
 Material of additional housing PA

Specific data 8030 with Calibrated Frequency Output (8021)

Associated flow sensor Hall sensors
 Supply voltage 12...30 VDC
 Output signal transistor PNP and NPN open collector max. 100 mA
 Accuracy 0,1%
 Material of additional housing PA

* Under reference conditions, i.e. measuring fluid = water, ambient and water temperature = 20 °C, applying the minimum inlet and outlet pipe straights, matched inside pipe dimensions
 o.R. = of reading
 o.F.S. = of full scale (10 m/s)

Operation and display

Type 8023 with 4...20 mA output module

The operation is specified according to two levels:

- ▶ **Indication in operating mode**
 - Flow (digits and bargraph)
- ▶ **Parameter definition**
 - K-factor
 - Time unit
 - 4...20 mA measuring range

The device works without the control unit. The control unit enables only to perform parameter definition.

4 ... 20 mA module with control unit (1077)



Type 8021 with calibrated frequency output module

The operation is specified according to the following level:

- ▶ **Parameter definition**
 - K-factor
 - Multiplier D

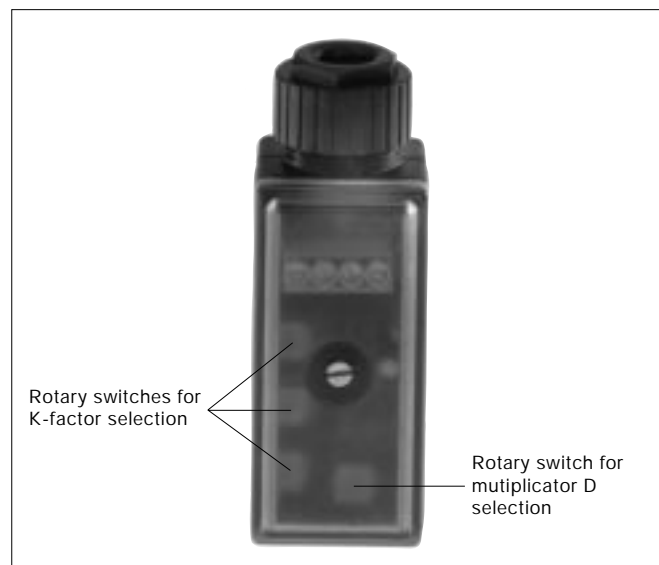

Flow Sensor

for continuous flow measurement

Type 8030

Plastic-INLINE

Dimensions [mm (inch)]

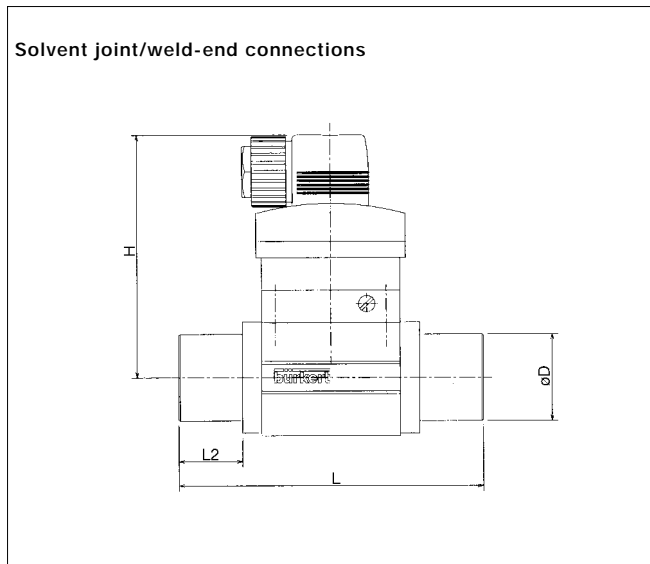
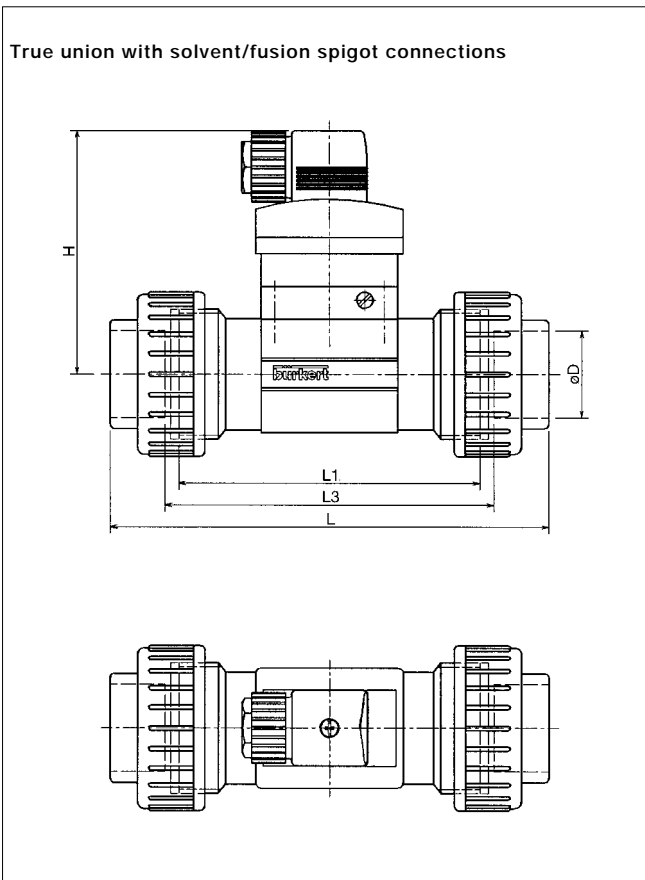

Dimensions [mm] True union ISO (PVC/PP/PVDF)

Port connection	DN	Variable dimensions [mm]				
		Ø D	L	L1	L3	H
True union	15	20	128	90	96	92
connection with	20	25	144	100	106	89
solvent/ fusion	25	32	160	110	116	89,5
spigot	32	40	168	110	116	93
	40	50	188	120	127	97
	50	63	212	130	136	104

Dimensions [inch] True union ASTM (PVC)

Port connection	DN [mm(inch)]	Variable dimensions [inch]				
		Ø D	L	L1	L3	H
True union	15 (9/16)	.79	5.04	3.55	3.78	3.62
connection with	20 (3/4)	.99	5.67	3.94	4.18	3.51
solvent/ fusion	25 (1)	1.26	6.30	4.33	4.57	3.52
spigot	32 (1 1/4)	1.58	6.62	4.33	4.57	3.66
	40 (1 1/2)	1.97	7.41	4.73	5.00	3.82
	50 (2)	2.48	8.35	5.12	5.36	4.10

Dimensions [mm] True union JIS (PVC)

Port connection	DN	Variable dimensions [mm]				
		Ø D	L	L1	L3	H
True union	15	18.40	135	90	96	92
connection with	20	26.45	151	100	106	89
solvent/ fusion	25	32.55	167	110	116	89,5
spigot	32	38.60	175	110	116	93
	40	48.70	196	120	127	97
	50	60.80	219	130	136	104

Dimensions [mm]

Port connection	DN	Variable dimensions [mm]					
		ØD	L		L2		H
			PVC	PP PVDF	PVC	PP PVDF	
Solvent joint or	15	20	90	85	16,5	14	92
weld-end	20	25	100	92	20	16	89
connection	25	32	110	95	23	18	89,5
	32	40	110	100	27,5	20	93
	40	50	120	106	30	23	97
	50	63	130	110	37	27	104

Dimensions [inch]

Port connection	DN [mm (inch)]	Variable dimensions [inch]					
		ØD	L		L2		H
			PVC	PP PVDF	PVC	PP PVDF	
Solvent joint or	15 (9/16)	.79	3.54	3.35	.65	.55	3.62
weld-end	20 (3/4)	.99	3.94	3.62	.79	.63	3.51
connection	25 (1)	1.26	4.33	3.74	.91	.71	3.52
	32 (1 1/4)	1.58	4.33	3.94	1.08	.79	3.66
	40 (1 1/2)	1.97	4.72	4.17	1.18	.91	3.82
	50 (2)	2.48	5.12	4.33	1.46	1.06	4.10

Flow Sensor

for continuous flow measurement

Type 8030
Plastic-INLINE

Ordering Chart

A complete Flow Sensor System type 8030 is consisting of two or three basic units as to know:

- Fitting type S030 which houses the paddle-wheel,
- Sensor Electronic type SE30,
- Upgradable to a low-cost transmitter with calibrated pulse output (8021/1077) or 4...20 mA output (8023)

This Flow Sensor can also be connected to a transmitter type 8025 in panel- or wall-mount version (see data sheet of type 8025 flow transmitter).

Selection example: A Flow Sensor System with 4...20 mA output for PVC pipe DN25 consists of:

-Fitting type S030 (True union with solvent spigot)	423 940 U
-Sensor Electronic type SE30 (Hall sensor "low power")	423 914 E
-4...20 mA output module type 8023	130 428 V
-Control unit for 4...20 mA output module type 1077-3	130 446 X

Ordering Chart Fittings Type S030

PVC body

Specifications	ITEM - NO.					
	DN 15	DN 20	DN 25	DN 32	DN40	DN 50
True union connection with solvent spigot (International standard version)	423 938 N	423 939 P	423 940 U	423 941 R	423 942 J	423 943 K
True union connection with solvent spigot (North America standard version)	423 950 W	423 951 K	423 952 L	423 953M	423 954 N	423 955 P
True union connection with solvent spigot (JIS)	429 072 T	429 073 U	429 074 V	429 075 W	429 076 X	429 077 Y
Solvent joint connection	423 944 L	423 945 M	423 946 N	423 947 P	423 948 Y	423 949 Z

PP body

Specifications	ITEM - NO.					
	DN 15	DN 20	DN 25	DN 32	DN40	DN 50
True union connection with fusion spigot	423 956 Q	423 957 R	423 958 S	423 959 T	423 960 Y	423 961 M
Weld-end connection	423 962 N	423 963 P	423 964 Q	423 965 R	423 966 J	423 967 K

PVDF body

Specifications	ITEM - NO.					
	DN 15	DN 20	DN 25	DN 32	DN40	DN 50
True union connection with fusion spigot	423 968 U	423 969 V	423 970 S	423 971 P	423 972 Q	423 973 R
Weld-end connection	423 974 J	423 975 K	423 976 L	423 977 M	423 978 W	423 979 X

Ordering Chart Sensor Electronics Type SE30

Specifications	Power Supply	Cable Entry	ITEM - NO.
Coil Sensor (only connectable to type 8025/SE34 wall-mount version with batteries)	None	DIN 43650 PG9	423 912 C
Hall Sensor	12-30 VDC	DIN 43650 PG9	423 913 D
Hall Sensor "low power" (only connectable to types 8025, 8021, 8023 and SE34)	from 8025/8023	DIN 43650 PG9	423 914 E

Ordering Chart for Standard Output Signals

Specifications	Power Supply	Cable Entry	ITEM - NO.
Calibrated pulse output module type 8021	12-30 VDC	1x PG9	418 895 P
4...20 mA output module type 8023	12-24 VDC	1x PG9	130 428 V
Control unit for 4...20 mA output module type 1077-3	12-24 VDC	None	130 446 X

In case of special application requirements, please consult for advice.

We reserve the right to make technical changes without notice.
802-GB/ 2-0005