

**3/2-Way; G<sup>1/8</sup>-M5; 0-10 bar**



**Advantages/Benefits**

- ▶ Coil can be changed easily with valve in place
- ▶ Coil can be locked in 4x 90° positions or move freely between, as required
- ▶ Medium is only in contact with the valve internals and body
- ▶ High-quality seal material FPM (Viton) standard
- ▶ Wide range of cable plug options Type 2506
- ▶ Compact design

**Design/Functions**

The valves are based on a modular concept comprising three basic elements; Valve assembly, push-over coil and standard cable plug. The valve assembly consists of a body to which the armature guide tube containing the plunger, seals and springs is attached. The coil is pushed over the guide tube and thus isolated from the medium. The medium is only in contact with the valve internals and body.

A wide selection of pipe and orifice sizes is offered. Valves are available in brass or stainless steel. All valves have high-quality viton (FPM) seals as standard.

To simplify ordering, a wide selection of standard combinations of valve body, push-over coil and standard cable plug can be ordered with one order number.

Cable plug options of Type 2506 are available to suit special electrical application requirements.

- The modular concept provides flexibility to meet application requirements.
- The valve is interchangeable with Type 300.

**Applications**

**Fluids**

Brass version: Neutral gases and liquids, e.g.compressed air, town gas, natural gas, water, hydraulic oil, petrol.  
Stainless steel version: Difficult and slightly aggressive media

Suitable for technical vacuum

**Applications**

- Pneumatic control
- Shut-off, dosing, filling and ventilating
- Small-scale instruments, laboratory and measuring technology
- Welding technology



### Technical Data Type 6012

#### Circuit function

**C** 3/2-way valve,  
when de-energized, outlet A  
pressure relieved

#### Symbol

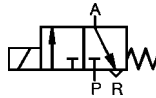

**D** 3/2-way valve,  
when de-energized, outlet B  
pressurized

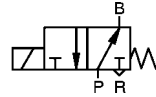

#### Circuit function

**T** Universal mixer or distributor valve,  
when de-energized R ↔ A open  
and P ↔ A closed,  
for universal use  
(on request)

#### Symbol

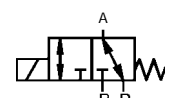

#### Operating Data (Valve)

Pressure range	0-10 bar (see specifications)
Port connection	Threaded port G 1/8" - M5
Orifice	DN 1.2-1,6 mm
Fluid	Neutral gases and liquids, e.g. compressed air, town gas, natural gas, water, hydraulic oil, petrol. Stainless steel version: Difficult and slightly aggressive media. Suitable for techn. vacuum.
Medium temperature	-10 to +100 °C
Max. ambient temperature	+55 °C
Max. viscosity	21 mm <sup>2</sup> /s
Response times	
opening	12 ms
closing	8 ms
Installation	as required, but preferably with solenoid system upright

#### Operating Data (Actuator)

Operating voltages	AC 24, 110, 230 V/50 Hz, DC 24V/=						
Voltage tolerance	±10 %						
Power consumption	<table border="1"> <tr> <th>AC inrush</th> <th>AC hold</th> <th>DC</th> </tr> <tr> <td>9 VA</td> <td>6 VA/4 W</td> <td>4 W</td> </tr> </table>	AC inrush	AC hold	DC	9 VA	6 VA/4 W	4 W
AC inrush	AC hold	DC					
9 VA	6 VA/4 W	4 W					
Duty cycle	100% continuously rated						
Duty cycle for multiple manifolds	60% for manifold mounting (30 min) or use 2W-version (on request)						
Cycling rate	up to 1 000 c.p.m.						
Protection class with cable plug	IP 65						
Electr. connection	Delivery standard: Cable plug DIN 43 650 C, 0-250 V(other versions see accessories)						

#### Materials

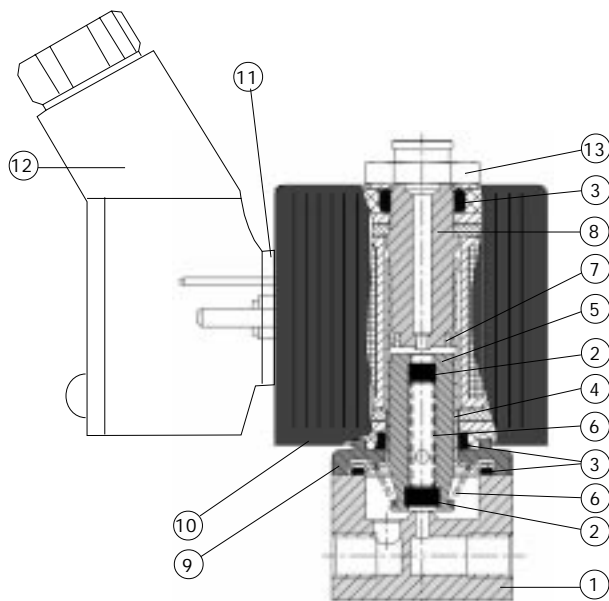

1 Valve body:	Brass, S.Steel 1.4305 (G1/8")
2 Plunger-seal:	FPM (Viton)
3 O-rings:	FPM (Viton)
4 Armature guide tube:	1.4303
5 Plunger:	1.4105
6 Spring:	1.4310
7 Shading ring:	Cu (brass version) Ag (stainless steel version)
8 Stopper:	1.4105
9 Flange:	Zn3 gl cC (surface)
10 Coil:	PA (Polyamide)
11 Flat seal:	NBR
12 Cable plug:	PA (Polyamide)
13 Locknut:	9SMnPb28K (surface Zn5glcA)

### Specifications - Ordering Chart (Other Versions on Request)

#### Brass body; Viton seal

(with standard-cable plug 0-250 V AC/DC)

Circuit function <sup>1)</sup>	Orifice [mm]	Kv-value water <sup>2)</sup> [m <sup>3</sup> /h]	Pressure range <sup>3)</sup> [bar]	Port connection	Voltage/frequency [V/Hz]	Weight [g]	Order-No. (without manual override)	Order-No. (with manual override)
C	1,2	0,045	0-10	M5	24/=	109	134 143 P	-
					24/50		134 144 Q	-
					110/50		134 145 R	-
					230/50		134 146 J	-
C	1,2	0,045	0-10	G 1/8	24/=	131	134 151 P	134 159 X
					24/50		134 152 Q	134 160 U
					110/50		134 153 R	134 161 R
					230/50		134 154 J	134 162 J
C	1,6	0,06	0- 6	M5	24/=	109	134 147 K	-
					24/50		134 148 U	-
					110/50		134 149 V	-
					230/50		134 150 S	-
C	1,6	0,06	0- 6	G 1/8	24/=	131	134 155 K	134 163 K
					24/50		134 156 L	134 164 L
					110/50		134 157 M	134 165 M
					230/50		134 158 W	134 166 N
D	1,2	0,045	0-10	M5	24/=	109	134 199 Q	-
					24/50		134 200 D	-
					110/50		134 201 S	-
					230/50		134 202 T	-
D	1,2	0,045	0-10	G 1/8	24/=	131	134 208 H	-
					24/50		134 209 A	-
					110/50		134 210 W	-
					230/50		134 211 K	-
D	1,6	0,06	0- 6	M5	24/=	109	134 204 V	-
					24/50		134 205 W	-
					110/50		134 206 X	-
					230/50		134 207 Y	-
D	1,6	0,06	0- 6	G 1/8	24/=	131	134 212 L	-
					24/50		134 213 M	-
					110/50		134 214 N	-
					230/50		134 215 P	-

#### Stainless steel body; Viton seal

(with standard-cable plug 0-250 V AC/DC)

Circuit function <sup>1)</sup>	Orifice [mm]	Kv-value water <sup>2)</sup> [m <sup>3</sup> /h]	Pressure range <sup>3)</sup> [bar]	Port connection	Voltage/frequency [V/Hz]	Weight [g]	Order-No. (without manual override)	Order-No. (with manual override)
C	1,2	0,045	0-10	G 1/8	24/=	127	134 167 P	-
					24/50		134 168 Y	-
					110/50		134 169 Z	-
					230/50		134 170 W	-
C	1,6	0,06	0- 6	G 1/8	24/=	127	134 171 K	-
					24/50		134 172 L	-
					110/50		134 173 M	-
					230/50		134 174 N	-
D	1,2	0,045	0-10	G 1/8	24/=	127	134 216 Q	-
					24/50		134 217 R	-
					110/50		134 218 S	-
					230/50		134 219 T	-
D	1,6	0,06	0- 6	G 1/8	24/=	127	134 220 Y	-
					24/50		134 221 M	-
					110/50		134 222 N	-
					230/50		134 223 P	-

<sup>1)</sup> To use valves in other operations than specified, will change the specified maximum pressure range. Special applications on request.

<sup>2)</sup> Measured with 6 bar upstream pressure and 1 bar pressure drop across the valve at +20 °C.

<sup>3)</sup> All pressures quoted are gauge pressures with respect to the prevailing atmospheric pressure.

### Dimensions (in mm)

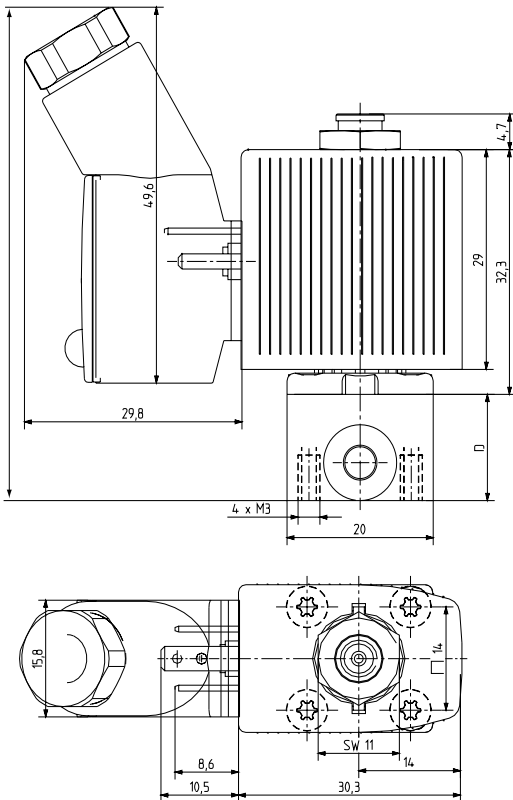

View without cable plug

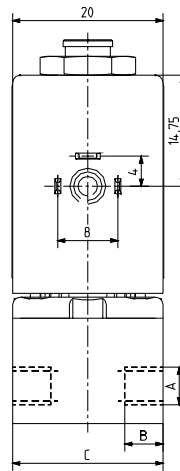

### Variable Dimensions

	Armature			
	A	B	C	D
Threaded Port G without manual override	1/8	8	25	19,5
Threaded Port G with manual override	1/8	8	25	19,5
Threaded Port M5 without manual override	M5	5	20	14,0
Threaded Port M5 with manual override	M5	5	20	14,0

### Cable plug to DIN 43650, Form C

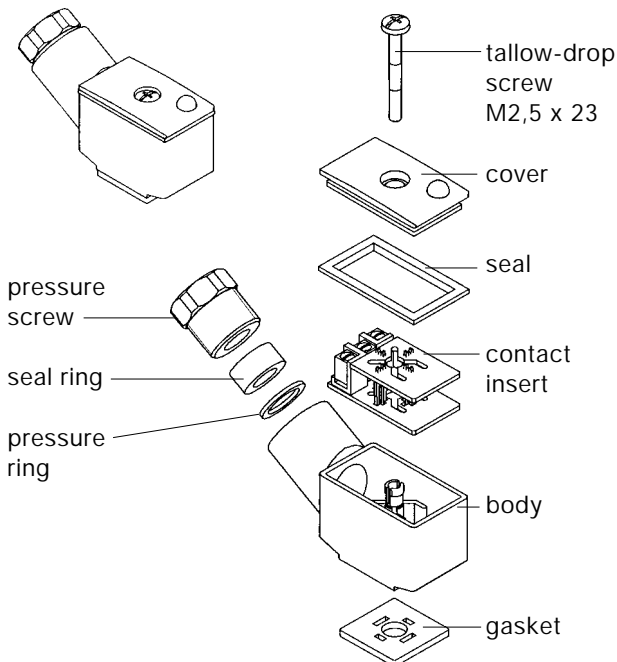

### Ordering Chart for Accessories

Device/ Accessory	Features	Order-No.
<b>Cable-plugs<sup>1)</sup></b> Type 2506	Standard cable plug, 0-250 V AC/DC (standard-delivery) <sup>1)</sup>	008 353 P
	with LED, 12-24 V AC/DC	008 402 A
	with LED, 100-120 V AC/DC	008 403 B
	with LED, 200-240 V AC/DC	008 404 C
	with LED + varistor, 12-24 V AC/DC	008 408 Q
	with LED + varistor, 100-120 V AC/DC	008 409 R
	with LED + varistor, 200-240 V AC/DC (optional wirings and connection specifications see data sheet Type 2506)	008 410 D

<sup>1)</sup> The standard cable plug (0-250 V AC/DC), Order-No. 008 353 P is part of the standard delivery. Ordering of optional cable plugs with separate ordering number.

A wide selection of further cable plugs is available (see special data sheet Type 2506)