

3/2 and 4/2 multi-way valves; servo-assisted;
DN 4; flow rate: 300 l/min.; module flange port connections



Advantages / Benefits

- ▶ Optimal system solutions due to high level of modularity
- ▶ High flow rate at compact design
- ▶ Long service life even with non-lube conditions
- ▶ With manual override
- ▶ Extendable due to module flange
- ▶ Various options for the service ports 2 and 4
- ▶ High switch reliability
- ▶ Wide range of cable plugs with circuitry as accessories
- ▶ Low weight

Design/Function

Type 5470 feature high switch reliability diaphragm seat valves as 3/2 and 4/2 way version. The valve consists of three modules, valve body with servo-diaphragm, plungers and seat seal as well as numerous connection possibilities for the service ports 2 and 4.

The body and valve internal parts are made of high quality thermoplastic, the return spring is made of Stainless Steel.

A 16 mm rocker solenoid valve type 6106 with rectifier is used as pilot.

Tag connectors are used as electrical contact (acc. DIN 43 650 Form C) with the cable plug type 2506.

The extendable type 5470 with module flange can be used as block modules (tag connectors on top) with a coil spacing of 18 mm.

Applications

Fluids

Lubricated and unlubricated air, neutral gases

Applications

Control valves (single valves, valve blocks) for pneumatic linear and rotary actuators (actuator systems) preferably for

- Food and beverage industry
- General processing industry
- Packing machine manufacturers.
- Textile industry
- Machine tool manufacturers
- Wood working machine manufacturers

bürkert
Easy Fluid Control Systems

Technical data type 5470

Circuit functions

C 3/2 way valve,
when de-energized,
outlet port exhausted

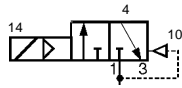

G 4/2 way valve
when de-energized,
pressure inlet port 1 connected
to outlet port 2,
outlet port 4 exhausted

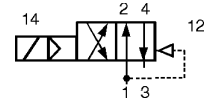

D 3/2 way valve,
when de-energized,
port 2 pressurized

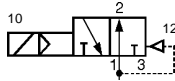

Specifications

Circuit function	Orifice [mm]	Flow rate ¹⁾ Q _{Nn} -value air [l/min]	Pressure range ²⁾ [bar]	Service port connections
C (3/2)	4,0	300	2 - 10	Plug-in coupling legris ø 6 mm downwards with flow restrictor
D (3/2)	4,0	300	2 - 10	Plug-in coupling legris ø 6 mm downwards with flow restrictor
G (4/2)	4,0	300	2 - 10	Plug-in coupling / screwed tube - / threaded port G 1/8

¹⁾ Measured with 6 bar upstream pressure and 1 bar pressure drop across the valve and at +20 °C.

²⁾ All pressures quoted are gauge pressures with respect to the prevailing atmospheric pressure.

Valve specifications

Body material	PA (Polyamide)
Valve internal parts	PA
Return spring	Stainless Steel
Seal material	NBR
Fluids	Lubricated, unlubricated compressed air, neutral gases
Media temperature	-10 up to +50 °C
Ambient temperature	-10 up to +55 °C
Response times ³⁾	2 and 3 W coil
Open (On)	15 ms
Close (Off) (without electronics)	12 ms
Close (Off) (with electronics) ⁴⁾	20 ms
Port connections	
Connection 1 and 3	Module flange
Connection 2 and 4	<ul style="list-style-type: none"> • G 1/8 in front • Plug-in coupling Ø 6 mm below or in front • Screwed tube connector SL 6/4 mm, in front

Solenoid specifications

Operating voltage	24 V DC 110-120 V DC 220-240 V DC (for alternating current cable plug type 2506 with rectifier necessary) ⁴⁾
Voltage tolerance	±10 %
Electr. power consumption	2 W and 3 W
Duty cycle	100 % continuously rated
Electr. connection	tag connectors on top acc. DIN 43650, Form C, for cable plugs Type 2506 (see accessories)
Rating	IP 65 (with cable plug)
Ex-approval	(see data sheet Ex-versions)

Installation

- Preferably on valve blocks

Mounting position: any, preferably solenoid system upright

³⁾ Measured at connection 2; time from electrical switching to pressure increase to 90 % (opening) or pressure drop to 10 % (closing) of operational pressure of 6 bar.

The valves given apply for DC and AC.

⁴⁾ When using electronics (diodes for controlling LEDs or for rectifying), the closing time is delayed 8 up to 10 ms.

Dimensions [mm]

Valve and assembly (DIN-rail installation)

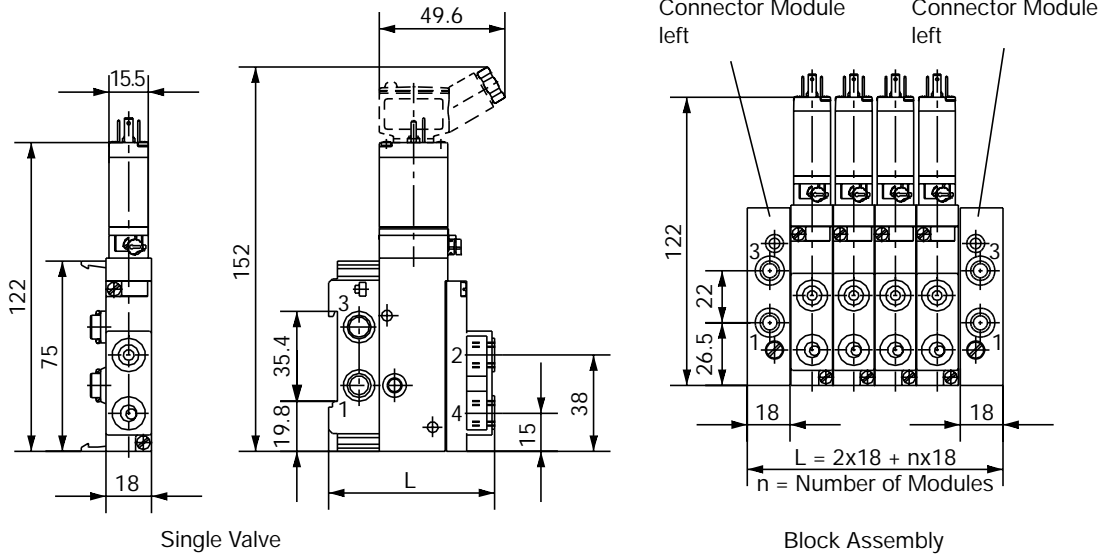

Service port connections

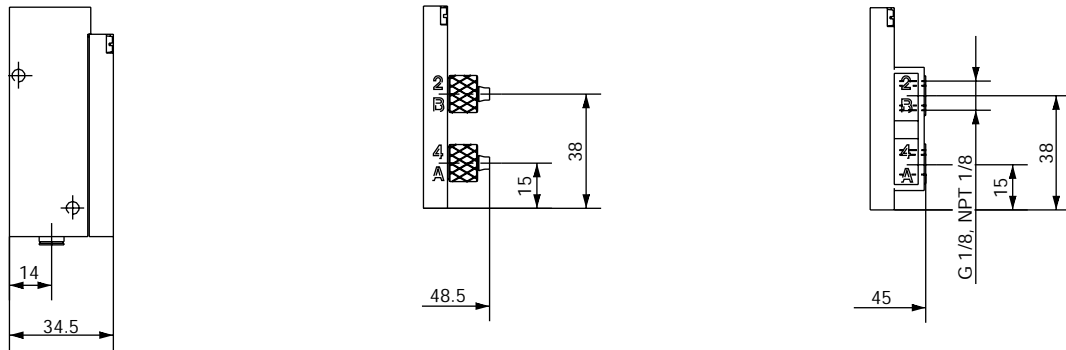

Version 1 Circuit function C, plug-in coupling legris \varnothing 6 mm downwards

Version 2 Screwed tube connector SL 6/4 mm in front

Version 3 Threaded port G 1/8 in front

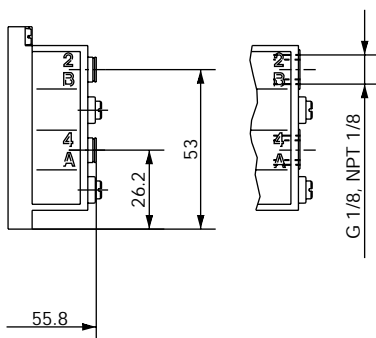

Version 4 Plug-in coupling legris \varnothing 6 mm or threaded port G 1/8 (NPT 1/8 on request) in front, with one-way flow restrictor

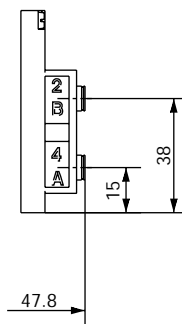

Version 5 Plug-in coupling legris \varnothing 6 mm in front

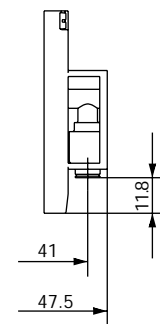

Version 6 Circuit function D and G, plug-in coupling legris \varnothing 6 mm in front, downwards

Ordering chart connection modules for valve blocks and accessories

Modules	Port connection	Item No.
Connector module left	G 1/8	623 753 C
	G 1/4	623 758 R
	Plug-in coupling ø 8 mm	623 755 E
	Plug-in coupling ø 10 mm	623 762 D
Connector module right	G 1/8	623 767 A
	G 1/4	623 773 G
	Plug-in coupling ø 8 mm	623 770 R
	Plug-in coupling ø 10 mm	623 784 U
Intermediate supply module	G 1/8	627 742 D
	G 1/4	631 288 B
	Plug-in coupling ø 8 mm	631 287 S
	Plug-in coupling ø 10 mm	631 290 H

Ordering chart additional accessories

Accessory part	Item No.
Extendable 3-station cable plug type 1057-SA, IP20, with looped through neutral line and earth (only 24VDC)	629 253 M
Earth and neutral line cable set	629 262 N
Control line with AMP-plug 540 mm	629 181 W
Standard rail 300 mm for block 8 - 12 station with intermediate supply or block 8 - 14 station without intermediate supply	640 789 W
Standard rail 480 mm for block 13 - 17 station with intermediate supply or block 15 - 19 station without intermediate supply	640 788 V
Standard rail 498 mm for block 17 - 22 station with 2 intermediate supplies or for block 18 - 23 station with 1 intermediate supply	630 579 R
Blanking plug for plug-in coupling ø 6 mm	015 397 J
Blanking plug for plug-in coupling ø 8 mm	900 065 H
Blanking plug for plug-in coupling ø 10 mm	015 400 S
Pressure rings for plug-in coupling ø 6 mm	015 401 P
Pressure rings for plug-in coupling ø 8 mm	015 402 Q
Pressure rings for plug-in coupling ø 10 mm	015 403 R
Blanking screw for screwed port connection G 1/8	631 019 Y
Blanking screw for screwed port connection G 1/4	631 020 V
Blanking plug for screwed tube connector 6/4	005 390 E
Covering plate for vacant valve spaces	623 827 P
Basic module with covering plate	700 446 K
Indicating tags	623 816 L

Ordering chart accessories / cable plugs

Accessory part	Characteristics	Item No.
Cable plug type 2506 1)	without circuit, 0 - 250 V	008 353 P
Cable plug type 2506 1)	with LED, 12 - 24 V	008 402 A
Cable plug type 2506 1)	with LED and varistor, 12 - 24 V	008 408 Q
Cable plug type 2506 1)	with LED, rectifier and varistor, 12 - 24 V	008 354 Q
Cable plug type 2506 1)	with LED, rectifier and varistor, 200 - 240 V	008 356 J

¹⁾ With these accessories, only a minimum of possible cable plugs with circuit are being mentioned. For other versions see data sheet type 2506.
A flat seal and a fixing screw are part of the delivery scope of a cable plug.

Ordering chart valves type 5470 Extendable module valve (other versions on request)

Scope of delivery: All valves with manual override and with NBR seal;
without cable plug (see accessories)

Electr. connection: On top

Expandable module valves; without cable plug

Circuit function	Orifice [mm]	Flow rate Q _{Nn} value air [l/min]	Supply port connection 1 and 3	Service port connection 2 and 4	Pressure range [bar]	Voltage / frequency [V/Hz]	Electrical power consumption [W]	Item No.
C with flow restrictor	4,0	300	Module flange pattern	Plug-in coupling legris ø 6 mm downwards Version 1	2 - 10	24/DC	2	136 872 L
						110-120/DC	3	136 873 M
						220-240/DC	3	136 874 N
D	4,0	300	Module flange pattern	Plug-in coupling legris ø 6 mm downwards Version 6	2 - 10	24/DC	2	136 875 P
						110-120/DC	3	136 876 Q
						220-240/DC	3	136 877 R
G with flow restrictor	4,0	300	Module flange pattern	Screwed tube connector SL 6/4 mm in front Version 2	2 - 10	24/DC	2	136 878 S
						110-120/DC	3	136 879 T
						220-240/DC	3	136 880 R
				Threaded port G 1/8 in front Version 3	2 - 10	24/DC	2	136 881 E
						110-120/DC	3	136 882 F
						220-240/DC	3	136 883 G
				Threaded port G 1/8 with one-way flow restrictor Version 4	2 - 10	24/DC	2	136 884 H
						110-120/DC	3	136 885 A
						220-240/DC	3	136 886 B
				Plug-in coupling legris ø 6 mm in front Version 5	2 - 10	24/DC	2	136 887 C
						110-120/DC	3	136 888 M
						220-240/DC	3	136 889 N
Plug-in coupling legris ø 6 mm downwards Version 6	2 - 10	24/DC	2	136 890 K				
		110-120/DC	3	136 891 G				
		220-240/DC	3	136 892 H				

Exploded view of block-mounting with extendable valves on DIN EN rail 50022 (see accessories)

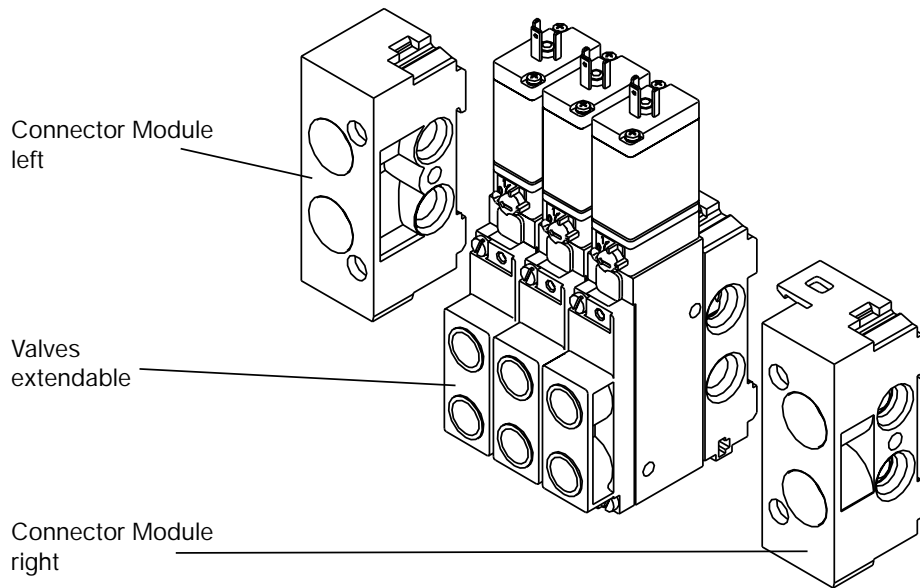

Dimensions [mm] Cable plug type 2506

Cable plug type

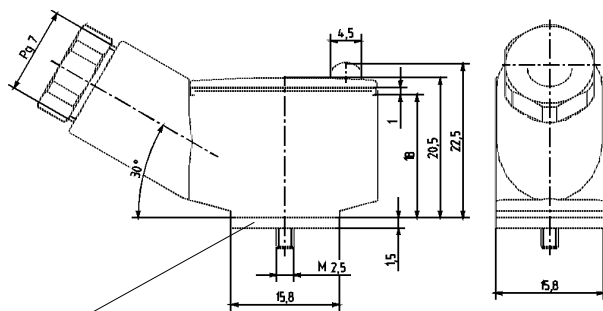

Flat seal

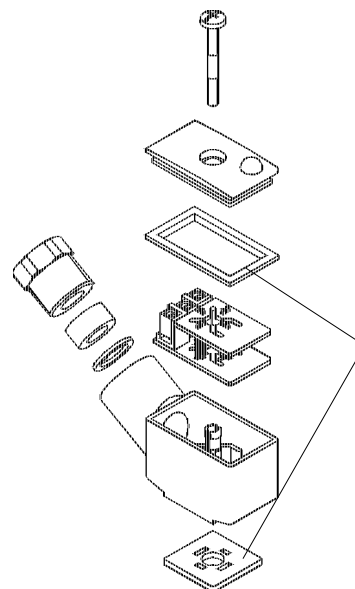
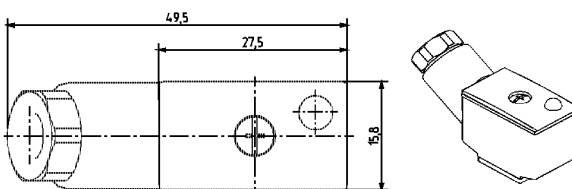

Attention!
Pay attention to a correct fit of the flat seal when mounting the cable plug!

Cable plug type 2506 (pin assignment acc. DIN 43650, Form C)