

Stainless Steel, DN15 - DN50 mm, PN16



Advantages / Benefits

- ▶ Ultra compact design
 - Low weight
- ▶ Automatic self-adjustment of basic parameters by finger tip control
- ▶ Integrated, cascaded process controller with parameter definable PID-algorithm
- ▶ User-friendly operation
 - LCD and key pad
 - Clear menu-guided control
 - Code-protection against unauthorized access
- ▶ High operating safety
 - Maintenance-free packing glands
- ▶ **CE** certified

Design

Type 2632 is a control valve with an electropneumatically operated positioner which offers the main functional groups position sensor, electropneumatic control system and micro-processor controlled electronics.

The position sensor which, depending on the specific coupling, is located in or outside of the positioner, measures the actual regulating distance of the continuous valve.

The micro-processor controlled electronics continuously compares this actual value to a controller output, pre-defined by the standard signalinput. In case of a control difference, the electro-pneumatic control system corrects the control position. Due to the 4...20 mA standard transmitter input the positioner can also be used as a cascaded process controller for controlled variables such as flow, temperature, pressure, level etc.

- Programmable flow curves:
 - linear, equal percentage
 - freely programmable via restart points
- No control air consumption in stabilized condition
- Common exhaust via G1/8 port connection
- Pipe free coupling to Bürkert position control valves
- Various connection options to stroke and part-turn valve actuators
- Excellent flow characteristic combined with high flow rates

Applications

Positioning of pneumatically operated continuous valves

- Textile dyeing and bleaching
- Food processing
- Chemical process engineering
- Water treatment
- Medical technology (Sterilizers)
- Mechanical engineering

bürkert
Easy Fluid Control Systems

Technical Data Positioner Type 1067

Electrical Data

Voltage supply:	24 V DC
Power consumption:	< 10 W
Signal input for positioner:	Unit signal: 4 ... 20 mA 0 ... 20 mA 0 ... 10 V
Binary input:	Configurable as normally open or closed contact.
Connection:	Clamping screw 1,5 mm Cable gland 2 x PG 9

Pneumatic Data

Instrument air:	Air, filtered compressed air, lubricated or non-lubricated
Pressure range:	0 ... 6 bar
Air performance	
Air inlet valve:	33 (66) NI/min ⁽¹⁾
Exhaust valve:	38 (76) NI/min ⁽¹⁾
	⁽¹⁾ In case of pressure drop from 6 to 5 bar. (Figures in brackets as option).
Internal air consumption in leveled status:	0 NI/min
Connection:	Internal screw thread G 1/8''

Installation and Operation Data

Overall dimensions of positioner	(B x H x T): 125 mm x 80 mm x 77 mm
Body material:	Aluminium, laquered
Fluid plate material:	Aluminium, anodized
Weight of positioner:	approx. 1 kg
Rating:	IP 65
Operating temperature:	0 ... 60 °C

Functional Diagram

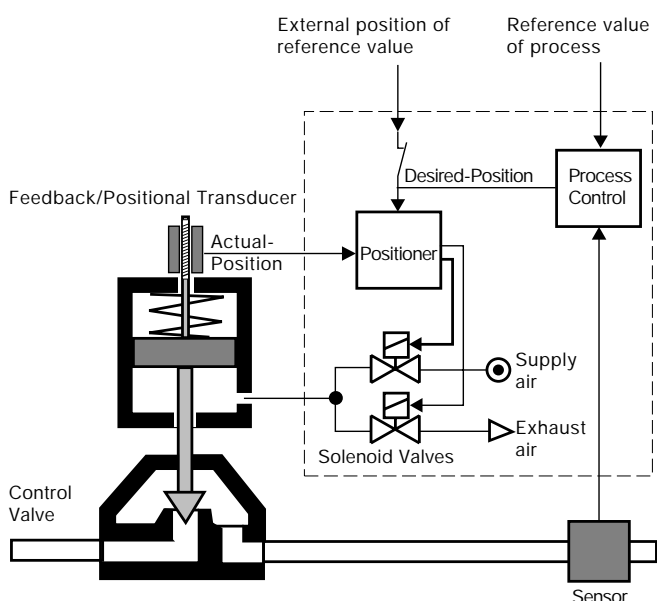

Technical Data Control Valve 2632

Valve

Size (DN):	15, 20, 25, 32, 40, 50
Rangeability:	Control range $\geq 50:1$
Flow features:	Modified equal percentage
Flow capacity:	see table page 4
Medium temperature:	-10°C...+180°C
Max. Operating pressure:	16 bar (at ambient temperature)

Actuator

Actuator size (ø mm):	see table page 3
Signal (bar):	Air min. 5.5 bar, air max. 7 bar
Function:	Normally closed under spring force. Flow-direction under seat.

Tightness

According to ANSI B 16-104 Class IV (St.St. seat and St.St. seal)

Material

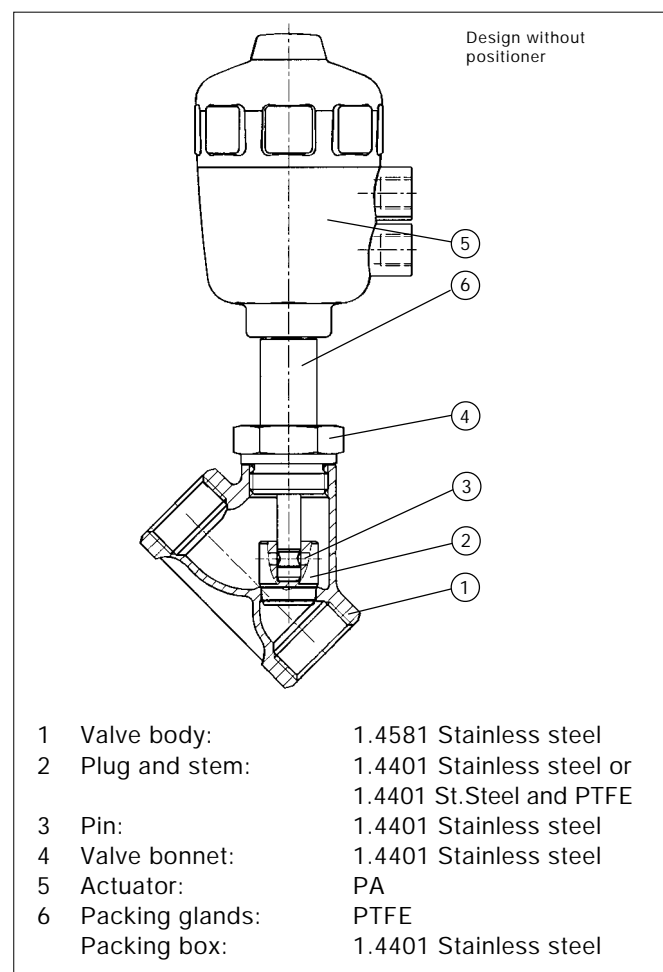

Ordering Chart

Orifice DN [mm]	Actuator-size [mm]	Max. op. pressure [bar]	Seal	Weight [kg]	Item-No. for different connections					
					G-threaded port [inch]		Weld-ends [mm]		Tri-Clamp® [mm]	
					Item-No.		Item-No.		Item-No.	
15	63	16.0	S.St./S.St.	2.7	G 1/2	420 658 N	21.3 x 1.6	420 682 X	34.0	420 676 G
			S.St./PTFE		G 1/2	416 117 G	21.3 x 1.6	416 123 E	34.0	416 129 L
20	63	16.0	S.St./S.St.	2.9	G 3/4	420 659 P	26.9 x 1.6	420 683 Y	50.5	420 677 H
			S.St./PTFE		G 3/4	416 118 R	26.9 x 1.6	416 124 F	50.5	416 130 R
25	80	16.0	S.St./S.St.	4.0	G 1	420 660 L	33.7 x 2.0	420 684 Z	50.5	420 678 J
			S.St./PTFE		G 1	416 119 J	33.7 x 2.0	416 125 G	50.5	416 131 E
32	80	16.0	S.St./S.St.	5.4	G 1 1/4	420 661 H	42.4 x 2.0	420 685 S	50.5	420 679 K
			S.St./PTFE		G 1 1/4	416 120 P	42.4 x 2.0	416 126 H	50.5	416 132 F
40	100	12.5	S.St./S.St.	6.8	G 1 1/2	420 662 A	48.3 x 2.0	420 686 T	64.0	420 680 H
			S.St./PTFE		G 1 1/2	416 121 C	48.3 x 2.0	416 127 A	64.0	416 133 G
50	100	10.0	S.St./S.St.	8.1	G 2	420 663 B	60.3 x 2.6	420 687 U	77.5	420 681 W
			S.St./PTFE		G 2	416 122 D	60.3 x 2.6	416 128 K	77.5	416 134 H

EASY Pressure Control
Flow Control
Temperature Control

EASY to commission
Automatic self-adjustment of basic parameters by finger tip control

EASY to operate
User-friendly operation
• LCD and key pad
• Menue guided access
• Programmable characteristic curves

EASY to install
Compact design
• Flanged connection using Burkert piston valves
• Delivered pre-mounted, tested and ready to install
• Requires less space than conventional control valves

Burkert Link

EASY to operate



Burkert control valve with Burkert digital flow transmitter for continuous process control.

Specifications - Flow Capacity

Plug travel [%]	Kv-value [water m ³ /h]					
	DN15	DN20	DN25	DN32	DN40	DN50
0	0.00	0.00	0.00	0.00	0.00	0.00
10	0.07	0.13	0.40	1.00	1.90	3.00
20	0.15	0.32	1.10	2.60	5.60	9.00
30	0.28	0.80	2.10	5.10	10.10	16.00
40	0.44	1.60	3.60	8.60	17.20	26.00
50	0.66	2.60	6.10	13.80	24.10	35.00
60	1.02	3.70	9.30	19.00	29.20	42.00
70	1.54	4.80	11.90	21.00	33.50	49.00
80	2.17	5.80	13.50	22.00	35.50	55.00
90	3.01	7.00	14.20	23.00	36.80	58.00
100	3.80	7.30	14.50	23.50	37.00	60.00

Dimensions [mm]

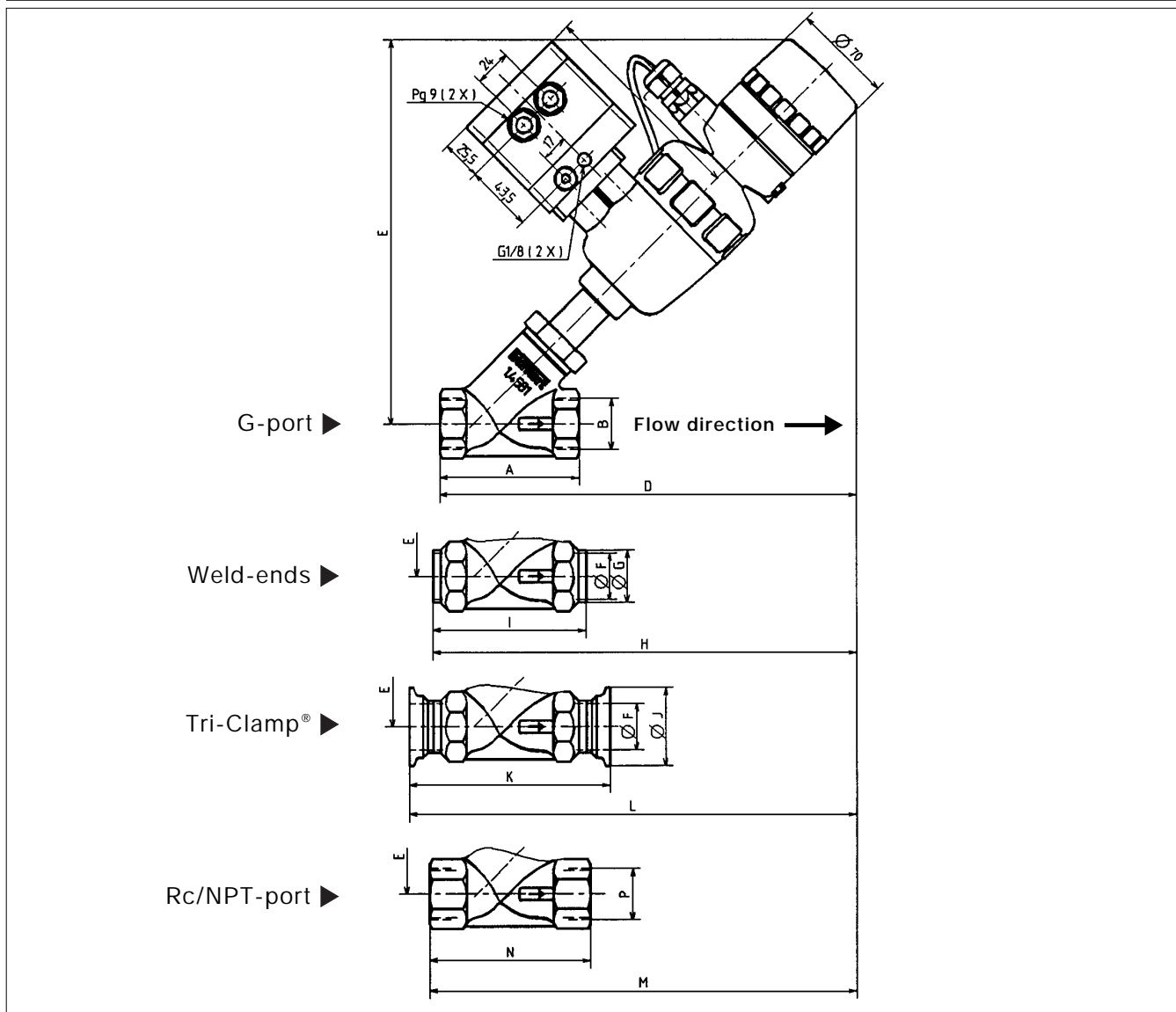

Variable dimensions [mm]

DN	Actuator size	B	P	P	A	C	D	E	øF	øG	H	I	øJ	K	L	M	N
15	63	G 1/2	Rc 1/2	NPT 1/2	65	139	262	243	18.1	21.3	267	75	34.0	106	283	269	79
20	63	G 3/4	Rc 3/4	NPT 3/4	75	139	265	246	23.7	26.9	269	83	50.5	119	287	271	87
25	80	G 1	Rc 1	NPT 1	90	147	289	267	29.7	33.7	294	99	50.5	130	310	296	104
32	80	G 1 1/4	Rc 1 1/4	NPT 1 1/4	110	147	310	273	38.4	42.4	313	115	50.5	151	331	315	120
40	100	G 1 1/2	Rc 1 1/2	NPT 1 1/2	120	160	382	325	44.3	48.3	379	115	64.0	156	400	382	120
50	100	G 2	Rc 2	NPT 2	149	160	407	339	55.1	60.3	404	144	77.5	200	432	407	149

In case of special requirements please consult for advice.

We reserve the right to make technical changes without notice.

710-GB/ 2-0024