

2/2-Way Diaphragm Valve, Pneumatically Operated Forged Stainless Steel Body with Sterile Threaded Ends

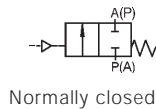

2031



DN 10 - 50

- ✓ Fully integrated in Burkert's Easy Process Control Systems
- ✓ Hermetical separation of fluids from the operating mechanism by diaphragm
- ✓ Zero dead volume
- ✓ Various surface finishes
- ✓ Quality certifications FDA /

2031

The Burkert diaphragm valve systems with forged stainless steel valve bodies are designed for control of ultra-pure, sterile, aggressive or abrasive fluids. They separate hermetically critical fluids from the actuator by chemical neutral high quality diaphragms. The zero dead volume body, combined with various surface finishes allows a wide range of applications.

The pneumatic actuator can be controlled by pneumatic pilot valves (single pilot valves, valve islands and control heads). Control function A, normally closed by spring return.

Technical Data

Connection	• DIN 11851
Pilot pressure (depending on actuator)	5.5 ... 7 bar (PPS)
	5.5 ... 10 bar (PA ≤ size 100)
	5.5 ... 7 bar (PA > size 100)
Temperatures	
	Medium -10°C ... +130°C (short +150°C)
	Ambient (depending on actuator) +5°C ... +140°C (PPS < size 100)
	+5°C ... +90°C (PPS ≥ size 100) (short +140°C)
	-10°C ... +60°C (PA)
Materials	
	Valve body Forged stainless steel 316L / 1.4435 / BN2 Fe < 0.5% / C ≤ 0.03%
Diaphragm	EPDM, PTFE
Actuator	PPS (PA on request)
Threads for pilot valves	Stainless Steel 1.4305
Flow direction	Bi-direct

Specifications

Orifice DN [mm]	Kv-Value Water [m³/h]	Max. Op. Pressure (Medium) [bar]	Actuator Size ø Diaphragm		Weight [kg]
			EPDM [mm]	PTFE [mm]	
10.0	1.0	10.0	C-40	-	0.4
10.0	1.0	10.0	-	C-40	0.4
15.0	4.0	8.5	D-50	-	0.7
15.0	4.5	10.0	-	E-63	0.9
20.0	7.0	10.0	E-63	-	1.3
20.0	7.5	10.0	-	F-80	2.0
25.0	12.0	10.0	F-80	-	2.2
25.0	12.0	7.5	-	F-80	2.2
40.0	30.0	6.5	G-100	-	4.2
40.0	30.5	10.0	-	H-125	5.7
50.0	51.5	8.0	H-125	-	7.6
50.0	51.5	7.0	-	H-125	7.6

- Applications:**
- Designed for high quality and purity requirements of:
 - Pharmaceutical industry
 - Biotechnology
 - Semicon
 - Minimum contamination in process systems



2/2-Way Diaphragm Valve, Pneumatically Operated Forged Stainless Steel Body with Sterile Threaded Ends

Dimensions [mm]

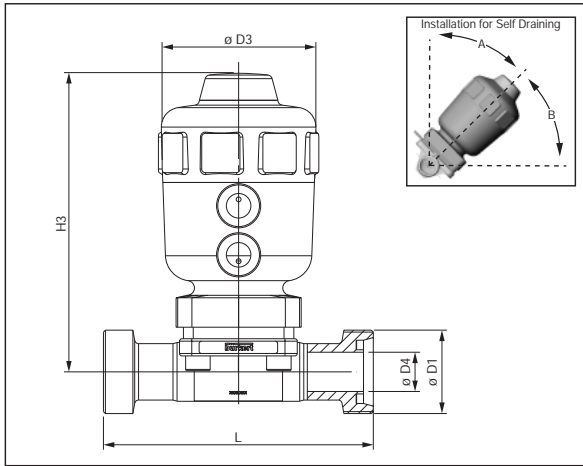

Self Draining Angles (depending on orifice)

Orifice DN	NPS	Angle -A-	Angle -B-
[mm]	[inch]		
10.0	3/8"	55°	35°
15.0	1/2"	64°	26°
20.0	3/4"	62°	28°
25.0	1"	67°	23°
40.0	1 1/2"	67°	23°
50.0	2"	68°	22°

DIN 11851 Connection

Orifice DN	Actuator size ø	L	D1 ø	D4 ø	D3 ø	H3
[mm]	[mm]	[mm]	[mm]	[mm]	[mm]	[mm]
10.0	C-40	90.0	28x1/8"	10.0	53.0	85.0
15.0	D-50	110.0	34x1/8"	16.0	64.0	121.0
15.0	E-63	110.0	34x1/8"	16.0	80.0	138.0
20.0	E-63	120.0	44x1/6"	20.0	80.0	148.0
20.0	F-80	120.0	44x1/6"	20.0	101.0	174.0
25.0	E-63	129.0	52x1/6"	26.0	80.0	157.0
25.0	F-80	129.0	52x1/6"	26.0	101.0	177.0
40.0	G-100	160.0	65x1/6"	38.0	127.0	233.0
40.0	H-125	160.0	65x1/6"	38.0	153.0	272.0
50.0	G-100	190.0	78x1/6"	50.0	127.0	244.0
50.0	H-125	190.0	78x1/6"	50.0	153.0	278.0

Specifications - Ordering Chart (Other Versions on Request) for DIN 11851 Connection

Orifice DN	Connection D1	Surface finish [µm]	*1. Standard – Satin finished *2. Electro polished *3. Mech. polished – Satin finished *4. Electro polished *5. Mirror finished	Actuator size	Item-No.	
					Pneumatic EPDM Diaphragm	Actuator PTFE Diaphragm
10.0	Rd 28 x 1/8"	*1. External Ra<6.3	- Internal Ra<0.5	C-40	446 707 E	447 310 C
10.0	Rd 28 x 1/8"	*2. External Ra<3.2	- Internal Ra<0.4	C-40	446 708 P	447 311 Z
10.0	Rd 28 x 1/8"	*3. External Ra<1.6	- Internal Ra<0.5	C-40	446 709 Q	447 312 S
10.0	Rd 28 x 1/8"	*4. External Ra<0.8	- Internal Ra<0.4	C-40	446 710 C	447 313 T
10.0	Rd 28 x 1/8"	*5. External Ra<0.25	- Internal Ra<0.25	C-40	446 711 Z	447 314 U
15.0	Rd 34 x 1/8"	*1. External Ra<6.3	- Internal Ra<0.5	D-50	446 712 S	447 315 V
15.0	Rd 34 x 1/8"	*2. External Ra<3.2	- Internal Ra<0.4	D-50	446 713 T	447 316 W
15.0	Rd 34 x 1/8"	*3. External Ra<1.6	- Internal Ra<0.5	D-50	446 714 U	447 317 X
15.0	Rd 34 x 1/8"	*4. External Ra<0.8	- Internal Ra<0.4	D-50	446 715 V	447 318 G
15.0	Rd 34 x 1/8"	*5. External Ra<0.25	- Internal Ra<0.25	D-50	446 716 W	447 319 H
20.0	Rd 44 x 1/6"	*1. External Ra<6.3	- Internal Ra<0.5	E-63	446 717 X	447 320 E
20.0	Rd 44 x 1/6"	*2. External Ra<3.2	- Internal Ra<0.4	E-63	446 718 G	447 321 T
20.0	Rd 44 x 1/6"	*3. External Ra<1.6	- Internal Ra<0.5	E-63	446 719 H	447 322 U
20.0	Rd 44 x 1/6"	*4. External Ra<0.8	- Internal Ra<0.4	E-63	446 720 E	447 323 V
20.0	Rd 44 x 1/6"	*5. External Ra<0.25	- Internal Ra<0.25	E-63	446 721 T	447 324 W
25.0	Rd 52 x 1/6"	*1. External Ra<6.3	- Internal Ra<0.5	F-80	446 722 U	447 325 X
25.0	Rd 52 x 1/6"	*2. External Ra<3.2	- Internal Ra<0.4	F-80	446 723 V	447 326 Y
25.0	Rd 52 x 1/6"	*3. External Ra<1.6	- Internal Ra<0.5	F-80	446 724 W	447 327 Z
25.0	Rd 52 x 1/6"	*4. External Ra<0.8	- Internal Ra<0.4	F-80	446 725 X	447 328 A
25.0	Rd 52 x 1/6"	*5. External Ra<0.25	- Internal Ra<0.25	F-80	446 726 Y	447 329 B
40.0	Rd 65 x 1/6"	*1. External Ra<6.3	- Internal Ra<0.5	G-100	446 727 Z	447 330 G
40.0	Rd 65 x 1/6"	*2. External Ra<3.2	- Internal Ra<0.4	G-100	446 728 A	447 331 V
40.0	Rd 65 x 1/6"	*3. External Ra<1.6	- Internal Ra<0.5	G-100	446 729 B	447 332 W
40.0	Rd 65 x 1/6"	*4. External Ra<0.8	- Internal Ra<0.4	G-100	446 730 G	447 333 X
40.0	Rd 65 x 1/6"	*5. External Ra<0.25	- Internal Ra<0.25	G-100	446 731 V	447 334 Y
50.0	Rd 78 x 1/6"	*1. External Ra<6.3	- Internal Ra<0.5	H-125	446 732 W	447 335 Z
50.0	Rd 78 x 1/6"	*2. External Ra<3.2	- Internal Ra<0.4	H-125	446 733 X	447 336 S
50.0	Rd 78 x 1/6"	*3. External Ra<1.6	- Internal Ra<0.5	H-125	446 734 Y	447 337 T
50.0	Rd 78 x 1/6"	*4. External Ra<0.8	- Internal Ra<0.4	H-125	446 735 Z	447 338 C
50.0	Rd 78 x 1/6"	*5. External Ra<0.25	- Internal Ra<0.25	H-125	446 736 S	447 339 D

In case of special application requirements, please consult for advice.

We reserve the right to make technical changes without notice.
105-GB/ 1-0XXX