



Advantages / Benefits

- ▶ Installation to profiled DIN-rail DIN 46 277
- ▶ Compact design
- ▶ Supply voltage 115, 230 V/50-60 Hz
- ▶ Outputs:
 - 2 x 24 V/0.3 A
 - 1 x 12 V/0.1 A

Design

The 24 V-outputs have independent voltage controllers allowing individual output. The load current of one output may be increased up to 600 mA, as long as the other remains unused.

The 12 V-output can, for instance, be used to supply a transmitter.

Applications

For all applications requiring voltage and power supply coupled with a DIN rail mounting for use in control cabinets e.g.

- Power supply for i.e.:
- Solenoid control valves
 - PI-controller 8623, 8624, 8625
 - PID-controller 1067
 - Flow sensors/transmitter
 - Level sensors/transmitter
 - Analysis sensors/transmitter
 - Pressure sensors/transmitter

Example:

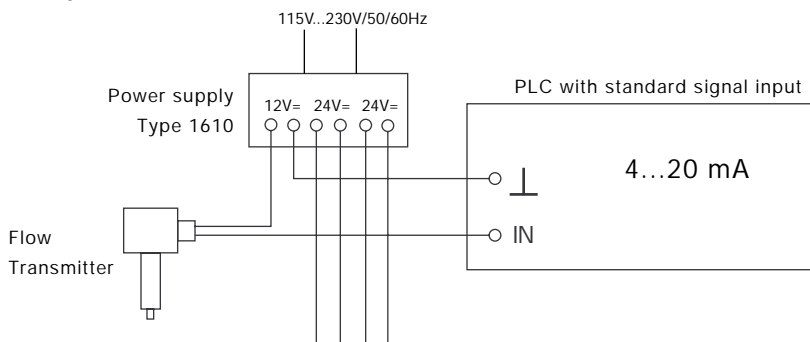

Power Supply

Technical Data

Voltage Supply

Supply voltage	115 or 230 V/50-60 Hz $\pm 10\%$
Power consumption	< 100 mA (with load current)
Special feature	input voltage reversible via bridge or ext. switch
Isolation group	VDE 0551 (EN 60 742)
Voltage resistance	VDE 0160 1.5 kV
Protective circuit	IEC 801-4 (burst) IEC 801-5 (high-energy) VDE 0875 (electro-magnetic radiation)

Design	standard DIN-rail enclosure for installation to 35 mm mounting rail (DIN 46 277)
--------	--

Rating	IP00
Electrical connection	terminal screws 1.5 mm ²
Ambient temperature	-20 ... +85 °C
Weight	0.7 kg

Item-No. 007 999 X

Outputs 1 and 2

Output type	standard voltage controller
Load current	per 300 mA
Output voltage	per 24 V/=
Residual ripple	< 5 mV
Fuse protection	per 400 mA/ medium slow-blow
Special features	depending on weight with other outputs If either output 1 or 2 remains unused, the other can be loaded by 600 mA, after replacing the 400 mA safety fuse by an 800 mA.

Outputs 3 and 4

Output type	standard voltage controller
Total load current	100 mA
Output voltage	per 12 V/=
Residual ripple	< 5 mV
Fuse protection	100 mA/medium slow-blow
Special features	<ul style="list-style-type: none"> depending on weight with other outputs dep. on voltage controller for outputs 3 and 4 dep. on safety fuse for outputs 3 and 4

Dimensions in mm

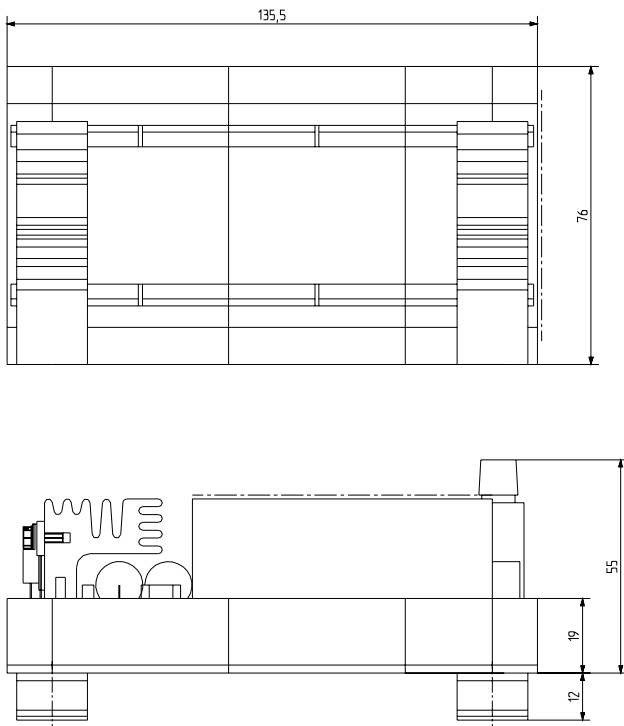

Pin Assignment

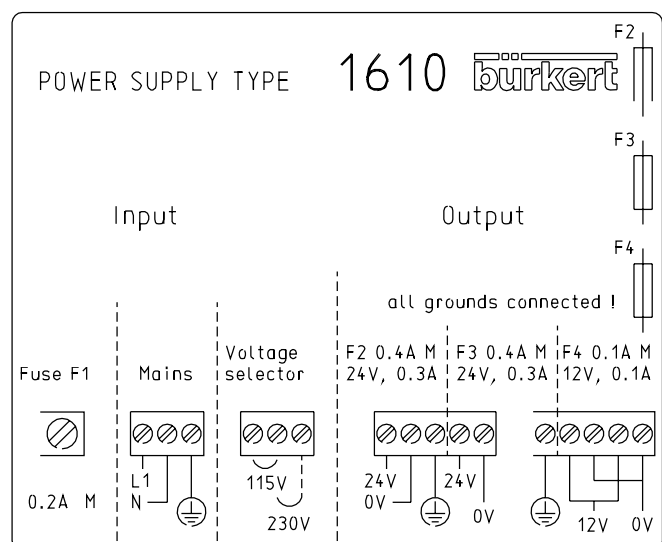

In case of special requirements please consult for advice.

We reserve the right to make technical changes without notice.
710-GB/ 1-0092