

2/2-Way, G1/2, Solven joint



Advantages/Benefits

- ▶ Normally closed
- ▶ Body material: PVC
- ▶ No differential pressure required for switching
- ▶ Double seal to valve internal
- ▶ Non-metallic valve internals
- ▶ Lockable manual override standard
- ▶ Simple, space-saving installation

Design/Function

The Type 141 solenoid valve with coupled valve operation is available in normally-closed. i.e. when de-energized, the valve is closed by the fluid pressure, supported by the spring action. A diaphragm isolates the actuator from the fluid. When energized, the space above the diaphragm is exhausted, the diaphragm is lifted by the fluid pressure and the valve opens.

The solenoid epoxy encapsulation efficiently dissipates the heat generated by the coil.

Applications

- Aggressive gases and liquids
- De-ionised water
- For varying differential pressure
- Water treatment
- Chemical cleaning and washing systems
- Beverage industry
- Photochemistry
- Agricultural industry
- Food industry

bürkert
Easy Fluid Control Systems

Solenoid Valve for Aggressive Fluids, with coupled Valve Operation

Type 141

Technical Data

Circuit Function

A 2/2-way valve,
normally closed,
with 2-way assisted lift.

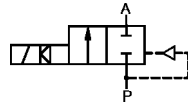

Body Material

Rigid PVC (resistant to DIN 8062 and DIN 8061)
Solenoid actuator isolated from the fluid by double
seal with ventilated mid-chamber.

Specifications

Orifice DN [mm]	Kv-Value Water [m ³ /h]	QnN-Value Air [l/min]	Pressure Range [bar]	Weight [kg]
	3,5	3700		
15	3,5	3700	0-6	1,25
20	5,5	5900	0-6	1,25
25	10,5	11300	0-6	1,75
32	15,5	16700	0-6	1,75

All pressures quoted are gauge pressures with respect to the prevailing atmospheric pressure.

Operating Data (Valve)

Seal Material/Fluids Handled/Temp.- Range

NBR Neutral fluids, e.g. compressed air, town gas,
water, hydraulic oil, oils and fats without
additives -10 to +50 °C

EPDM Alkalis, acids to medium concentration,
alkaline washing and bleaching lyes
-30 to +50 °C

FPM Oxidizing acids and substances,
salt solutions, oils with additives
-10 to +50 °C

For more detailed information see resistance chart
(Leaflet No. 1896009).

Max. ambient temperature +50 °C

Max. viscosity approx. 37 mm²/s

Response times opening: 0,15 - 0,2 s
closing: for 0,2 bar: 0,8 - 1,3 s
for 6 bar: 0,2 - 0,4 s

The response times have been measured with water.
They depend upon the orifice as well as the pressure
and viscosity of the handled fluid.

Port connection solvent joint DIN 8063
20, 25, 32, 40 mm ø

Operating Data (Actuator)

Operating voltage 24, 42, 48, 110, 220,
240 V/UC (universal current)

Voltage tolerance ±10 %

Power consumption inrush 100 W, hold 9 W

Duty cycle 100 % continuously rated

Cycling rate 10 c.p.m.

Rating IP 65 cable plug

Installation/Accessories

Installation as required

Electrical connection with cable plug to
DIN 43 650 supplied as
standard

The valve is supplied with a lockable manual override.
Electrical position indication on request.

Solenoid Valve for Aggressive Fluids, with coupled Valve Operation

Type 141

Dimensions in mm

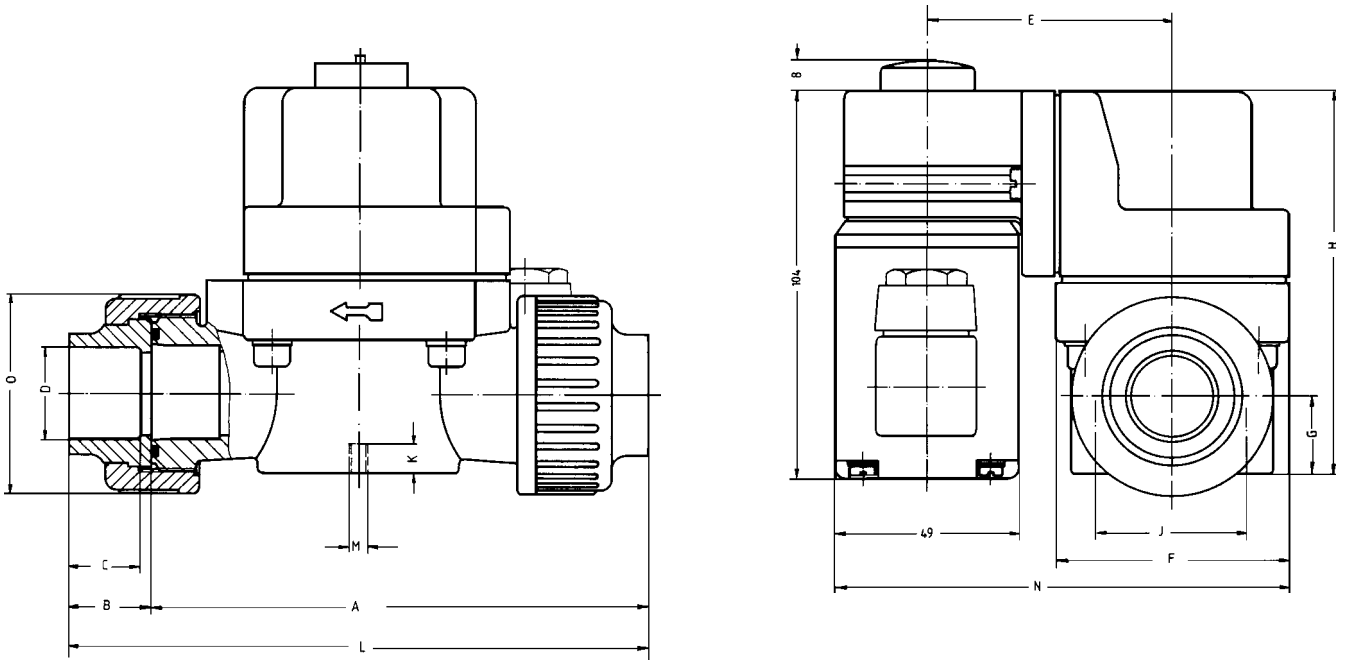

Orifice [mm]	A	B	C	D	D 1	E	F	G	H	J	K	L	M	N	O
15	110	19	16	20,2	25,2	65	62	21	102	40	8	148	M 5	120	53
20	110	22	19	25,2	25,2	65	62	21	102	40	8	154	M 5	120	53
25	140	25	22	32,2	40,2	76	85	30	120	44,5	15	190	M 8	143	74
32	140	29	26	40,2	40,2	76	85	30	120	44,5	15	198	M 8	143	74

Pressure - Temperature - Diagram

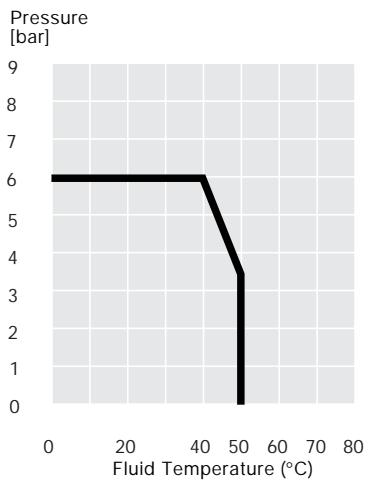

Solenoid Valve for Aggressive Fluids, with coupled Valve Operation

Type 141

Ordering Chart (Other Versions on Request)

Circuit Function	Orifice DN [mm]	Flow Rate		Port Connection	Pressure Range [bar]	Body Material	Seal Material	Weight [kg]	Voltage/ Frequency [V/Hz]	Order-No.
		Water Kv-Value [m³/h]	Air Qn [l/min]							
A	15,0	3,5	3700	G 1/2	0-6	PVC	EPDM	1,25	220/UC	054 810 T
					0-6	PVC	EPDM	1,25	024/UC	050 535 T
				¹⁾ 20 mm ø	110/UC	049 753 Q				
					220/UC	048 682 H				
					240/UC	050 055 D				
					NBR	1,25	042/UC	059 570 P		
	FPM	1,25	024/UC	049 107 A						
	110/UC	063 190 X								
	220/UC	040 771 M								
	20,0	5,5	5900	¹⁾ 25 mm ø	0-6	PVC	EPDM	1,25	024/UC	047 688 E
									048/UC	048 685 C
					110/UC	047 497 P				
220/UC					048 668 S					
240/UC					050 867 G					
NBR					1,25	220/UC	045 872 U			
FPM		1,25	024/UC	047 814 L						
110/UC		048 209 X								
220/UC		045 967 T								
240/UC		049 153 F								
25,0		10,5	11300	¹⁾ 32 mm ø	0-6	PVC	EPDM	1,75	024/UC	048 364 R
									110/UC	052 195 M
	220/UC				048 683 A					
	240/UC				058 402 B					
	FPM				1,25	024/UC	047 066 Z			
	110/UC				056 349 J					
	220/UC	045 962 W								
	240/UC	049 891 U								
	32,0	15,5	16700	¹⁾ 40 mm ø	0-6	PVC	EPDM	1,75	024/UC	058 902 G
									110/UC	058 863 G
					220/UC	048 684 B				
					240/UC	049 800 M				
FPM					1,75	024/UC	045 731 W			
048/UC					064 888 Y					
110/UC		048 243 Q								
220/UC		048 015 X								
240/UC		053 846 S								

¹⁾ Solvent joint DIN 8063 ø 20 mm