

2/2-Way Globe Control Valve, Pneumatically Operated Cast Stainless Steel Body with Weld Ends

PRELIMINARY
Index 22
dd. 17.04.01

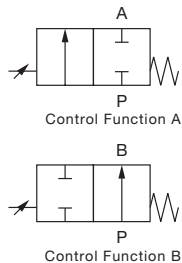

2712



DN 10 – 50

- ✓ Fully integrated in Burkert's Easy Process Control Systems
- ✓ New generation with interchangeable trims, all in stainless steel
- ✓ Integrated, cascade process controller with PID algorithm
- ✓ Automatic self-adjustment of basic parameters means autotune for the valve and for PID
- ✓ Quality certifications available

Picture showing a complete Burkert System using Type 2712 with TOP Control 8630

Control valve 2712 consists of a globe valve body with pneumatic piston actuator. The trim is in the form of a parabolic plug/seat system. This results in a favourable characteristic for continuous variation of the flow as a function of the parabolic plug position. Type 2712 can be actuated by the Continuous TOP Control type 8630 or SIDE Control Type 1067 and 8635. TOP Control/SIDE Control thus forms a mechanical and functional unit with the pneumatic actuator as a complete control valve system. With this control valve system, every need in the continuous control of fluids can be solved.

Process Specification

Materials

Body

Cast Stainless Steel 316 L
(conform to 1.4409)

Actuator

PA

Sealing

- SS/SS
- PTFE/SS

Process media (for gases and liquids)

- For neutral gases, water, alcohols, oils, fuels, hydraulic liquids, salt solutions, lyes, organic solvents, steam (10 bar/+180 °C)

Viscosity

Max. 600 mm²/s

Packing gland

PTFE V-rings (silicone grease) with spring compensation

Nominal pressure

PN 25 (body)

Temperatures

Fluid

-10°C... +180°C

Ambient

-10°C... +60°C

Control media

Instrument air class of 3
DIN ISO 8573-1

Pilot pressure

5.5... 7 bar

Threads

G 1/4 stainless steel (ss)

Flow direction

Below seat

Interchangeable seat

Different Kvs-values per port size

Valve characteristics

See flow-rate characteristics on page 2

Control ratio

Kvs/Kvo 50:1

Seatleakage IEC 534-4/EN 1349

Shut-off class IV for SS/SS
Shut-off class VI for PTFE/SS

Port connections

Weld End

- ISO
- DIN
- OD
- ASME
- JIS

- ISO 4200
- DIN 11850 series 2
- BS 4825 part 1
- ASME BPE
- JIS 3459 or 3447 (on request)

Applications: Food & Beverage

- CIP / SIP; Steam
- Auxiliary Processes

Water Treatment

- Air Control
- Chemical Dosing

Cosmetics

- CIP / SIP; Steam

Textile

- Steam; Water; Air; Dyeing



Port size (tube) (ISO/DIN) [mm]	Orifice DN (seat) [mm]			Actuator size [mm]	Kvs-value water [m ³ /h]			Weight with controller 8630 (ISO/DIN) [kg]
	1	2	3		1	2	3	
10	-	8	10	F-80	-	2.0	2.7	2.9
15	8	10	15	F-80	2.1	3.1	4.3	2.9
20	10	15	20	F-80	3.2	5.2	7.1	3.0
25	15	20	25	F-80	5.3	7.2	12.0	3.6
32	20	25	32	G-100	8.0	13.0	17.8	6.4
40	25	32	40	G-100	13.6	20.2	23.8	7.0
50	32	40	50	H-125	21.0	24.6	37.0	10.8

Port size (tube) (BS 4825/ ASME BPE) [mm] [inch]	Orifice DN (seat) [mm]			Actuator size [mm]	Kvs-value water [m ³ /h]			Weight with controller 8630 (BS 4825/ ASME BPE) [kg]
	1	2	3		1	2	3	
15 1/2"	-	8	10	F-80	-	2.0	2.7	2.9
20 3/4"	8	10	15	F-80	2.1	3.1	4.3	2.9
25 1"	10	15	20	F-80	3.2	5.2	7.1	3.0
40 1 1/2"	20	25	32	G-100	8.0	13.0	17.8	6.4
50 2"	25	32	40	G-100	13.6	20.2	23.8	7.0

2/2-Way Globe Control Valve, Pneumatically Operated Cast Stainless Steel Body with Weld Ends

Flow curve and description

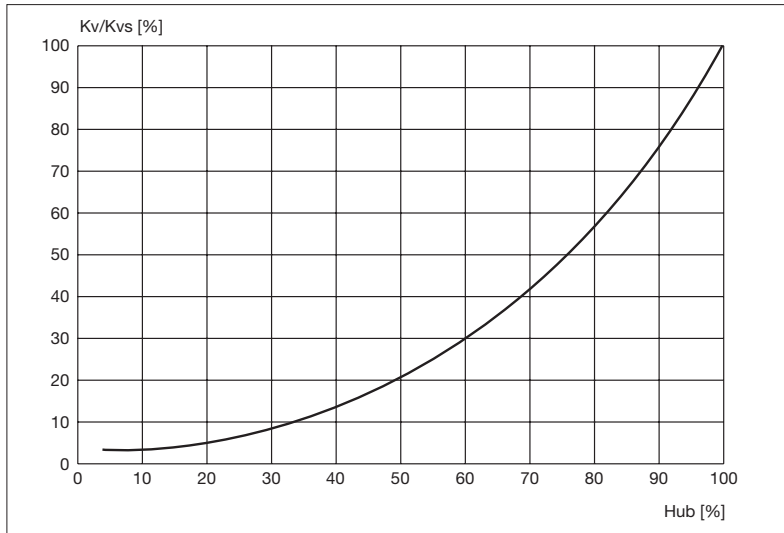

Remarks on the flow characteristic

- Equipercentile parabolic plug; linear plug can also be supplied
- Flow characteristic runs within DIN/IEC 534-2-4
- Theoretical control ratio $Kvs/Kvo = 50 : 1$ other control ratios can also be realized
- Kvr value at 5% of stroke for $DN > 10$ mm
 Kvr value at 10% of stroke for $DN \leq 10$ mm
(Kvr value = smallest Kv value at which the gradient tolerance to DIN/IEC 534-2-4 is still complied with)

Kv values [m3/h]

Port size (tube)			Orifice (seat)			Stroke [%]										
ISO 4200/DIN 11850		BS 4825/ASME BPE		(seat)		5	10	20	30	40	50	60	70	80	90	100
[mm]	[inch]	[mm]	[inch]	[mm]	[inch]											
10	3/8"	15	1/2"	8	1/4"	0.06	0.07	0.09	0.12	0.18	0.26	0.42	0.61	0.92	1.5	2.0
10	3/8"	15	1/2"	10	3/8"	0.09	0.11	0.13	0.19	0.30	0.48	0.73	1.00	1.60	2.3	2.7
15	1/2"	20	3/4"	8	1/4"	0.07	0.08	0.11	0.13	0.19	0.27	0.43	0.63	0.95	1.6	2.1
15	1/2"	20	3/4"	10	3/8"	0.09	0.11	0.15	0.19	0.31	0.49	0.75	1.10	1.70	2.5	3.1
15	1/2"	20	3/4"	15	1/2"	0.14	0.17	0.22	0.35	0.52	0.80	1.20	1.80	2.70	3.7	4.3
20	3/4"	25	1"	10	3/8"	0.11	0.12	0.16	0.20	0.33	0.52	0.77	1.20	1.80	2.6	3.2
20	3/4"	25	1"	15	1/2"	0.14	0.17	0.22	0.35	0.52	0.80	1.20	1.80	2.90	4.0	5.2
20	3/4"	25	1"	20	3/4"	0.20	0.25	0.30	0.45	0.70	1.10	1.60	2.40	3.50	5.2	7.1
25	1"	-	-	15	1/2"	0.14	0.17	0.22	0.35	0.52	0.80	1.20	1.80	2.90	4.1	5.3
25	1"	-	-	20	3/4"	0.20	0.25	0.31	0.47	0.70	1.10	1.60	2.50	3.80	5.4	7.2
25	1"	-	-	25	1"	0.35	0.38	0.65	1.00	1.50	2.20	3.40	5.10	7.00	9.4	12.0
32	1 1/4"	40	1 1/2"	20	3/4"	0.22	0.25	0.35	0.50	0.75	1.10	1.60	2.50	3.80	5.8	8.0
32	1 1/4"	40	1 1/2"	25	1"	0.40	0.47	0.73	1.10	1.60	2.50	3.70	5.40	7.50	10.3	13.0
32	1 1/4"	40	1 1/2"	32	1 1/4"	0.48	0.60	0.85	1.30	2.10	3.10	4.50	6.80	10.20	14.0	17.8
40	1 1/2"	50	2"	25	1"	0.40	0.50	0.75	1.10	1.70	2.60	3.80	5.60	8.00	10.7	13.6
40	1 1/2"	50	2"	32	1 1/4"	0.48	0.60	0.85	1.30	2.10	3.20	4.60	6.90	11.00	15.0	20.2
40	1 1/2"	50	2"	40	1 1/2"	0.60	0.70	1.10	1.70	2.70	4.00	6.00	9.20	13.80	18.2	23.8
50	2"	-	-	32	1 1/4"	0.48	0.60	0.90	1.30	2.10	3.20	4.60	6.90	11.60	16.0	21.0
50	2"	-	-	40	1 1/2"	0.60	0.70	1.00	1.70	2.60	4.00	5.90	9.20	14.00	18.9	24.6
50	2"	-	-	50	2"	0.90	1.10	1.90	2.90	4.50	6.80	10.50	15.50	22.00	29.3	37.0

2/2-Way Globe Control Valve, Pneumatically Operated Cast Stainless Steel Body with Weld Ends

Ordering chart: Globe Valve Systems

Weld End • ISO 4200						Flow below seat	
Circuit Function	Port size (tube) [mm]	Orifice DN (seat) [mm]	Connection D1 x S [mm]	Actuator size ø [mm]	Op. pressure ≤+180°C [bar]	Item-No. seal system* SS/SS	Item-No. seal system* PTFE/SS
A	10	8	17.2 x 1.6	F-80	16.0	146 672 D	146 958 C
	10	10	17.2 x 1.6	F-80	16.0	146 694 U	146 982 M
	15	8	21.3 x 1.6	F-80	16.0	145 832 M	146 970 C
	15	10	21.3 x 1.6	F-80	16.0	146 706 G	146 994 R
	15	15	21.3 x 1.6	F-80	16.0	146 734 T	147 022 N
	20	10	26.9 x 1.6	F-80	16.0	146 720 H	147 008 H
	20	15	26.9 x 1.6	F-80	16.0	146 748 R	147 036 L
	20	20	26.9 x 1.6	F-80	16.0	146 776 D	147 064 Y
	25	15	33.7 x 2.0	F-80	16.0	146 762 F	147 050 E
	25	20	33.7 x 2.0	F-80	16.0	146 790 G	147 078 E
	25	25	33.7 x 2.0	F-80	16.0	146 016 P	147 104 W
	32	20	42.4 x 2.0	G-100	16.0	146 804 T	147 092 M
	32	25	42.4 x 2.0	G-100	16.0	146 828 S	147 118 T
	32	32	42.4 x 2.0	G-100	16.0	146 854 U	147 144 V
	40	25	48.3 x 2.0	G-100	16.0	146 840 A	147 130 T
	40	32	48.3 x 2.0	G-100	16.0	146 866 Y	147 155 Y
	40	40	48.3 x 2.0	G-100	16.0	146 894 M	147 183 M
	50	32	60.3 x 2.0	H-125	16.0	146 880 T	147 169 E
	50	40	60.3 x 2.0	H-125	16.0	146 908 B	147 200 J
	50	50	60.3 x 2.0	H-125	16.0	146 921 P	147 214 T
B	10	8	17.2 x 1.6	F-80	16.0	146 678 K	146 964 S
	10	10	17.2 x 1.6	F-80	16.0	146 700 N	146 988 T
	15	8	21.3 x 1.6	F-80	16.0	146 688 E	146 976 W
	15	10	21.3 x 1.6	F-80	16.0	146 713 W	147 001 S
	15	15	21.3 x 1.6	F-80	16.0	146 741 A	147 029 V
	20	10	26.9 x 1.6	F-80	16.0	146 727 U	147 015 P
	20	15	26.9 x 1.6	F-80	16.0	146 755 G	147 043 T
	20	20	26.9 x 1.6	F-80	16.0	146 783 V	147 071 X
	25	15	33.7 x 2.0	F-80	16.0	146 769 N	147 057 Z
	25	20	33.7 x 2.0	F-80	16.0	146 797 T	147 085 N
	25	25	33.7 x 2.0	F-80	16.0	146 821 K	147 111 L
	32	20	42.4 x 2.0	G-100	16.0	146 810 U	147 098 T
	32	25	42.4 x 2.0	G-100	16.0	146 834 Q	147 124 R
	32	32	42.4 x 2.0	G-100	16.0	146 860 E	147 150 F
	40	25	48.3 x 2.0	G-100	16.0	146 847 V	147 137 N
	40	32	48.3 x 2.0	G-100	16.0	146 873 X	147 162 X
	40	40	48.3 x 2.0	G-100	16.0	146 901 U	147 193 P
	50	32	60.3 x 2.0	H-125	16.0	146 887 N	147 176 V
	50	40	60.3 x 2.0	H-125	16.0	146 915 R	147 207 D
	50	50	60.3 x 2.0	H-125	16.0	146 927 M	147 221 S



Continuous Globe valve

2712

Weld End • DIN 11850 series 2						Flow below seat	
Circuit Function	Port size (tube) [mm]	Orifice DN (seat) [mm]	Connection D1 x S [mm]	Actuator size ø [mm]	Op. pressure ≤+180°C [bar]	Item-No. seal system* SS/SS	Item-No. seal system* PTFE/SS
A	10	8	13 x 1.5	F-80	16.0	146 673 E	146 959 D
	10	10	13 x 1.5	F-80	16.0	146 695 V	146 983 N
	15	8	19 x 1.5	F-80	16.0	146 683 Z	146 971 Z
	15	10	19 x 1.5	F-80	16.0	146 707 H	146 995 J
	15	15	19 x 1.5	F-80	16.0	146 735 U	147 023 P
	20	10	23 x 1.5	F-80	16.0	146 721 W	147 009 A
	20	15	23 x 1.5	F-80	16.0	146 749 J	147 037 M
	20	20	23 x 1.5	F-80	16.0	146 777 E	147 065 Z
	25	15	29 x 1.5	F-80	16.0	146 763 G	147 051 T
	25	20	29 x 1.5	F-80	16.0	146 791 V	147 079 F
	25	25	29 x 1.5	F-80	16.0	145 664 C	147 105 X
	32	20	35 x 1.5	G-100	16.0	146 805 U	147 093 N
	32	25	35 x 1.5	G-100	16.0	146 829 T	147 119 U
	32	32	35 x 1.5	G-100	16.0	146 855 V	147 145 W
	40	25	41 x 1.5	G-100	16.0	146 841 X	147 131 Q
	40	32	41 x 1.5	G-100	16.0	146 867 Z	147 156 Z
	40	40	41 x 1.5	G-100	16.0	146 895 N	147 187 R
	50	32	53 x 1.5	H-125	16.0	146 881 Q	147 170 B
	50	40	53 x 1.5	H-125	16.0	146 909 C	147 201 F
	50	50	53 x 1.5	H-125	16.0	145 665 D	147 215 U
B	10	8	13 x 1.5	F-80	16.0	146 679 L	146 965 T
	10	10	13 x 1.5	F-80	16.0	146 701 B	146 989 U
	15	8	19 x 1.5	F-80	16.0	146 689 F	146 977 X
	15	10	19 x 1.5	F-80	16.0	146 714 X	147 002 T
	15	15	19 x 1.5	F-80	16.0	146 742 B	147 030 S
	20	10	23 x 1.5	F-80	16.0	146 728 D	147 016 Q
	20	15	23 x 1.5	F-80	16.0	146 756 H	147 044 U
	20	20	23 x 1.5	F-80	16.0	146 784 W	147 072 Y
	25	15	29 x 1.5	F-80	16.0	146 770 K	147 058 A
	25	20	29 x 1.5	F-80	16.0	146 798 C	147 086 P
	25	25	29 x 1.5	F-80	16.0	146 822 L	147 112 M
	32	20	35 x 1.5	G-100	16.0	146 811 R	147 099 U
	32	25	35 x 1.5	G-100	16.0	146 835 R	147 125 J
	32	32	35 x 1.5	G-100	16.0	146 861 T	147 151 U
	40	25	41 x 1.5	G-100	16.0	146 848 E	147 138 X
	40	32	41 x 1.5	G-100	16.0	146 874 Y	147 163 Y
	40	40	41 x 1.5	G-100	16.0	146 902 V	147 194 Q
	50	32	53 x 1.5	H-125	16.0	146 888 X	147 177 W
	50	40	53 x 1.5	H-125	16.0	146 916 J	147 208 N
	50	50	53 x 1.5	H-125	16.0	146 928 W	147 222 T

*seal system: SS/SS plug stainless steel / seat stainless steel
PTFE/SS plug PTFE / seat stainless steel



2/2-Way Globe Control Valve, Pneumatically Operated Cast Stainless Steel Body with Weld Ends

Ordering chart: Globe Valve Systems

Weld End • BS 4825 part 1						Flow below seat		
Circuit Function	Port size (tube) [mm] [inch]	Orifice DN (seat) [mm] [inch]	Connection D1 x S [mm]	Actuator size ø [mm]	Op. pressure ≤+180°C [bar]	Item-No. seal system* SS/SS	Item-No. seal system* PTFE/SS	
A	15 1/2"	8 1/4"	12.70 x 1.2	F-80	16.0	146 708 J	146 996 K	
	15 1/2"	10 3/8"	12.70 x 1.2	F-80	16.0	146 736 V	147 024 Q	
	20 3/4"	8 1/4"	19.05 x 1.2	F-80	16.0	146 722 X	147 010 W	
	20 3/4"	10 3/8"	19.05 x 1.2	F-80	16.0	146 750 P	147 038 W	
	20 3/4"	15 1/2"	19.05 x 1.2	F-80	16.0	146 778 P	147 066 S	
	25 1"	10 3/8"	25.40 x 1.6	F-80	16.0	146 764 H	147 052 U	
	25 1"	15 1/2"	25.40 x 1.6	F-80	16.0	146 792 W	147 080 V	
	25 1"	20 3/4"	25.40 x 1.6	F-80	16.0	146 816 N	147 106 Y	
	40 1 1/2"	20 3/4"	38.10 x 1.6	G-100	16.0	146 842 Y	147 132 R	
	40 1 1/2"	25 1"	38.10 x 1.6	G-100	16.0	146 868 A	147 157 S	
	40 1 1/2"	32 1 1/4"	38.10 x 1.6	G-100	16.0	146 896 P	147 188 S	
	50 2"	25 1"	50.80 x 1.6	H-125	16.0	146 882 R	147 171 Y	
	50 2"	32 1 1/4"	50.80 x 1.6	H-125	16.0	146 910 Y	147 202 G	
	50 2"	40 1 1/2"	50.80 x 1.6	H-125	16.0	146 922 Q	147 216 V	
	B	15 1/2"	8 1/4"	12.70 x 1.2	F-80	16.0	146 715 Y	147 003 U
		15 1/2"	10 3/8"	12.70 x 1.2	F-80	16.0	146 743 C	147 031 P
		20 3/4"	8 1/4"	19.05 x 1.2	F-80	16.0	146 729 E	147 017 R
		20 3/4"	10 3/8"	19.05 x 1.2	F-80	16.0	146 757 A	147 045 V
		20 3/4"	15 1/2"	19.05 x 1.2	F-80	16.0	146 785 X	147 073 Z
		25 1"	10 3/8"	25.40 x 1.6	F-80	16.0	146 771 G	147 059 B
25 1"		15 1/2"	25.40 x 1.6	F-80	16.0	146 799 D	147 087 Q	
25 1"		20 3/4"	25.40 x 1.6	F-80	16.0	146 823 M	147 113 N	
40 1 1/2"		20 3/4"	38.10 x 1.6	G-100	16.0	146 849 F	147 139 Y	
40 1 1/2"		25 1"	38.10 x 1.6	G-100	16.0	146 875 Z	147 164 Z	
40 1 1/2"		32 1 1/4"	38.10 x 1.6	G-100	16.0	146 903 W	147 195 R	
50 2"		25 1"	50.80 x 1.6	H-125	16.0	146 889 Y	147 178 F	
50 2"		32 1 1/4"	50.80 x 1.6	H-125	16.0	146 917 K	147 209 P	
50 2"		40 1 1/2"	50.80 x 1.6	H-125	16.0	146 929 X	147 223 U	



Weld End • ASME BPE (1" up to 2" same as BS 4825)						Flow below seat		
Circuit Function	Port size (tube) [mm] [inch]	Orifice DN (seat) [mm] [inch]	Connection D1 x S [mm]	Actuator size ø [mm]	Op. pressure ≤+180°C [bar]	Item-No. seal system* SS/SS	Item-No. seal system* PTFE/SS	
A	15 1/2"	8 1/4"	12.70 x 1.6	F-80	16.0	151 863 S	151 853 Y	
	15 1/2"	10 3/8"	12.70 x 1.6	F-80	16.0	151 864 T	151 854 Z	
	20 3/4"	8 1/4"	19.05 x 1.6	F-80	16.0	151 865 U	151 855 S	
	20 3/4"	10 3/8"	19.05 x 1.6	F-80	16.0	151 866 V	151 856 T	
	20 3/4"	15 1/2"	19.05 x 1.6	F-80	16.0	151 867 W	151 857 U	
	25 1"	10 3/8"	25.40 x 1.6	F-80	16.0	146 764 H	147 052 U	
	25 1"	15 1/2"	25.40 x 1.6	F-80	16.0	146 792 W	147 080 V	
	25 1"	20 3/4"	25.40 x 1.6	F-80	16.0	146 816 N	147 106 Y	
	40 1 1/2"	20 3/4"	38.10 x 1.6	G-100	16.0	146 842 Y	147 132 R	
	40 1 1/2"	25 1"	38.10 x 1.6	G-100	16.0	146 868 A	147 157 S	
	40 1 1/2"	32 1 1/4"	38.10 x 1.6	G-100	16.0	146 896 P	147 188 S	
	50 2"	25 1"	50.80 x 1.6	H-125	16.0	146 882 R	147 171 Y	
	50 2"	32 1 1/4"	50.80 x 1.6	H-125	16.0	146 910 Y	147 202 G	
	50 2"	40 1 1/2"	50.80 x 1.6	H-125	16.0	146 922 Q	147 216 V	
	B	15 1/2"	8 1/4"	12.70 x 1.6	F-80	16.0	151 868 F	151 858 D
		15 1/2"	10 3/8"	12.70 x 1.6	F-80	16.0	151 869 G	151 859 E
		20 3/4"	8 1/4"	19.05 x 1.6	F-80	16.0	151 870 D	151 860 B
		20 3/4"	10 3/8"	19.05 x 1.6	F-80	16.0	151 871 S	151 861 Y
		20 3/4"	15 1/2"	19.05 x 1.6	F-80	16.0	151 872 T	151 862 Z
		25 1"	10 3/8"	25.40 x 1.6	F-80	16.0	146 771 G	147 059 B
25 1"		15 1/2"	25.40 x 1.6	F-80	16.0	146 799 D	147 087 Q	
25 1"		20 3/4"	25.40 x 1.6	F-80	16.0	146 823 M	147 113 N	
40 1 1/2"		20 3/4"	38.10 x 1.6	G-100	16.0	146 849 F	147 139 Y	
40 1 1/2"		25 1"	38.10 x 1.6	G-100	16.0	146 875 Z	147 164 Z	
40 1 1/2"		32 1 1/4"	38.10 x 1.6	G-100	16.0	146 903 W	147 195 R	
50 2"		25 1"	50.80 x 1.6	H-125	16.0	146 889 Y	147 178 F	
50 2"		32 1 1/4"	50.80 x 1.6	H-125	16.0	146 917 K	147 209 P	
50 2"		40 1 1/2"	50.80 x 1.6	H-125	16.0	146 929 X	147 223 U	



*seal system: SS/SS plug stainless steel / seat stainless steel
PTFE/SS plug PTFE / seat stainless steel

2/2-Way Globe Control Valve, Pneumatically Operated Cast Stainless Steel Body with Weld Ends

Valve Actuation System: TOP Control

Type: 8630

TOP Control Continuous type 8630 forms a mechanical and functional unit with the pneumatic actuator. Main functional groups of the TOP Control continuous are:

- Positioner and process controller in one device, integrated PID
- Position measuring system for continuous feedback of the actual position of the pneumatic actuator and the valve
- Microprocessor controlled electronics for signal processing, setpoint/process value comparison
- Pneumatic positioning system for single and double-acting actuators whose integrated pilot valves are driven by pulse-width modulation

TOP Control continuous can be used in a variety of different applications in fluid control solutions.



Continuous Globe valve

2712

Valve Actuation System: SIDE Control 3-wire

Type: 1067

SIDE Control type 1067 is a 3-wire process controller and positioner composed of the main functional groups position measuring system, electropneumatic actuator system and microprocessor electronics.

Main functional groups of the SIDE Control continuous are:

- Positioner and process controller in one device, integrated PID
- Position measuring system for continuous feedback of the actual position of the pneumatic actuator and the valve
- Microprocessor controlled electronics for signal processing, setpoint/process value comparison
- Pneumatic positioning system for single and double-acting actuators whose integrated pilot valves are driven by pulse-width modulation



Valve Actuation System: SIDE Control 2-wire

Type: 8635

SIDE Control S type 8635S is a 2-wire electropneumatic process controller and positioner for pneumatically operated process valves. The input signal of 4 - 20 mA serves to transmit the set point signal and to supply the device with power at the same time.

As an alternative, communication can be effected via the HART protocol.

- The HART protocol is modulated onto the current signal using the FSK procedure (Frequency Shift Keying)
- Signal processing, control and drive of the internal positioning system are carried out by microprocessor controlled electronics
- The software function autotune implemented enables automatic adaptation of the positioner to the control valve used
- Parametrization and operation are performed comfortably via three keys and a display with plain text, or via the HART protocol (optional)
- To build up a decentralized control system, SIDE Control is equipped with a process controller with PID behaviour. In this case, a process control loop is superimposed on the positioning loop in a cascade structure
- The compact, robust design, the housing is suitable for use in chemical and process engineering



2/2-Way Globe Control Valve, Pneumatically Operated Cast Stainless Steel Body with Weld Ends

Dimensions [mm]

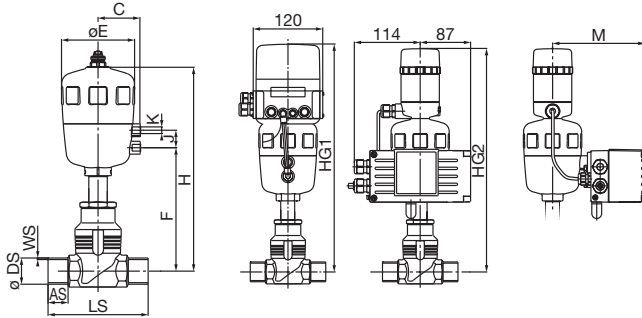

Port size	8630		1067		8635	
	HG ¹	HG ²	M	HG ²	M	
10	391	384	145	384	159	
15	391	384	145	384	159	
20	389	379	145	379	159	
25	389	382	145	382	159	
32	476	469	158	469	172	
40	481	474	158	474	172	
50	618	511	171	511	185	

All Actuators										ISO 4200		DIN 11850 S2		BS 4825		ASME BPE		
Port size	Act. size ϕ	C	E	F	H	K	J	HG	AS	LS	DS	WS	DS	WS	DS	WS	DS	WS
10	F-80	60	101	166	264	G 1/4	24	20	90	17.2	1.6	13.0	1.5	-	-	-	-	-
15	F-80	60	101	166	264	G 1/4	24	20	90	21.3	1.6	19.0	1.5	12.7	1.2	12.7	1.6	1.6
20	F-80	60	101	180	259	G 1/4	24	20	100	26.9	1.6	23.0	1.5	19.0	1.2	19.0	1.6	1.6
25	F-80	60	101	164	262	G 1/4	24	26	130	33.7	2.0	29.0	1.5	25.4	1.6	25.4	1.6	1.6
32	G-100	73	127	208	346	G 1/4	30	26	140	42.4	2.0	35.0	1.5	-	-	-	-	-
40	G-100	73	127	213	351	G 1/4	30	26	150	48.3	2.0	41.0	1.5	38.1	1.6	38.1	1.6	1.6
50	H-125	86	153	225	388	G 1/4	30	26	175	60.3	2.0	53.0	1.5	50.8	1.6	50.8	1.6	1.6

Further Process Connections are:

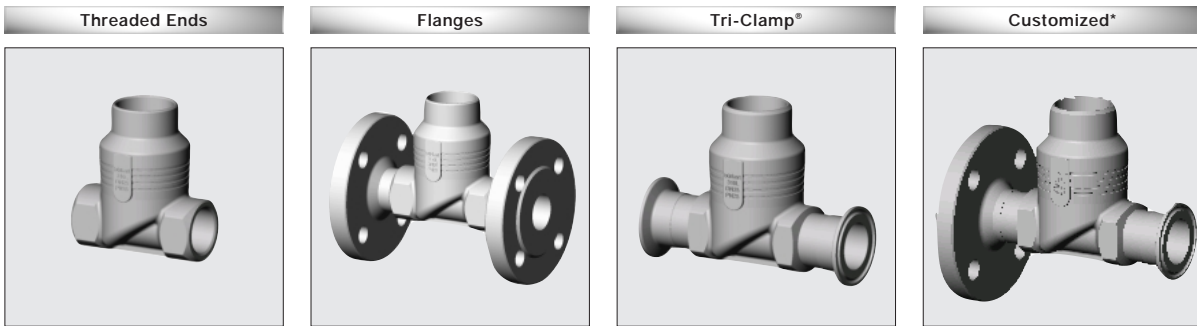

* e.g. one side with flange, other side Tri-Clamp®

Globe Valve Systems

A continuous globe valve system consists of a continuous globe valve type 2712 and a valve actuation system TOP Control type 8630 or SIDE Control type 1067 or 8635. Burkert offers a wide range of valve actuation systems suitable for the new continuous globe valve. Example for variations of continuous globe valve systems

	+		=			
Globe Valve		Valve Actuation		Complete Continuous Globe Valve Systems		
2712 Globe Valve with required process connection		Valve Actuation with all its needs TOP Control or SIDE Control		2712+8630 Globe Valve TOP Control system	2712+1067 Globe Valve SIDE Control system	2712+8635 Globe Valve SIDE Control system

In case of special application requirements, please consult for advice.

We reserve the right to make technical changes without notice.
908-GB/ 1-0192