

Paddle-Wheel Flow Sensor/Switch with Optical Principle for Easy ON/OFF Control



8039

BRASS, INLINE Quarter-Turn

- ✓ **ALL IN ONE:**
Indication, Monitoring, Transmitting and ON/OFF Control in One Device
- ✓ **Programmable Monitoring and ON/OFF Control System for Easy Fluid Control Systems**
- ✓ **Optical Measurement Principle:**
 - Insensitive to Magnetic Fields
 - Flow Sense Detection

This intelligent sensor/switch with an extra-large display is specifically designed to switch a valve and to establish a monitoring system or an ON/OFF control loop.

Switching points can be programmed with the 3 key pads and the connection to the process in the piping is done with standard fittings.

Process Specification

Pipe diameter	DN 8 up to DN 50
Measuring range	0.3 m/s up to 10 m/s
Switching accuracy	
Teach-in	±1% fs.
Standard K-factor	±1% fs., ±3% of measured value
Programming mode	Hysteresis or window
Repeatability	0.4%
Fitting	Bürkert INLINE fitting S039
Housing material	PC +20% glass fibre
Front panel foil	Polyester
Sensor element	Paddle-wheel without magnet
Wetted parts	PVDF, ceramic, FPM standard (EPDM option)

Electrical Specification

Voltage supply	12 up to 30 VDC
Reversed polarity of DC	Protected
Transistor output (programmable)	NPN and PNP open collector 5 up to 30 VDC, 700 mA
or	
Relay output (programmable)	3 A/250 V/AC, or 3 A/30 VDC
Current consumption	Max. 80 mA at 24 VDC (no-load)
Short circuit protection	Yes, for transistor output
Recommended max. length of supply cable	100 m shielded, cross section 0.14 – 0.5 mm ²

Electrical Connections

EaseOn	Cable plug 2511 (on request)
Cable plug	Cable plug 2508, DIN 43650A
Multipin	5 pins, M12

Environment Specifications

Fluid temperature	Max. 100°C
Ambient temperature range	0 up to +60°C
Fluid pressure max.	PN 10 at +20°C
Protection class	IP 65 with connector plugged-in

Standards

EMC	EN 50081-1, 50082-2, 61010-1
Vibration resistance	EN 60068-2-6, 10 g, 10 – 200 Hz
Shock resistance	EN 60068-2-27, 50 g, 11 ms, 1/2 sinus

PRELIMINARY
14.11.2001
Index 02

Applications: • Monitoring of cooling circuits for power supplies

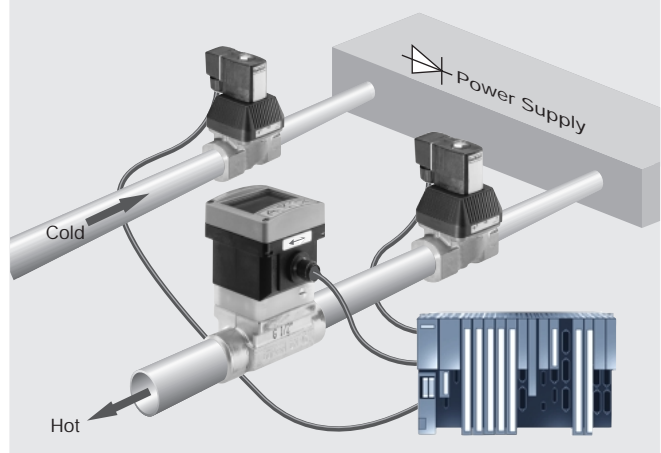

Pressure-Temperature-Diagram

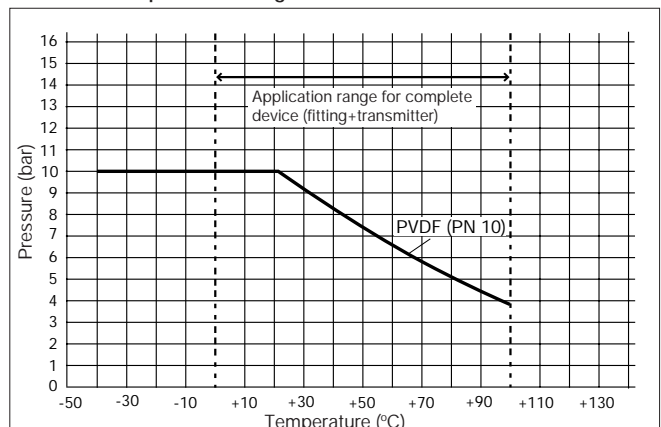

Paddle-Wheel Flow Sensor/Switch with Optical Principle for Easy ON/OFF Control

SE39 Display and Electronic for INLINE fitting S039 (SE39 + S039 form the Sensor/Switch 8039)

Voltage supply	Output	Connector	Item-No. (Standard)	Item-No. (NAFTA)
12 – 30 V/DC	NPN	Cable plug 2508 (DIN 43 650)	440 378 Z	440 380 Q
12 – 30 V/DC	PNP	Cable plug 2508 (DIN 43 650)	440 379 S	440 381 D
12 – 30 V/DC	NPN and PNP	M12 plug, 5 pins	440 377 Q	–
12 – 30 V/DC	Relay	M12 plug and cable plug 2508 (DIN 43 650)	440 382 E	440 383 F

Accessories for ON/OFF Flow Control System 8039

Description	Item-No.
M12 5 pins female cable connector with plastic threaded locking ring	917 116 D
M12 5 pins female connector moulded on cable (2 m., shielded)	438 680 F

Has to be ordered separately

Fittings S039 - Brass, INLINE Quarter-Turn

Specification	Item-No. / Orifice						
	DN 8 ¹⁾	DN 15	DN 20	DN 25	DN 32	DN 40	DN 50
G-port connection (internal thread)	444 670 J	440 645 M	440 646 N	440 647 P	440 648 Y	440 649 Z	440 650 W
NPT-port connection (internal thread)	444 671 F	444 672 Q	444 673 H	444 674 A	444 675 B	444 676 C	444 677 D

¹⁾ Only version with G/NPT external thread 1/2"

Has to be ordered separately

Dimensions [mm]

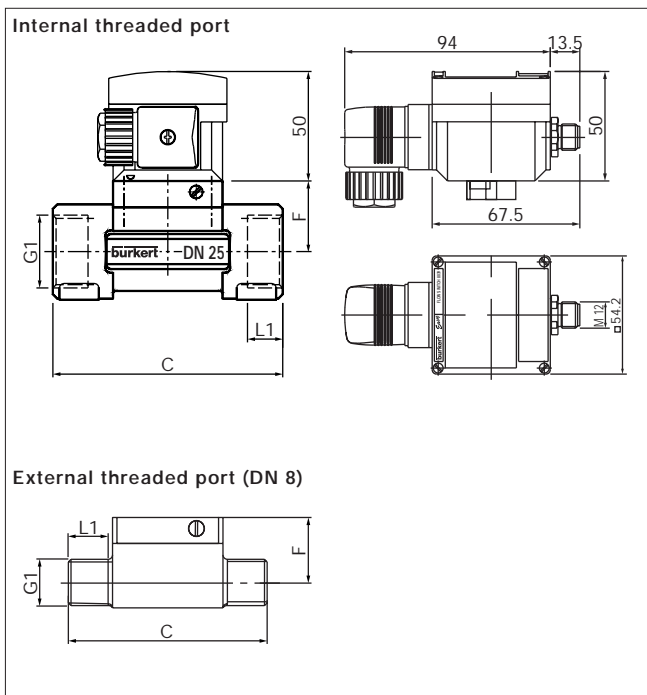

Electrical connections

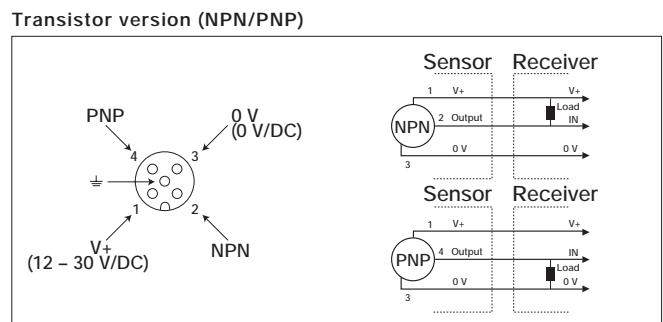

Relay version

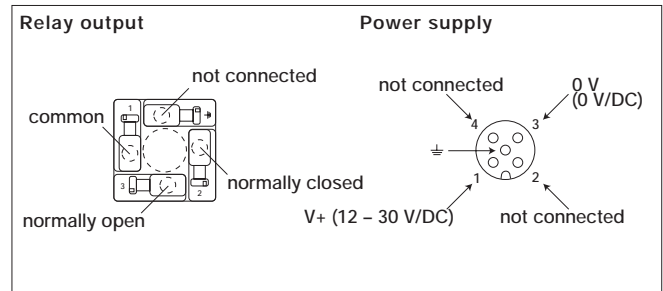

Variable dimensions

DN [mm]	C [mm]	F [mm]	G1 [inch]	[inch]	L1 [mm]
8	90	29.7	G 1/2	NPT 1/2	14.0
15	84	34.5	G 1/2	NPT 1/2	16.0
20	94	32.0	G 3/4	NPT 3/4	17.0
25	104	32.2	G 1	NPT 1	23.5
32	119	35.8	G 1 1/4	NPT 1 1/4	23.5
40	129	39.6	G 1 1/2	NPT 1 1/2	23.5
50	149	45.7	G 2	NPT 2	27.5

NPN or PNP version

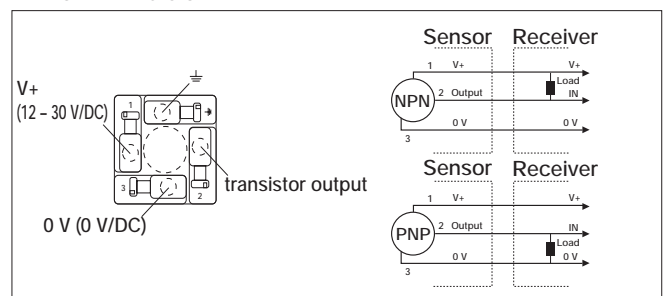

In case of special application requirements, please consult for advice.

We reserve the right to make technical changes without notice. 107-GB/ 1-0248